



MINNESOTA DEPT OF TRANSPORTATION

TRAFFIC DATA COLLECTION - METRO

I-35 AT CSAH-50, WEST RAMPS
 REF.PT.: 085.507
 JAMAR #D4-3358 CE
 TURN MOVEMENT COUNT

File Name : i-35 at csah-50 west ramp 2007
 Site Code : 00000000
 Start Date : 2/15/2007
 Page No : 1

Groups Printed- Cars & Trucks

Start Time	RAMP FROM I-35 SB Southbound				CSAH-50 Westbound				RAMP TO I-35 SB Northbound				CSAH-50 Eastbound				Int. Total
	Left	Thru	Right	Peds	Left	Thru	Right	Peds	Left	Thru	Right	Peds	Left	Thru	Right	Peds	
06:00	30	0	7	0	9	28	0	0	0	0	0	0	0	29	20	0	123
06:15	35	0	11	0	4	51	0	0	0	0	0	0	0	39	33	0	173
06:30	51	0	12	0	10	70	0	0	0	0	0	0	0	33	21	0	197
06:45	67	0	20	0	14	59	0	0	0	0	0	0	0	46	23	0	229
Total	183	0	50	0	37	208	0	0	0	0	0	0	0	147	97	0	722
07:00	46	0	12	0	7	71	0	0	0	0	0	0	0	60	42	0	238
07:15	65	0	10	0	12	112	0	0	0	0	0	0	0	69	38	0	306
07:30	55	0	6	0	18	133	0	0	0	0	0	0	0	50	29	0	291
07:45	37	0	12	0	8	71	0	0	0	0	0	0	0	53	21	0	202
Total	203	0	40	0	45	387	0	0	0	0	0	0	0	232	130	0	1037
08:00	53	0	5	0	11	77	0	0	0	0	0	0	0	58	31	0	235
08:15	59	0	15	0	22	81	0	0	0	0	0	0	0	63	21	0	261
08:30	63	0	16	0	13	75	0	0	0	0	0	0	0	65	16	0	248
08:45	54	0	16	0	17	77	0	0	0	0	0	0	0	60	12	0	236
Total	229	0	52	0	63	310	0	0	0	0	0	0	0	246	80	0	980
*** BREAK ***																	
11:00	76	0	21	0	23	61	0	0	0	0	0	0	0	68	26	0	275
11:15	86	0	22	0	22	55	0	0	0	0	0	0	0	77	29	0	291
11:30	96	0	26	0	26	66	0	0	0	0	0	0	0	70	25	0	309
11:45	102	0	24	0	20	62	0	0	0	0	0	0	0	55	22	0	285
Total	360	0	93	0	91	244	0	0	0	0	0	0	0	270	102	0	1160
12:00	81	0	17	0	18	50	0	0	0	0	0	0	0	49	22	0	237
12:15	84	0	17	0	37	92	0	0	0	0	0	0	0	82	39	0	351
12:30	101	0	20	0	22	74	0	0	0	0	0	0	0	81	25	0	323
12:45	99	0	20	0	31	55	0	0	0	0	0	0	0	65	31	0	301
Total	365	0	74	0	108	271	0	0	0	0	0	0	0	277	117	0	1212
*** BREAK ***																	
15:00	156	0	28	0	34	79	0	0	0	0	0	0	0	88	44	0	429
15:15	175	0	28	0	32	88	0	0	0	0	0	0	0	97	38	0	458
15:30	166	0	20	0	46	102	0	0	0	0	0	0	0	81	56	0	471
15:45	188	0	32	0	46	100	0	0	0	0	0	0	0	98	50	0	514
Total	685	0	108	0	158	369	0	0	0	0	0	0	0	364	188	0	1872
16:00	170	0	23	0	48	60	0	0	0	0	0	0	0	61	48	0	410
16:15	219	0	37	0	46	74	0	0	0	0	0	0	0	83	60	0	519
16:30	243	0	34	0	74	106	0	0	0	0	0	0	0	90	53	0	600
16:45	256	0	40	0	53	101	0	0	0	0	0	0	2	127	66	0	645
Total	888	0	134	0	221	341	0	0	0	0	0	0	2	361	227	0	2174
17:00	249	0	31	0	43	116	0	0	0	0	0	0	0	98	78	0	615
17:15	254	0	37	0	62	100	0	0	0	0	0	0	0	109	55	0	617
17:30	231	0	36	0	45	91	0	0	0	0	0	0	1	109	68	0	581
17:45	184	0	34	0	53	90	0	0	0	0	0	0	1	87	39	0	488
Total	918	0	138	0	203	397	0	0	0	0	0	0	2	403	240	0	2301
Grand Total	3831	0	689	0	926	2527	0	0	0	0	0	0	4	2300	1181	0	11458
Apprch %	84.8	0	15.2	0	26.8	73.2	0	0	0	0	0	0	0.1	66	33.9	0	
Total %	33.4	0	6	0	8.1	22.1	0	0	0	0	0	0	0	20.1	10.3	0	



MINNESOTA DEPT OF TRANSPORTATION

TRAFFIC DATA COLLECTION - METRO

I-35 AT CSAH-50, WEST RAMPS
 REF.PT.: 085.507
 JAMAR #D4-3358 CE
 TURN MOVEMENT COUNT

File Name : i-35 at csah-50 west ramp 2007
 Site Code : 00000000
 Start Date : 2/15/2007
 Page No : 2

Start Time	RAMP FROM I-35 SB Southbound					CSAH-50 Westbound					RAMP TO I-35 SB Northbound					CSAH-50 Eastbound					Int. Total
	Left	Thru	Right	Peds	App. Total	Left	Thru	Right	Peds	App. Total	Left	Thru	Right	Peds	App. Total	Left	Thru	Right	Peds	App. Total	
Peak Hour Analysis From 06:00 to 08:45 - Peak 1 of 1																					
Peak Hour for Entire Intersection Begins at 06:45																					
06:45	67	0	20	0	87	14	59	0	0	73	0	0	0	0	0	0	46	23	0	69	229
07:00	46	0	12	0	58	7	71	0	0	78	0	0	0	0	0	0	60	42	0	102	238
07:15	65	0	10	0	75	12	112	0	0	124	0	0	0	0	0	0	69	38	0	107	306
07:30	55	0	6	0	61	18	133	0	0	151	0	0	0	0	0	0	50	29	0	79	291
Total Volume	233	0	48	0	281	51	375	0	0	426	0	0	0	0	0	0	225	132	0	357	1064
% App. Total																					
PHF	.869	.000	.600	.000	.807	.708	.705	.000	.000	.705	.000	.000	.000	.000	.000	.000	.815	.786	.000	.834	.869

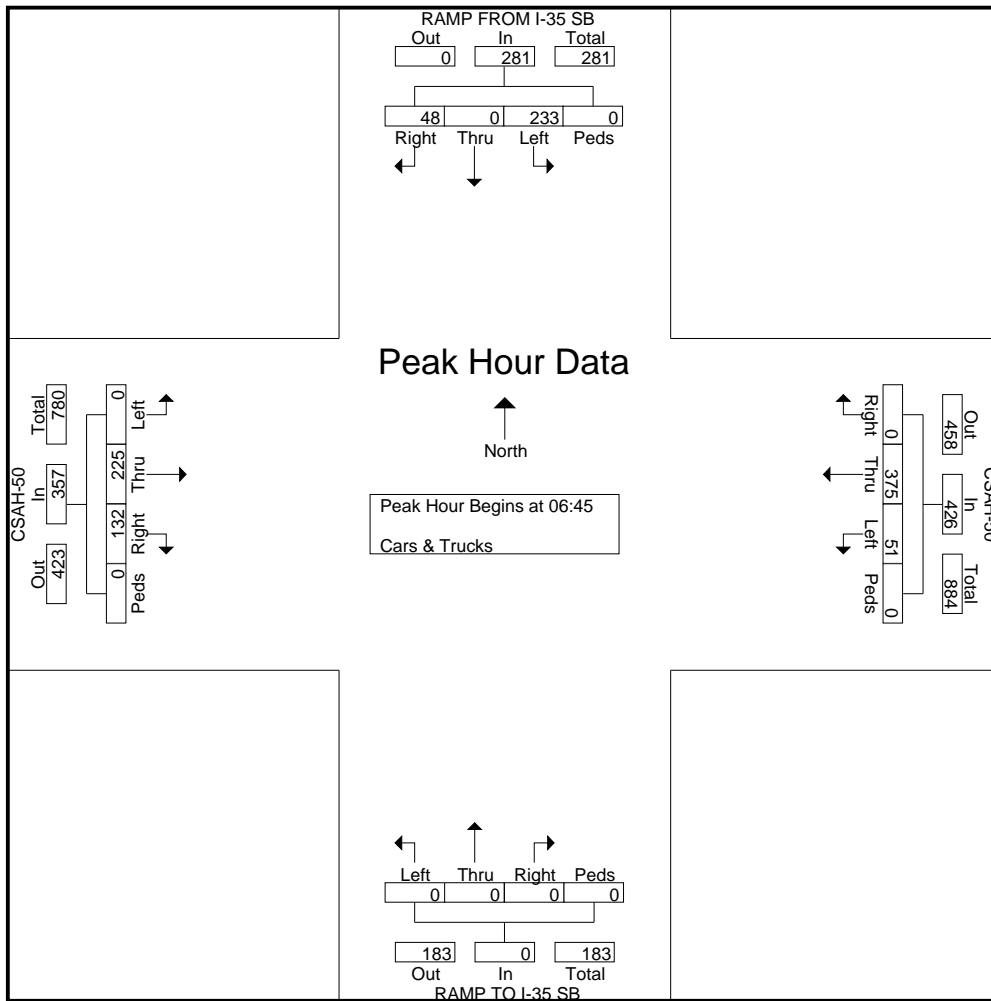



MINNESOTA DEPT OF TRANSPORTATION

TRAFFIC DATA COLLECTION - METRO

I-35 AT CSAH-50, WEST RAMPS
 REF.PT.: 085.507
 JAMAR #D4-3358 CE
 TURN MOVEMENT COUNT

File Name : i-35 at csah-50 west ramp 2007
 Site Code : 00000000
 Start Date : 2/15/2007
 Page No : 3

Start Time	RAMP FROM I-35 SB Southbound					CSAH-50 Westbound					RAMP TO I-35 SB Northbound					CSAH-50 Eastbound					Int. Total
	Left	Thru	Right	Peds	App. Total	Left	Thru	Right	Peds	App. Total	Left	Thru	Right	Peds	App. Total	Left	Thru	Right	Peds	App. Total	
Peak Hour Analysis From 15:00 to 17:45 - Peak 1 of 1																					
Peak Hour for Entire Intersection Begins at 16:30																					
16:30	243	0	34	0	277	74	106	0	0	180	0	0	0	0	0	0	90	53	0	143	600
16:45	256	0	40	0	296	53	101	0	0	154	0	0	0	0	0	2	127	66	0	195	645
17:00	249	0	31	0	280	43	116	0	0	159	0	0	0	0	0	0	98	78	0	176	615
17:15	254	0	37	0	291	62	100	0	0	162	0	0	0	0	0	0	109	55	0	164	617
Total Volume	1002	0	142	0	1144	232	423	0	0	655	0	0	0	0	0	2	424	252	0	678	2477
% App. Total	87.6	0	12.4	0		35.4	64.6	0	0		0	0	0	0		0.3	62.5	37.2	0		
PHF	.979	.000	.888	.000	.966	.784	.912	.000	.000	.910	.000	.000	.000	.000	.000	.250	.835	.808	.000	.869	.960

