



MINNESOTA DEPT OF TRANSPORTATION
TRAFFIC DATA COLLECTION - METRO

I-35 AT TH-97, EAST RAMPS
REF.PT.: 129.388
JAMAR # 631 RE
TURN MOVEMENT COUNT

File Name : I-35 AT TH-97 EAST RAMPS 2006
Site Code : 00000000
Start Date : 10/18/2006
Page No : 1

Groups Printed- Cars & Trucks

Start Time	RAMP TO I-35 NB Southbound				TH-97 Westbound				RAMP FROM I-35E NB Northbound				TH-97 Eastbound				Int. Total
	Left	Thru	Right	Peds	Left	Thru	Right	Peds	Left	Thru	Right	Peds	Left	Thru	Right	Peds	
06:00	0	0	0	0	0	251	2	0	13	0	20	0	9	30	0	0	325
06:15	0	0	0	0	0	267	8	0	10	0	39	0	7	43	0	0	374
06:30	0	0	0	0	0	255	4	0	11	0	45	0	8	36	0	0	359
06:45	0	0	0	0	0	258	17	0	9	2	61	0	6	30	0	0	383
Total	0	0	0	0	0	1031	31	0	43	2	165	0	30	139	0	0	1441
07:00	0	0	0	0	0	263	10	0	16	4	46	0	9	55	0	0	403
07:15	0	0	0	0	0	212	6	0	10	0	79	0	29	79	0	0	415
07:30	0	0	0	0	0	210	14	0	12	0	62	0	18	76	0	0	392
07:45	0	0	0	0	0	243	15	0	16	3	74	0	18	88	0	0	457
Total	0	0	0	0	0	928	45	0	54	7	261	0	74	298	0	0	1667
08:00	0	0	0	0	0	214	7	0	14	0	59	0	14	41	0	0	349
08:15	0	0	0	0	0	206	15	0	7	0	48	0	16	37	0	0	329
08:30	0	0	0	0	0	171	4	0	9	0	47	0	20	35	0	0	286
08:45	0	0	0	0	0	159	12	0	8	2	55	0	15	33	0	0	284
Total	0	0	0	0	0	750	38	0	38	2	209	0	65	146	0	0	1248
*** BREAK ***																	
15:00	0	0	0	0	0	114	17	0	38	0	127	0	35	38	0	0	369
15:15	0	0	0	0	0	98	34	0	42	0	131	0	46	54	0	0	405
15:30	0	0	0	0	0	105	26	0	41	0	182	0	48	63	0	0	465
15:45	0	0	0	0	0	126	36	0	41	0	193	0	58	77	0	0	531
Total	0	0	0	0	0	443	113	0	162	0	633	0	187	232	0	0	1770
16:00	0	0	0	0	0	113	28	0	44	1	217	0	56	74	0	0	533
16:15	0	0	0	0	0	113	26	0	40	0	203	0	57	84	0	0	523
16:30	0	0	0	0	0	124	27	0	41	1	224	0	55	92	0	0	564
16:45	0	0	0	0	0	131	43	0	40	1	243	0	63	70	0	0	591
Total	0	0	0	0	0	481	124	0	165	3	887	0	231	320	0	0	2211
17:00	0	0	0	0	0	141	33	0	39	0	220	0	51	92	0	0	576
17:15	0	0	0	0	0	153	33	0	39	0	204	0	39	81	0	0	549
17:30	0	0	0	0	0	129	29	0	47	2	218	0	71	71	0	0	567
17:45	0	0	0	0	0	102	33	0	42	0	215	0	71	68	0	0	531
Total	0	0	0	0	0	525	128	0	167	2	857	0	232	312	0	0	2223
Grand Total	0	0	0	0	0	4158	479	0	629	16	3012	0	819	1447	0	0	10560
Apprch %	0	0	0	0	0	89.7	10.3	0	17.2	0.4	82.4	0	36.1	63.9	0	0	
Total %	0	0	0	0	0	39.4	4.5	0	6	0.2	28.5	0	7.8	13.7	0	0	



MINNESOTA DEPT OF TRANSPORTATION

TRAFFIC DATA COLLECTION - METRO

I-35 AT TH-97, EAST RAMPS
 REF.PT.: 129.388
 JAMAR # 631 RE
 TURN MOVEMENT COUNT

File Name : I-35 AT TH-97 EAST RAMPS 2006
 Site Code : 00000000
 Start Date : 10/18/2006
 Page No : 2

Start Time	RAMP TO I-35 NB Southbound					TH-97 Westbound					RAMP FROM I-35E NB Northbound					TH-97 Eastbound					Int. Total
	Left	Thru	Right	Peds	App. Total	Left	Thru	Right	Peds	App. Total	Left	Thru	Right	Peds	App. Total	Left	Thru	Right	Peds	App. Total	
Peak Hour Analysis From 06:00 to 08:45 - Peak 1 of 1																					
Peak Hour for Entire Intersection Begins at 07:00																					
07:00	0	0	0	0	0	0	263	10	0	273	16	4	46	0	66	9	55	0	0	64	403
07:15	0	0	0	0	0	0	212	6	0	218	10	0	79	0	89	29	79	0	0	108	415
07:30	0	0	0	0	0	0	210	14	0	224	12	0	62	0	74	18	76	0	0	94	392
07:45	0	0	0	0	0	0	243	15	0	258	16	3	74	0	93	18	88	0	0	106	457
Total Volume	0	0	0	0	0	0	928	45	0	973	54	7	261	0	322	74	298	0	0	372	1667
% App. Total	0	0	0	0	0	0	95.4	4.6	0		16.8	2.2	81.1	0		19.9	80.1	0	0		
PHF	.000	.000	.000	.000	.000	.000	.882	.750	.000	.891	.844	.438	.826	.000	.866	.638	.847	.000	.000	.861	.912

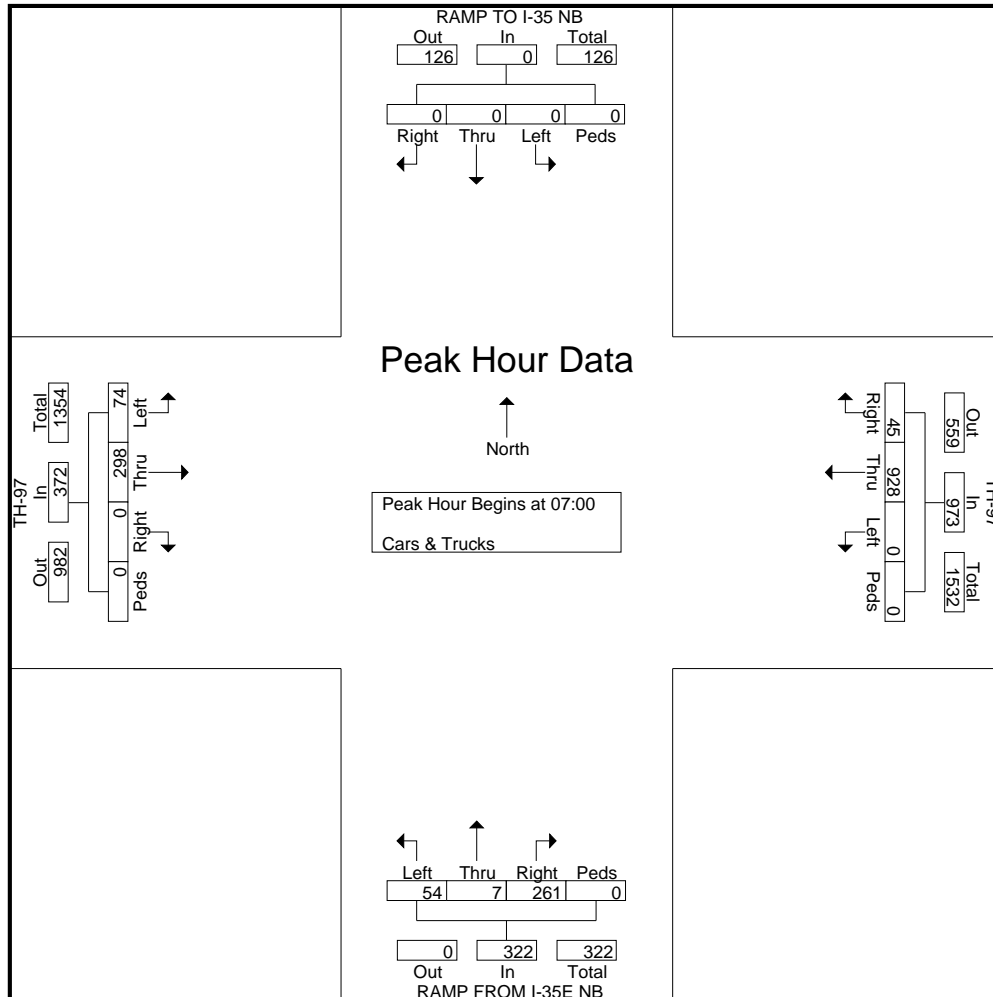



MINNESOTA DEPT OF TRANSPORTATION

TRAFFIC DATA COLLECTION - METRO

I-35 AT TH-97, EAST RAMPS
 REF.PT.: 129.388
 JAMAR # 631 RE
 TURN MOVEMENT COUNT

File Name : I-35 AT TH-97 EAST RAMPS 2006
 Site Code : 00000000
 Start Date : 10/18/2006
 Page No : 3

Start Time	RAMP TO I-35 NB Southbound					TH-97 Westbound					RAMP FROM I-35E NB Northbound					TH-97 Eastbound					Int. Total
	Left	Thru	Right	Peds	App. Total	Left	Thru	Right	Peds	App. Total	Left	Thru	Right	Peds	App. Total	Left	Thru	Right	Peds	App. Total	
Peak Hour Analysis From 15:00 to 17:45 - Peak 1 of 1																					
Peak Hour for Entire Intersection Begins at 16:45																					
16:45	0	0	0	0	0	0	131	43	0	174	40	1	243	0	284	63	70	0	0	133	591
17:00	0	0	0	0	0	0	141	33	0	174	39	0	220	0	259	51	92	0	0	143	576
17:15	0	0	0	0	0	0	153	33	0	186	39	0	204	0	243	39	81	0	0	120	549
17:30	0	0	0	0	0	0	129	29	0	158	47	2	218	0	267	71	71	0	0	142	567
Total Volume	0	0	0	0	0	0	554	138	0	692	165	3	885	0	1053	224	314	0	0	538	2283
% App. Total	0	0	0	0	0	0	80.1	19.9	0		15.7	0.3	84	0		41.6	58.4	0	0		
PHF	.000	.000	.000	.000	.000	.000	.905	.802	.000	.930	.878	.375	.910	.000	.927	.789	.853	.000	.000	.941	.966

