

SEH CONSULTING
Traffic Data Collection
TURN MOVEMENT COUNT

Burnsville Parkway at Pillsbury Avenue
6/28/2007 (AM,MID) and 7/10/2007 (PM)
data by SEH
TURN MOVEMENT COUNT

File Name : Burnsville Pkwy at Pillsbury Ave 2007
Site Code : 00000004
Start Date : 6/28/2007
Page No : 1

Groups Printed- Unshifted - Heavy Veh - -Turns

Start Time	Pillsbury Ave Southbound				Burnsville Pkwy Westbound				commercial entrance Northbound				Burnsville Pkwy Eastbound				Exclu. Total	Inclu. Total	Int. Total
	Left	Thru	Right	Peds	Left	Thru	Right	Peds	Left	Thru	Right	Peds	Left	Thru	Right	Peds			
06:00	1	0	2	0	1	44	2	0	1	2	0	0	4	42	0	0	0	99	99
06:15	1	0	3	0	0	60	5	0	2	1	0	0	11	74	0	0	0	157	157
06:30	0	0	1	0	1	73	2	0	0	0	0	0	1	94	1	0	0	173	173
06:45	0	0	1	0	1	81	16	0	0	0	0	0	21	137	0	0	0	257	257
Total	2	0	7	0	3	258	25	0	3	3	0	0	37	347	1	0	0	686	686
07:00	1	0	3	0	3	94	6	0	0	0	0	0	4	129	0	0	0	240	240
07:15	1	0	2	0	2	85	10	0	0	0	0	0	11	165	3	0	0	279	279
07:30	1	0	4	0	4	124	10	0	0	0	2	0	6	206	0	0	0	357	357
07:45	3	0	6	0	13	139	9	0	0	0	0	0	15	197	5	0	0	387	387
Total	6	0	15	0	22	442	35	0	0	0	2	0	36	697	8	0	0	1263	1263
08:00	5	0	7	0	10	112	8	0	2	0	1	0	14	134	2	0	0	295	295
08:15	3	0	4	0	10	105	12	0	0	0	2	0	12	113	6	0	0	267	267
08:30	7	0	1	0	14	115	15	1	1	2	0	0	13	108	2	0	1	278	279
08:45	5	0	7	0	5	113	20	0	0	0	1	0	23	210	3	0	0	387	387
Total	20	0	19	0	39	445	55	1	3	2	4	0	62	565	13	0	1	1227	1228
*** BREAK ***																			
11:00	4	0	6	0	16	113	17	0	1	2	3	0	11	117	2	0	0	292	292
11:15	6	0	9	0	15	96	13	0	6	1	4	0	20	130	2	0	0	302	302
11:30	3	0	11	1	12	107	16	0	4	0	6	0	25	141	1	0	1	326	327
11:45	14	1	6	0	10	147	15	0	2	0	4	0	22	134	3	0	0	358	358
Total	27	1	32	1	53	463	61	0	13	3	17	0	78	522	8	0	1	1278	1279
12:00	12	1	13	0	8	125	18	0	5	2	12	0	15	134	1	0	0	346	346
12:15	14	0	11	0	11	131	22	0	2	0	1	0	15	144	1	0	0	352	352
12:30	10	0	29	0	14	121	13	0	2	0	6	0	15	156	3	0	0	369	369
12:45	14	0	20	0	9	125	9	0	3	1	6	0	11	162	4	0	0	364	364
Total	50	1	73	0	42	502	62	0	12	3	25	0	56	596	9	0	0	1431	1431
*** BREAK ***																			
15:15	10	0	10	0	7	155	10	0	4	0	2	0	15	167	6	0	0	386	386
15:30	4	0	8	0	13	155	15	0	1	0	4	0	13	167	0	0	0	380	380
15:45	7	1	8	0	5	165	13	0	2	0	0	0	11	194	2	0	0	408	408
Total	21	1	26	0	25	475	38	0	7	0	6	0	39	528	8	0	0	1174	1174
16:00	8	0	12	0	11	161	16	1	1	2	5	0	8	169	2	0	1	395	396
16:15	5	1	8	0	6	173	9	0	2	1	7	0	13	190	3	0	0	418	418
16:30	11	1	12	0	9	165	12	0	5	0	4	0	20	199	1	0	0	439	439
16:45	4	1	15	0	10	184	10	0	6	0	3	0	10	203	3	0	0	449	449
Total	28	3	47	0	36	683	47	1	14	3	19	0	51	761	9	0	1	1701	1702
17:00	7	0	12	0	7	217	16	0	5	0	10	0	13	218	2	0	0	507	507
17:15	2	0	12	0	16	204	14	0	2	0	3	0	15	241	3	0	0	512	512
17:30	6	0	22	0	6	200	15	0	0	0	2	0	13	209	2	0	0	475	475
17:45	14	1	15	0	4	200	18	0	5	0	1	0	16	227	1	0	0	502	502
Total	29	1	61	0	33	821	63	0	12	0	16	0	57	895	8	0	0	1996	1996
18:00	9	0	16	0	7	170	15	0	0	0	2	0	13	181	3	0	0	416	416
Grand Total	192	7	296	1	260	4259	401	2	64	14	91	0	429	5092	67	0	3	11172	11175
Apprch %	38.8	1.4	59.8		5.3	86.6	8.2		37.9	8.3	53.8		7.7	91.1	1.2				
Total %	1.7	0.1	2.6		2.3	38.1	3.6		0.6	0.1	0.8		3.8	45.6	0.6		0	100	
Unshifted	191	7	296		233	4251	400		63	14	91		424	5086	67		0	0	11126
% Unshifted	99.5	100	100	100	89.6	99.8	99.8	100	98.4	100	100	0	98.8	99.9	100	0	0	0	99.6
Heavy Veh	1	0	0		0	8	1		1	0	0		0	6	0		0	0	17
% Heavy Veh	0.5	0	0	0	0	0.2	0.2	0	1.6	0	0	0	0	0.1	0	0	0	0	0.2
U--Turns	0	0	0		27	0	0		0	0	0		5	0	0		0	0	32
% U--Turns	0	0	0	0	10.4	0	0	0	0	0	0	0	1.2	0	0	0	0	0	0.3

SEH CONSULTING
Traffic Data Collection
TURN MOVEMENT COUNT

Burnsville Parkway at Pillsbury Avenue
6/28/2007 (AM,MID) and 7/10/2007 (PM)
data by SEH
TURN MOVEMENT COUNT

File Name : Burnsville Pkwy at Pillsbury Ave 2007
Site Code : 00000004
Start Date : 6/28/2007
Page No : 2

Start Time	Pillsbury Ave Southbound				Burnsville Pkwy Westbound				commercial entrance Northbound				Burnsville Pkwy Eastbound				Int. Total
	Left	Thru	Right	App. Total	Left	Thru	Right	App. Total	Left	Thru	Right	App. Total	Left	Thru	Right	App. Total	
Peak Hour Analysis From 06:00 to 08:45 - Peak 1 of 1																	
Peak Hour for Entire Intersection Begins at 07:15																	
07:15	1	0	2	3	2	85	10	97	0	0	0	0	11	165	3	179	279
07:30	1	0	4	5	4	124	10	138	0	0	2	2	6	206	0	212	357
07:45	3	0	6	9	13	139	9	161	0	0	0	0	15	197	5	217	387
08:00	5	0	7	12	10	112	8	130	2	0	1	3	14	134	2	150	295
Total Volume	10	0	19	29	29	460	37	526	2	0	3	5	46	702	10	758	1318
% App. Total	34.5	0	65.5		5.5	87.5	7		40	0	60		6.1	92.6	1.3		
PHF	.500	.000	.679	.604	.558	.827	.925	.817	.250	.000	.375	.417	.767	.852	.500	.873	.851

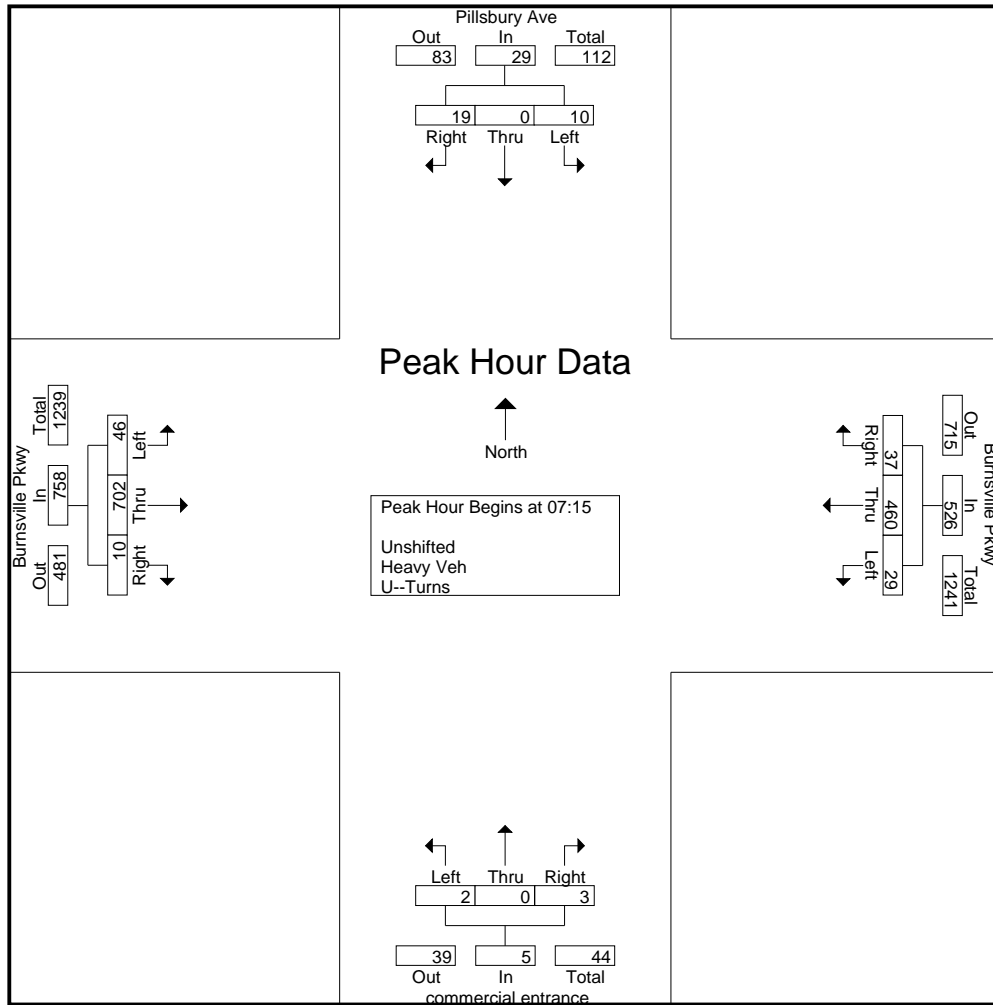

SEH CONSULTING
Traffic Data Collection
TURN MOVEMENT COUNT

Burnsville Parkway at Pillsbury Avenue
6/28/2007 (AM,MID) and 7/10/2007 (PM)
data by SEH
TURN MOVEMENT COUNT

File Name : Burnsville Pkwy at Pillsbury Ave 2007
Site Code : 00000004
Start Date : 6/28/2007
Page No : 3

Start Time	Pillsbury Ave Southbound				Burnsville Pkwy Westbound				commercial entrance Northbound				Burnsville Pkwy Eastbound				Int. Total
	Left	Thru	Right	App. Total	Left	Thru	Right	App. Total	Left	Thru	Right	App. Total	Left	Thru	Right	App. Total	
Peak Hour Analysis From 15:00 to 18:00 - Peak 1 of 1																	
Peak Hour for Entire Intersection Begins at 17:00																	
17:00	7	0	12	19	7	217	16	240	5	0	10	15	13	218	2	233	507
17:15	2	0	12	14	16	204	14	234	2	0	3	5	15	241	3	259	512
17:30	6	0	22	28	6	200	15	221	0	0	2	2	13	209	2	224	475
17:45	14	1	15	30	4	200	18	222	5	0	1	6	16	227	1	244	502
Total Volume	29	1	61	91	33	821	63	917	12	0	16	28	57	895	8	960	1996
% App. Total	31.9	1.1	67		3.6	89.5	6.9		42.9	0	57.1		5.9	93.2	0.8		
PHF	.518	.250	.693	.758	.516	.946	.875	.955	.600	.000	.400	.467	.891	.928	.667	.927	.975

