

# Albeck Gerken, Inc

Transportation Engineers

Traffic Data Collection

Plymouth Rd at Cartway Lane  
 Ref.Pt.: Minnetonka  
 Data by: Albeck Gerken Inc  
 TURN MOVEMENT COUNT

File Name : Plymouth Rd at Cartway Ln 2007  
 Site Code : 01827121  
 Start Date : 4/12/2007  
 Page No : 1

**Groups Printed- Unshifted**

Start Time	Plymouth Rd Southbound				Ridgedale entrance Westbound				Plymouth Rd Northbound				Cartway Lane Eastbound				Int. Total
	Left	Thru	Right	Peds	Left	Thru	Right	Peds	Left	Thru	Right	Peds	Left	Thru	Right	Peds	
06:00	4	20	3	0	0	1	1	0	2	15	1	0	10	0	1	0	58
06:15	1	18	2	0	2	0	1	0	0	14	0	0	16	2	1	0	57
06:30	12	28	4	0	0	0	1	0	2	41	0	0	24	0	0	0	112
06:45	8	46	10	0	2	1	2	0	2	55	3	0	22	3	1	1	156
<b>Total</b>	<b>25</b>	<b>112</b>	<b>19</b>	<b>0</b>	<b>4</b>	<b>2</b>	<b>5</b>	<b>0</b>	<b>6</b>	<b>125</b>	<b>4</b>	<b>0</b>	<b>72</b>	<b>5</b>	<b>3</b>	<b>1</b>	<b>383</b>
07:00	15	48	10	0	1	2	5	0	1	56	3	0	36	4	0	0	181
07:15	8	63	9	0	2	0	6	0	3	63	0	1	21	2	3	0	181
07:30	19	62	7	0	4	1	7	0	4	81	1	0	46	3	0	0	235
07:45	19	78	6	0	3	3	10	0	2	88	2	0	46	2	2	0	261
<b>Total</b>	<b>61</b>	<b>251</b>	<b>32</b>	<b>0</b>	<b>10</b>	<b>6</b>	<b>28</b>	<b>0</b>	<b>10</b>	<b>288</b>	<b>6</b>	<b>1</b>	<b>149</b>	<b>11</b>	<b>5</b>	<b>0</b>	<b>858</b>
08:00	14	89	6	0	1	0	9	0	4	70	1	0	43	3	3	0	243
08:15	16	96	14	0	0	2	11	0	3	76	0	0	38	6	5	0	267
08:30	23	93	14	0	2	4	13	0	6	65	0	0	45	3	2	0	270
08:45	33	87	15	0	1	8	16	0	3	78	3	0	64	10	3	0	321
<b>Total</b>	<b>86</b>	<b>365</b>	<b>49</b>	<b>0</b>	<b>4</b>	<b>14</b>	<b>49</b>	<b>0</b>	<b>16</b>	<b>289</b>	<b>4</b>	<b>0</b>	<b>190</b>	<b>22</b>	<b>13</b>	<b>0</b>	<b>1101</b>
*** BREAK ***																	
11:00	57	73	40	0	5	21	56	0	7	76	13	0	98	22	7	0	475
11:15	97	89	36	0	5	17	63	0	35	90	17	0	115	32	1	0	597
11:30	94	77	36	0	9	17	72	0	10	112	21	0	123	35	2	0	608
11:45	105	92	59	0	13	19	88	0	13	106	13	0	122	38	6	0	674
<b>Total</b>	<b>353</b>	<b>331</b>	<b>171</b>	<b>0</b>	<b>32</b>	<b>74</b>	<b>279</b>	<b>0</b>	<b>65</b>	<b>384</b>	<b>64</b>	<b>0</b>	<b>458</b>	<b>127</b>	<b>16</b>	<b>0</b>	<b>2354</b>
12:00	83	80	49	0	7	24	91	2	12	127	13	3	129	28	5	0	653
12:15	73	93	51	0	10	29	102	0	23	110	11	0	150	60	10	0	722
12:30	69	95	37	0	4	24	114	0	14	128	8	1	169	31	5	2	701
12:45	75	74	32	0	19	29	153	0	11	126	9	1	191	19	8	0	747
<b>Total</b>	<b>300</b>	<b>342</b>	<b>169</b>	<b>0</b>	<b>40</b>	<b>106</b>	<b>460</b>	<b>2</b>	<b>60</b>	<b>491</b>	<b>41</b>	<b>5</b>	<b>639</b>	<b>138</b>	<b>28</b>	<b>2</b>	<b>2823</b>
*** BREAK ***																	
15:30	45	77	24	0	8	26	96	0	12	136	16	0	115	17	6	0	578
15:45	51	84	29	0	12	15	96	0	14	104	14	0	128	19	7	0	573
<b>Total</b>	<b>96</b>	<b>161</b>	<b>53</b>	<b>0</b>	<b>20</b>	<b>41</b>	<b>192</b>	<b>0</b>	<b>26</b>	<b>240</b>	<b>30</b>	<b>0</b>	<b>243</b>	<b>36</b>	<b>13</b>	<b>0</b>	<b>1151</b>
16:00	69	69	27	0	7	15	82	0	10	119	12	0	109	19	2	0	540
16:15	74	75	24	0	12	22	89	0	18	108	16	0	136	26	7	0	607
16:30	82	92	23	0	17	21	106	0	16	134	17	0	109	15	3	0	635
16:45	70	69	28	0	8	27	87	0	7	136	16	0	118	26	7	0	599
<b>Total</b>	<b>295</b>	<b>305</b>	<b>102</b>	<b>0</b>	<b>44</b>	<b>85</b>	<b>364</b>	<b>0</b>	<b>51</b>	<b>497</b>	<b>61</b>	<b>0</b>	<b>472</b>	<b>86</b>	<b>19</b>	<b>0</b>	<b>2381</b>
17:00	80	92	22	0	3	24	108	0	11	134	12	0	141	16	8	0	651
17:15	87	85	31	0	7	18	125	0	19	136	11	0	136	20	9	0	684
17:30	78	79	26	0	6	14	88	0	12	144	15	0	137	17	3	0	619
17:45	92	94	23	0	10	20	132	0	17	131	22	0	117	16	2	0	676
<b>Total</b>	<b>337</b>	<b>350</b>	<b>102</b>	<b>0</b>	<b>26</b>	<b>76</b>	<b>453</b>	<b>0</b>	<b>59</b>	<b>545</b>	<b>60</b>	<b>0</b>	<b>531</b>	<b>69</b>	<b>22</b>	<b>0</b>	<b>2630</b>
18:00	98	83	29	0	10	16	113	0	19	107	13	0	149	20	6	0	663
18:15	71	72	28	0	9	22	99	0	11	131	11	0	131	12	6	0	603
<b>Grand Total</b>	<b>1722</b>	<b>2372</b>	<b>754</b>	<b>0</b>	<b>199</b>	<b>442</b>	<b>2042</b>	<b>2</b>	<b>323</b>	<b>3097</b>	<b>294</b>	<b>6</b>	<b>3034</b>	<b>526</b>	<b>131</b>	<b>3</b>	<b>14947</b>
Apprch %	35.5	48.9	15.6	0	7.4	16.5	76.1	0.1	8.7	83.3	7.9	0.2	82.1	14.2	3.5	0.1	
Total %	11.5	15.9	5	0	1.3	3	13.7	0	2.2	20.7	2	0	20.3	3.5	0.9	0	

# Albeck Gerken, Inc

Transportation Engineers

Traffic Data Collection

Plymouth Rd at Cartway Lane

Ref.Pt.: Minnetonka

Data by: Albeck Gerken Inc

TURN MOVEMENT COUNT

File Name : Plymouth Rd at Cartway Ln 2007

Site Code : 01827121

Start Date : 4/12/2007

Page No : 2

Start Time	Plymouth Rd Southbound					Ridgedale entrance Westbound					Plymouth Rd Northbound					Cartway Lane Eastbound					Int. Total
	Left	Thru	Right	Peds	App. Total	Left	Thru	Right	Peds	App. Total	Left	Thru	Right	Peds	App. Total	Left	Thru	Right	Peds	App. Total	
Peak Hour Analysis From 06:00 to 08:45 - Peak 1 of 1																					
Peak Hour for Entire Intersection Begins at 08:00																					
08:00	14	89	6	0	109	1	0	9	0	10	4	70	1	0	75	43	3	3	0	49	243
08:15	16	96	14	0	126	0	2	11	0	13	3	76	0	0	79	38	6	5	0	49	267
08:30	23	93	14	0	130	2	4	13	0	19	6	65	0	0	71	45	3	2	0	50	270
08:45	33	87	15	0	135	1	8	16	0	25	3	78	3	0	84	64	10	3	0	77	321
Total Volume	86	365	49	0	500	4	14	49	0	67	16	289	4	0	309	190	22	13	0	225	1101
% App. Total	17.2	73	9.8	0		6	20.9	73.1	0		5.2	93.5	1.3	0		84.4	9.8	5.8	0		
PHF	.652	.951	.817	.000	.926	.500	.438	.766	.000	.670	.667	.926	.333	.000	.920	.742	.550	.650	.000	.731	.857

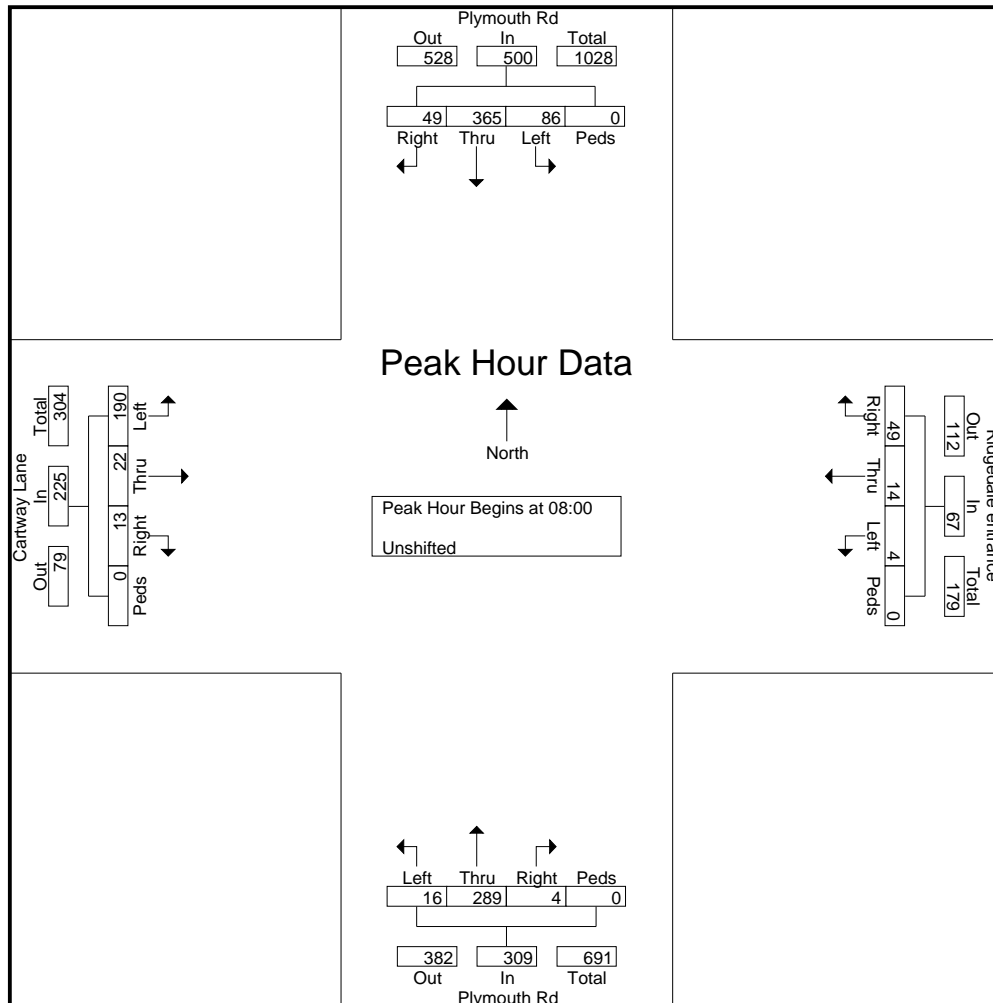

# Albeck Gerken, Inc

Transportation Engineers

Traffic Data Collection

Plymouth Rd at Cartway Lane

Ref.Pt.: Minnetonka

Data by: Albeck Gerken Inc

TURN MOVEMENT COUNT

File Name : Plymouth Rd at Cartway Ln 2007

Site Code : 01827121

Start Date : 4/12/2007

Page No : 3

Start Time	Plymouth Rd Southbound					Ridgedale entrance Westbound					Plymouth Rd Northbound					Cartway Lane Eastbound					Int. Total
	Left	Thru	Right	Peds	App. Total	Left	Thru	Right	Peds	App. Total	Left	Thru	Right	Peds	App. Total	Left	Thru	Right	Peds	App. Total	
Peak Hour Analysis From 15:00 to 18:15 - Peak 1 of 1																					
Peak Hour for Entire Intersection Begins at 17:15																					
17:15	87	85	31	0	203	7	18	125	0	150	19	136	11	0	166	136	20	9	0	165	684
17:30	78	79	26	0	183	6	14	88	0	108	12	144	15	0	171	137	17	3	0	157	619
17:45	92	94	23	0	209	10	20	132	0	162	17	131	22	0	170	117	16	2	0	135	676
18:00	98	83	29	0	210	10	16	113	0	139	19	107	13	0	139	149	20	6	0	175	663
Total Volume	355	341	109	0	805	33	68	458	0	559	67	518	61	0	646	539	73	20	0	632	2642
% App. Total	44.1	42.4	13.5	0		5.9	12.2	81.9	0		10.4	80.2	9.4	0		85.3	11.6	3.2	0		
PHF	.906	.907	.879	.000	.958	.825	.850	.867	.000	.863	.882	.899	.693	.000	.944	.904	.913	.556	.000	.903	.966

