

Albeck Gerken, Inc

Transportation Engineers

Traffic Data Collection

Hopkins Crossroads at Fairfield Rd W.

File Name : Hopkins Crossroads at Fairfield Rd W 2007

Ref.Pt.: Minnetonka

Site Code : 00182718

Data by: Albeck Gerken Inc

Start Date : 4/11/2007

TURN MOVEMENT COUNT

Page No : 1

Groups Printed- Unshifted

Start Time	Hopkins Crossroads / CSAH-73 Southbound				Fairfield Rd W Westbound				Hopkins Crossroads / CSAH-73 Northbound				Fairfield Rd W Eastbound				Int. Total
	Left	Thru	Right	Peds	Left	Thru	Right	Peds	Left	Thru	Right	Peds	Left	Thru	Right	Peds	
06:00	6	12	1	0	2	0	0	0	3	11	4	0	2	0	1	0	42
06:15	4	33	0	1	3	0	0	0	1	16	10	0	1	0	5	1	75
06:30	0	51	1	0	8	0	1	0	1	17	11	0	1	1	3	0	95
06:45	16	72	0	0	6	1	0	0	1	34	13	0	3	0	5	0	151
Total	26	168	2	1	19	1	1	0	6	78	38	0	7	1	14	1	363
07:00	18	76	1	1	16	1	0	0	4	35	27	0	4	0	3	0	186
07:15	16	77	2	0	7	0	0	1	2	50	16	1	2	1	4	0	179
07:30	29	85	2	0	11	0	4	0	1	41	29	0	0	0	5	0	207
07:45	37	92	1	0	10	0	2	0	4	56	37	0	0	1	3	0	243
Total	100	330	6	1	44	1	6	1	11	182	109	1	6	2	15	0	815
08:00	34	90	2	0	14	0	1	0	4	35	32	0	10	3	5	0	230
08:15	38	82	3	0	7	0	1	0	9	42	43	0	4	1	4	0	234
08:30	30	72	5	0	11	0	2	0	4	23	24	0	3	0	8	0	182
08:45	24	62	6	0	9	0	3	0	7	46	31	0	0	1	5	0	194
Total	126	306	16	0	41	0	7	0	24	146	130	0	17	5	22	0	840
*** BREAK ***																	
11:00	2	21	3	0	12	3	5	0	3	36	4	0	3	0	8	0	100
11:15	4	23	2	0	8	1	2	0	7	32	5	0	3	0	16	0	103
11:30	1	33	1	0	17	1	5	0	8	31	4	0	2	0	3	0	106
11:45	3	26	6	0	9	1	5	0	24	39	8	2	4	0	5	0	132
Total	10	103	12	0	46	6	17	0	42	138	21	2	12	0	32	0	441
12:00	6	36	6	0	11	1	13	0	11	45	14	0	8	0	11	0	162
12:15	4	28	3	0	7	4	6	0	8	32	11	0	4	1	13	0	121
12:30	3	37	2	0	14	3	1	0	5	38	9	0	5	3	8	0	128
12:45	8	41	1	0	8	0	4	0	10	37	19	0	1	5	6	0	140
Total	21	142	12	0	40	8	24	0	34	152	53	0	18	9	38	0	551
*** BREAK ***																	
15:00	2	36	1	0	15	0	6	0	8	69	6	0	2	0	6	0	151
15:15	2	47	1	0	12	0	6	0	7	59	5	0	1	0	5	0	145
15:30	2	33	2	0	17	0	12	0	11	91	10	0	0	1	5	0	184
15:45	2	54	6	0	13	2	9	0	10	75	3	2	4	0	3	0	183
Total	8	170	10	0	57	2	33	0	36	294	24	2	7	1	19	0	663
16:00	0	45	3	0	11	1	24	0	2	67	6	0	4	0	3	1	167
16:15	2	40	4	0	23	0	26	0	10	102	10	0	1	1	6	0	225
16:30	0	57	1	1	26	1	26	0	8	97	6	0	2	0	3	1	229
16:45	0	65	2	0	13	1	22	1	8	119	8	0	3	1	10	0	253
Total	2	207	10	1	73	3	98	1	28	385	30	0	10	2	22	2	874
17:00	0	76	4	0	36	2	59	0	8	120	14	0	6	1	9	0	335
17:15	4	88	8	0	22	1	28	0	18	125	10	0	5	1	6	0	316
17:30	2	66	3	0	28	2	25	0	12	112	8	0	6	0	7	0	271
17:45	0	49	2	0	8	1	17	0	16	90	14	0	4	0	8	0	209
Total	6	279	17	0	94	6	129	0	54	447	46	0	21	2	30	0	1131
Grand Total	299	1705	85	3	414	27	315	2	235	1822	451	5	98	22	192	3	5678
Apprch %	14.3	81.5	4.1	0.1	54.6	3.6	41.6	0.3	9.4	72.5	17.9	0.2	31.1	7	61	1	
Total %	5.3	30	1.5	0.1	7.3	0.5	5.5	0	4.1	32.1	7.9	0.1	1.7	0.4	3.4	0.1	

Albeck Gerken, Inc

Transportation Engineers

Traffic Data Collection

Hopkins Crossroads at Fairfield Rd W.
 Ref.Pt.: Minnetonka
 Data by: Albeck Gerken Inc
 TURN MOVEMENT COUNT

File Name : Hopkins Crossroads at Fairfield Rd W 2007
 Site Code : 00182718
 Start Date : 4/11/2007
 Page No : 2

Start Time	Hopkins Crossroads / CSAH-73 Southbound					Fairfield Rd W Westbound					Hopkins Crossroads / CSAH-73 Northbound					Fairfield Rd W Eastbound					Int. Total
	Left	Thru	Right	Peds	App. Total	Left	Thru	Right	Peds	App. Total	Left	Thru	Right	Peds	App. Total	Left	Thru	Right	Peds	App. Total	
Peak Hour Analysis From 06:00 to 08:45 - Peak 1 of 1																					
Peak Hour for Entire Intersection Begins at 07:30																					
07:30	29	85	2	0	116	11	0	4	0	15	1	41	29	0	71	0	0	5	0	5	207
07:45	37	92	1	0	130	10	0	2	0	12	4	56	37	0	97	0	1	3	0	4	243
08:00	34	90	2	0	126	14	0	1	0	15	4	35	32	0	71	10	3	5	0	18	230
08:15	38	82	3	0	123	7	0	1	0	8	9	42	43	0	94	4	1	4	0	9	234
Total Volume	138	349	8	0	495	42	0	8	0	50	18	174	141	0	333	14	5	17	0	36	914
% App. Total	27.9	70.5	1.6	0		8.4	0	1.6	0		5.4	52.3	42.3	0		38.9	13.9	47.2	0		
PHF	.908	.948	.667	.000	.952	.750	.000	.500	.000	.833	.500	.777	.820	.000	.858	.350	.417	.850	.000	.500	.940

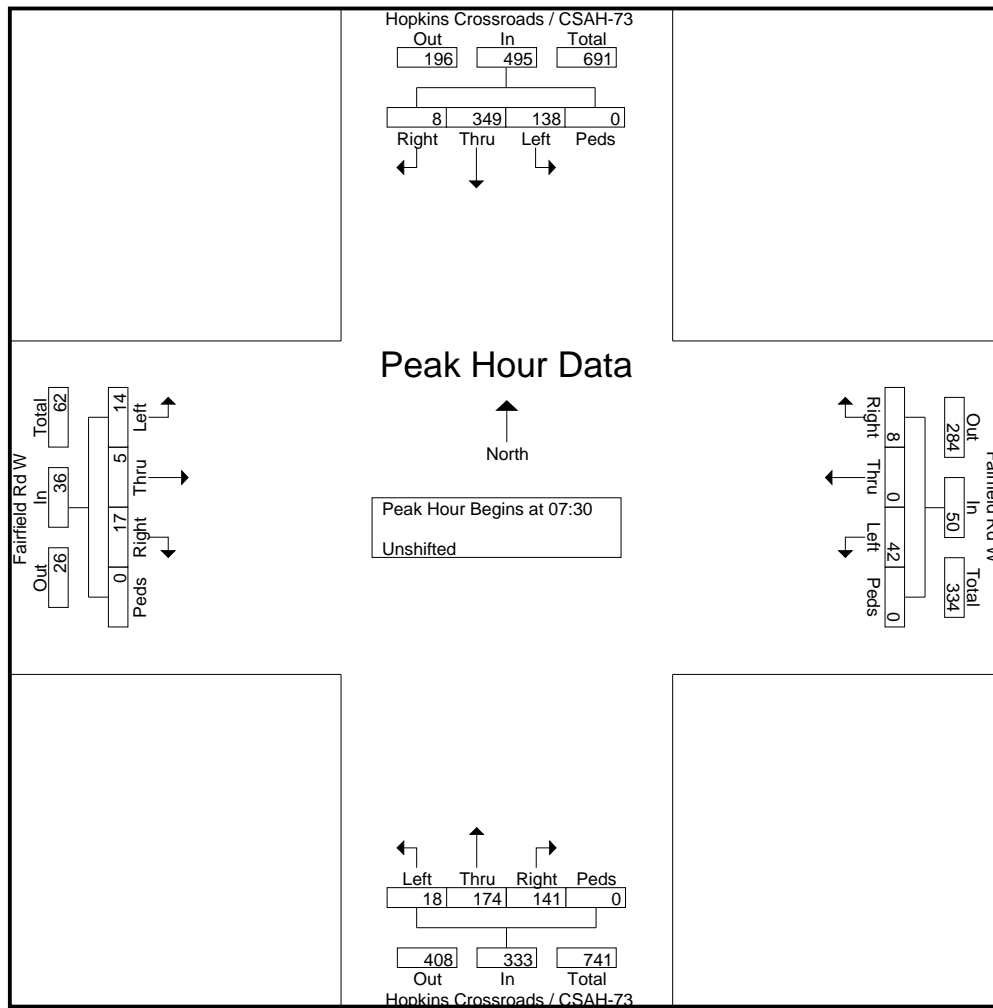

Albeck Gerken, Inc

Transportation Engineers

Traffic Data Collection

Hopkins Crossroads at Fairfield Rd W.
 Ref.Pt.: Minnetonka
 Data by: Albeck Gerken Inc
 TURN MOVEMENT COUNT

File Name : Hopkins Crossroads at Fairfield Rd W 2007
 Site Code : 00182718
 Start Date : 4/11/2007
 Page No : 3

Start Time	Hopkins Crossroads / CSAH-73 Southbound					Fairfield Rd W Westbound					Hopkins Crossroads / CSAH-73 Northbound					Fairfield Rd W Eastbound					Int. Total
	Left	Thru	Right	Peds	App. Total	Left	Thru	Right	Peds	App. Total	Left	Thru	Right	Peds	App. Total	Left	Thru	Right	Peds	App. Total	
16:45	0	65	2	0	67	13	1	22	1	37	8	119	8	0	135	3	1	10	0	14	253
17:00	0	76	4	0	80	36	2	59	0	97	8	120	14	0	142	6	1	9	0	16	335
17:15	4	88	8	0	100	22	1	28	0	51	18	125	10	0	153	5	1	6	0	12	316
17:30	2	66	3	0	71	28	2	25	0	55	12	112	8	0	132	6	0	7	0	13	271
Total Volume	6	295	17	0	318	99	6	134	1	240	46	476	40	0	562	20	3	32	0	55	1175
% App. Total	1.9	92.8	5.3	0		41.2	2.5	55.8	0.4		8.2	84.7	7.1	0		36.4	5.5	58.2	0		
PHF	.375	.838	.531	.000	.795	.688	.750	.568	.250	.619	.639	.952	.714	.000	.918	.833	.750	.800	.000	.859	.877

Peak Hour Analysis From 15:00 to 17:45 - Peak 1 of 1
 Peak Hour for Entire Intersection Begins at 16:45

