

Albeck Gerken, Inc

Transportation Engineers

Traffic Data Collection

Hopkins Crossroads at N Frt Rd (I-394)

File Name : Hopkins Crossroads at N Frt Rd I-394 2007

Ref.Pt.: Minnetonka

Site Code : 01827110

Data by: Albeck Gerken Inc

Start Date : 4/11/2007

TURN MOVEMENT COUNT

Page No : 1

Groups Printed- Unshifted

Start Time	Hopkins Crossroads Southbound				N Frontage Rd (I-394) Westbound				Hopkins Crossroads Northbound				N Frontage Rd (I-394) Eastbound				Int. Total
	Left	Thru	Right	Peds	Left	Thru	Right	Peds	Left	Thru	Right	Peds	Left	Thru	Right	Peds	
06:00	1	8	5	0	4	1	0	0	7	17	12	0	1	0	1	0	57
06:15	3	34	4	0	1	0	1	0	13	24	21	0	2	4	7	0	114
06:30	4	44	10	0	5	3	3	0	14	27	35	0	1	2	6	0	154
06:45	10	63	16	0	8	5	2	0	38	43	38	0	3	4	9	0	239
Total	18	149	35	0	18	9	6	0	72	111	106	0	7	10	23	0	564
07:00	5	70	18	0	12	8	3	0	37	55	43	0	5	9	14	0	279
07:15	12	80	11	0	19	2	2	0	34	54	69	0	11	12	9	0	315
07:30	11	87	18	0	21	14	3	0	33	62	82	0	8	15	19	0	373
07:45	12	82	23	0	13	12	8	0	44	81	93	0	9	26	17	0	420
Total	40	319	70	0	65	36	16	0	148	252	287	0	33	62	59	0	1387
08:00	9	80	29	1	15	9	3	0	42	67	110	0	8	19	22	0	414
08:15	6	71	19	0	11	10	3	0	38	81	106	0	5	31	19	0	400
08:30	9	69	16	0	14	9	5	0	34	45	59	0	3	14	15	0	292
08:45	7	61	15	0	14	8	1	0	46	77	73	0	6	15	18	0	341
Total	31	281	79	1	54	36	12	0	160	270	348	0	22	79	74	0	1447
*** BREAK ***																	
11:00	1	33	8	0	17	14	4	0	61	29	21	0	10	9	21	0	228
11:15	0	39	8	1	33	17	3	0	68	35	26	0	7	8	33	0	278
11:30	3	28	28	0	28	28	5	0	52	31	35	0	5	6	32	0	281
11:45	3	18	18	0	36	43	4	0	70	54	30	0	14	11	35	0	336
Total	7	118	62	1	114	102	16	0	251	149	112	0	36	34	121	0	1123
12:00	4	46	14	2	25	32	5	0	60	46	29	0	20	16	41	0	340
12:15	6	33	14	0	25	26	9	0	71	35	44	0	10	23	55	0	351
12:30	3	40	16	0	34	9	3	0	50	34	39	0	16	26	48	0	318
12:45	3	36	16	2	28	15	5	0	56	31	46	0	24	33	65	0	360
Total	16	155	60	4	112	82	22	0	237	146	158	0	70	98	209	0	1369
*** BREAK ***																	
15:00	2	41	9	0	32	13	6	0	45	59	25	0	12	19	59	0	322
15:15	3	57	11	0	28	8	6	0	55	52	21	0	14	8	56	0	319
15:30	1	47	7	0	28	5	3	0	63	90	17	0	20	7	51	0	339
15:45	8	55	10	0	35	12	11	0	55	61	36	0	14	12	43	0	352
Total	14	200	37	0	123	38	26	0	218	262	99	0	60	46	209	0	1332
16:00	1	35	19	1	58	15	6	0	58	54	17	0	14	11	45	0	334
16:15	2	55	11	0	48	17	16	0	66	90	22	0	22	12	47	0	408
16:30	2	78	10	0	63	18	14	0	74	77	31	0	16	9	55	0	447
16:45	9	56	18	0	53	29	10	0	51	98	38	0	26	11	47	0	446
Total	14	224	58	1	222	79	46	0	249	319	108	0	78	43	194	0	1635
17:00	6	80	27	0	84	23	25	0	67	80	21	0	28	25	63	0	529
17:15	2	90	42	0	73	30	16	0	81	109	37	0	25	16	71	0	592
17:30	4	80	28	0	79	34	10	0	77	107	28	0	16	13	52	0	528
17:45	1	55	17	2	53	24	15	0	78	82	36	0	25	6	59	0	453
Total	13	305	114	2	289	111	66	0	303	378	122	0	94	60	245	0	2102
Grand Total	153	1751	515	9	997	493	210	0	1638	1887	1340	0	400	432	1134	0	10959
Apprch %	6.3	72.1	21.2	0.4	58.6	29	12.4	0	33.7	38.8	27.5	0	20.3	22	57.7	0	
Total %	1.4	16	4.7	0.1	9.1	4.5	1.9	0	14.9	17.2	12.2	0	3.6	3.9	10.3	0	

Albeck Gerken, Inc

Transportation Engineers

Traffic Data Collection

Hopkins Crossroads at N Frt Rd (I-394)

File Name : Hopkins Crossroads at N Frt Rd I-394 2007

Ref.Pt.: Minnetonka

Site Code : 01827110

Data by: Albeck Gerken Inc

Start Date : 4/11/2007

TURN MOVEMENT COUNT

Page No : 2

Start Time	Hopkins Crossroads Southbound					N Frontage Rd (I-394) Westbound					Hopkins Crossroads Northbound					N Frontage Rd (I-394) Eastbound					Int. Total
	Left	Thru	Right	Peds	App. Total	Left	Thru	Right	Peds	App. Total	Left	Thru	Right	Peds	App. Total	Left	Thru	Right	Peds	App. Total	
Peak Hour Analysis From 06:00 to 08:45 - Peak 1 of 1																					
Peak Hour for Entire Intersection Begins at 07:30																					
07:30	11	87	18	0	116	21	14	3	0	38	33	62	82	0	177	8	15	19	0	42	373
07:45	12	82	23	0	117	13	12	8	0	33	44	81	93	0	218	9	26	17	0	52	420
08:00	9	80	29	1	119	15	9	3	0	27	42	67	110	0	219	8	19	22	0	49	414
08:15	6	71	19	0	96	11	10	3	0	24	38	81	106	0	225	5	31	19	0	55	400
Total Volume	38	320	89	1	448	60	45	17	0	122	157	291	391	0	839	30	91	77	0	198	1607
% App. Total	8.5	71.4	19.9	0.2		49.2	36.9	13.9	0		18.7	34.7	46.6	0		15.2	46	38.9	0		
PHF	.792	.920	.767	.250	.941	.714	.804	.531	.000	.803	.892	.898	.889	.000	.932	.833	.734	.875	.000	.900	.957

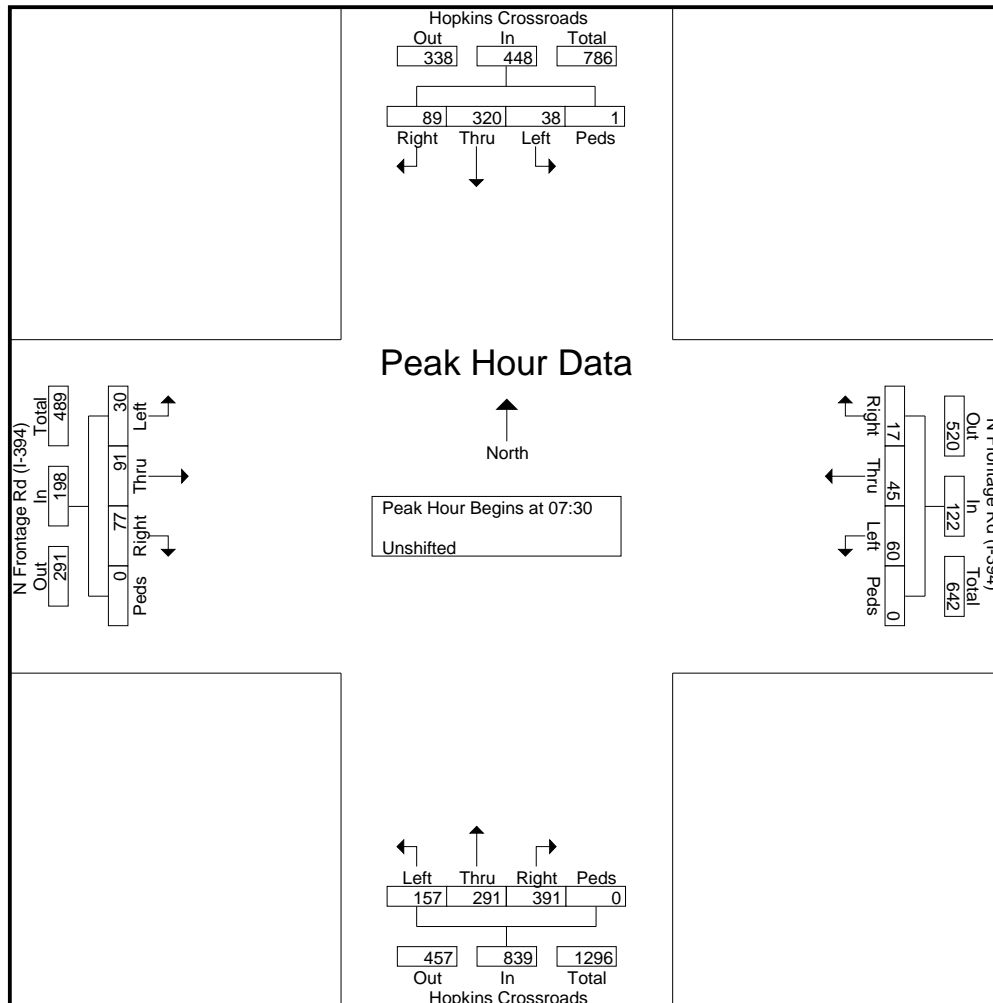

Albeck Gerken, Inc

Transportation Engineers

Traffic Data Collection

Hopkins Crossroads at N Frt Rd (I-394)

File Name : Hopkins Crossroads at N Frt Rd I-394 2007

Ref.Pt.: Minnetonka

Site Code : 01827110

Data by: Albeck Gerken Inc

Start Date : 4/11/2007

TURN MOVEMENT COUNT

Page No : 3

Start Time	Hopkins Crossroads Southbound					N Frontage Rd (I-394) Westbound					Hopkins Crossroads Northbound					N Frontage Rd (I-394) Eastbound					Int. Total
	Left	Thru	Right	Peds	App. Total	Left	Thru	Right	Peds	App. Total	Left	Thru	Right	Peds	App. Total	Left	Thru	Right	Peds	App. Total	
Peak Hour Analysis From 15:00 to 17:45 - Peak 1 of 1																					
Peak Hour for Entire Intersection Begins at 17:00																					
17:00	6	80	27	0	113	84	23	25	0	132	67	80	21	0	168	28	25	63	0	116	529
17:15	2	90	42	0	134	73	30	16	0	119	81	109	37	0	227	25	16	71	0	112	592
17:30	4	80	28	0	112	79	34	10	0	123	77	107	28	0	212	16	13	52	0	81	528
17:45	1	55	17	2	75	53	24	15	0	92	78	82	36	0	196	25	6	59	0	90	453
Total Volume	13	305	114	2	434	289	111	66	0	466	303	378	122	0	803	94	60	245	0	399	2102
% App. Total	3	70.3	26.3	0.5		62	23.8	14.2	0		37.7	47.1	15.2	0		23.6	15	61.4	0		
PHF	.542	.847	.679	.250	.810	.860	.816	.660	.000	.883	.935	.867	.824	.000	.884	.839	.600	.863	.000	.860	.888

