

MN Dept of Transportation

TRAFFIC DATA COLLECTION - Metro

I-394 south frt rd at Hopkins Crossroad

Ref.Pt.: 001.941

video RE

TURN MOVEMENT COUNT

File Name : I-394 south frt rd at Hopkins Crossroads 2015

Site Code :

Start Date : 2/4/2015

Page No : 1

Groups Printed- Cars +

Start Time	Hopkins Crossroad Southbound				I-394 south frontage rd Westbound				Hopkins Crossroad Northbound				I-394 south frontage rd Eastbound				Int. Total
	Left	Thru	Right	Peds	Left	Thru	Right	Peds	Left	Thru	Right	Peds	Left	Thru	Right	Peds	
06:00	8	18	4	0	3	3	3	0	10	17	4	0	3	0	0	0	73
06:15	7	28	13	0	3	1	5	0	11	37	3	0	2	1	4	0	115
06:30	18	40	13	0	2	6	6	0	12	53	8	0	3	6	3	0	170
06:45	24	47	17	0	6	9	7	0	18	58	8	0	3	3	6	0	206
Total	57	133	47	0	14	19	21	0	51	165	23	0	11	10	13	0	564
07:00	39	64	37	0	4	6	7	0	28	98	15	0	7	4	3	0	312
07:15	30	117	28	0	6	7	12	0	23	111	37	0	9	10	10	0	400
07:30	36	88	27	0	13	15	15	0	31	157	31	0	5	6	11	0	435
07:45	31	76	13	0	8	5	9	0	34	176	49	0	3	11	11	0	426
Total	136	345	105	0	31	33	43	0	116	542	132	0	24	31	35	0	1573
08:00	42	96	26	0	10	4	15	0	21	142	46	0	7	10	3	0	422
08:15	53	90	22	0	6	7	8	0	20	143	41	0	1	10	5	0	406
08:30	37	85	5	0	14	3	16	0	5	101	25	0	2	7	5	0	305
08:45	34	93	10	0	12	6	11	0	12	119	20	0	3	3	9	0	332
Total	166	364	63	0	42	20	50	0	58	505	132	0	13	30	22	0	1465
*****BREAK*****																	
15:00	10	87	4	0	11	13	18	0	12	98	10	0	4	8	15	0	290
15:15	16	94	10	0	13	6	25	0	16	87	9	0	6	9	16	0	307
15:30	12	102	4	0	13	8	29	0	12	117	16	0	7	7	12	0	339
15:45	21	101	9	0	17	10	26	0	18	129	11	0	15	6	8	0	371
Total	59	384	27	0	54	37	98	0	58	431	46	0	32	30	51	0	1307
16:00	17	103	9	0	34	15	57	0	18	99	15	0	25	10	31	0	433
16:15	13	109	6	0	23	21	43	0	14	133	14	0	5	16	19	0	416
16:30	12	118	12	0	27	20	43	0	14	148	15	0	18	12	26	0	465
16:45	16	139	21	0	23	28	41	0	18	145	18	0	21	8	41	0	519
Total	58	469	48	0	107	84	184	0	64	525	62	0	69	46	117	0	1833
17:00	14	145	12	0	45	27	47	0	26	135	16	0	26	16	52	0	561
17:15	4	200	21	0	32	28	43	0	31	137	16	0	33	8	38	0	591
17:30	12	180	12	0	30	26	24	0	26	146	15	0	33	16	48	0	568
17:45	22	153	11	0	17	18	35	0	16	129	14	0	19	11	38	0	483
Total	52	678	56	0	124	99	149	0	99	547	61	0	111	51	176	0	2203
Grand Total	528	2373	346	0	372	292	545	0	446	2715	456	0	260	198	414	0	8945
Apprch %	16.3	73.1	10.7	0	30.8	24.2	45.1	0	12.3	75.1	12.6	0	29.8	22.7	47.5	0	
Total %	5.9	26.5	3.9	0	4.2	3.3	6.1	0	5	30.4	5.1	0	2.9	2.2	4.6	0	

MN Dept of Transportation

TRAFFIC DATA COLLECTION - Metro

I-394 south frt rd at Hopkins Crossroad
 Ref.Pt.: 001.941
 video RE
 TURN MOVEMENT COUNT

File Name : I-394 south frt rd at Hopkins Crossroads 2015
 Site Code :
 Start Date : 2/4/2015
 Page No : 2

Start Time	Hopkins Crossroad Southbound					I-394 south frontage rd Westbound					Hopkins Crossroad Northbound					I-394 south frontage rd Eastbound					Int. Total
	Left	Thru	Right	Peds	App. Total	Left	Thru	Right	Peds	App. Total	Left	Thru	Right	Peds	App. Total	Left	Thru	Right	Peds	App. Total	
Peak Hour Analysis From 06:00 to 08:45 - Peak 1 of 1																					
Peak Hour for Entire Intersection Begins at 07:30																					
07:30	36	88	27	0	151	13	15	15	0	43	31	157	31	0	219	5	6	11	0	22	435
07:45	31	76	13	0	120	8	5	9	0	22	34	176	49	0	259	3	11	11	0	25	426
08:00	42	96	26	0	164	10	4	15	0	29	21	142	46	0	209	7	10	3	0	20	422
08:15	53	90	22	0	165	6	7	8	0	21	20	143	41	0	204	1	10	5	0	16	406
Total Volume	162	350	88	0	600	37	31	47	0	115	106	618	167	0	891	16	37	30	0	83	1689
% App. Total	27	58.3	14.7	0		32.2	27	40.9	0		11.9	69.4	18.7	0		19.3	44.6	36.1	0		
PHF	.764	.911	.815	.000	.909	.712	.517	.783	.000	.669	.779	.878	.852	.000	.860	.571	.841	.682	.000	.830	.971

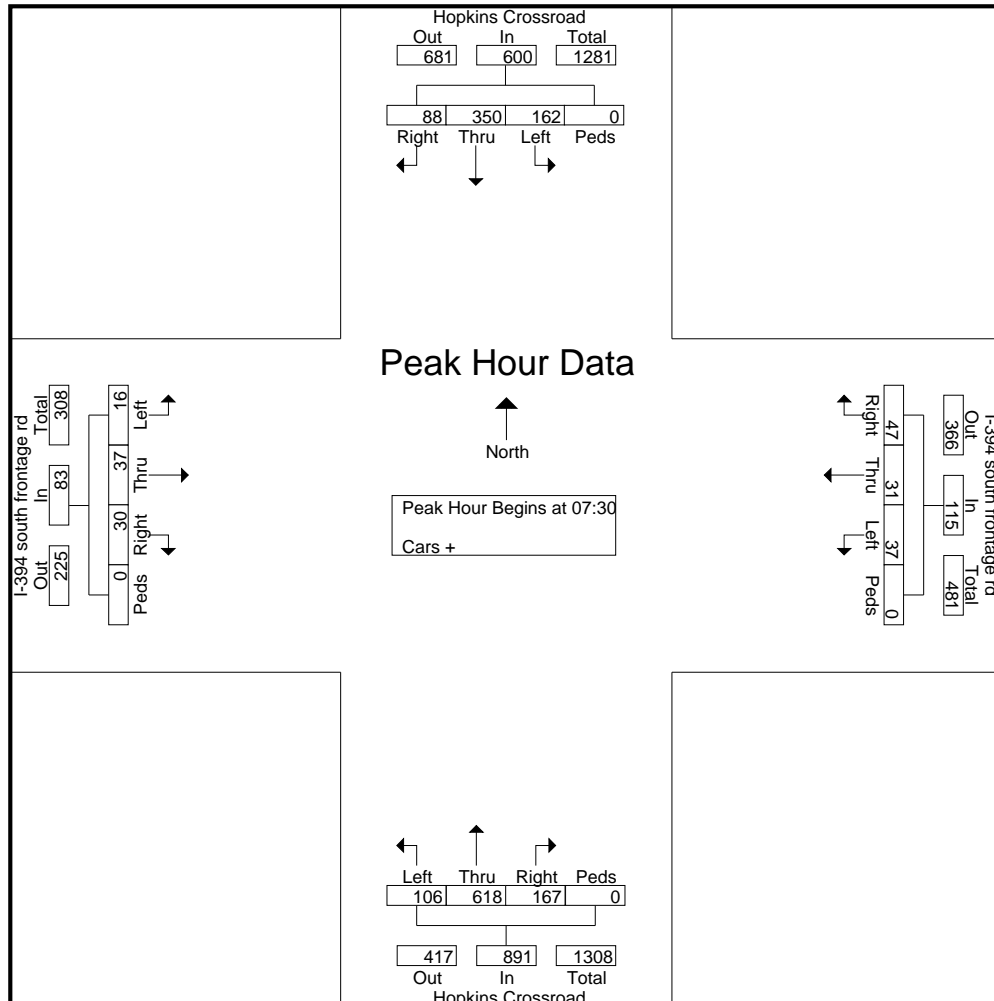

MN Dept of Transportation

TRAFFIC DATA COLLECTION - Metro

I-394 south frt rd at Hopkins Crossroad
 Ref.Pt.: 001.941
 video RE
 TURN MOVEMENT COUNT

File Name : I-394 south frt rd at Hopkins Crossroads 2015
 Site Code :
 Start Date : 2/4/2015
 Page No : 3

Start Time	Hopkins Crossroad Southbound					I-394 south frontage rd Westbound					Hopkins Crossroad Northbound					I-394 south frontage rd Eastbound					Int. Total
	Left	Thru	Right	Peds	App. Total	Left	Thru	Right	Peds	App. Total	Left	Thru	Right	Peds	App. Total	Left	Thru	Right	Peds	App. Total	
Peak Hour Analysis From 15:00 to 17:45 - Peak 1 of 1																					
Peak Hour for Entire Intersection Begins at 16:45																					
16:45	16	139	21	0	176	23	28	41	0	92	18	145	18	0	181	21	8	41	0	70	519
17:00	14	145	12	0	171	45	27	47	0	119	26	135	16	0	177	26	16	52	0	94	561
17:15	4	200	21	0	225	32	28	43	0	103	31	137	16	0	184	33	8	38	0	79	591
17:30	12	180	12	0	204	30	26	24	0	80	26	146	15	0	187	33	16	48	0	97	568
Total Volume	46	664	66	0	776	130	109	155	0	394	101	563	65	0	729	113	48	179	0	340	2239
% App. Total	5.9	85.6	8.5	0		33	27.7	39.3	0		13.9	77.2	8.9	0		33.2	14.1	52.6	0		
PHF	.719	.830	.786	.000	.862	.722	.973	.824	.000	.828	.815	.964	.903	.000	.975	.856	.750	.861	.000	.876	.947

