



MINNESOTA DEPT OF TRANSPORTATION

TRAFFIC DATA COLLECTION - METRO

Louisiana Ave at Wayzata Blvd / S Frt File Name : LOUISIANA BLVD AT WAYZATA BLVD ampm 2007
 REF.PT.: 004.455xx Site Code : 00000000
 JAMAR # 632/631 DR/ RE Start Date : 4/5/2007
 TURN MOVEMENT COUNT Page No : 1

Groups Printed- Cars & Trucks

Start Time	LOUISIANA AVE Southbound				Wayzata Blvd / S Frontage Rd Westbound				LOUISIANA AVE Northbound				Wayzata Blvd / S Frontage Rd Eastbound				Int. Total
	Left	Thru	Right	Peds	Left	Thru	Right	Peds	Left	Thru	Right	Peds	Left	Thru	Right	Peds	
06:00	13	33	7	0	0	3	11	0	2	46	2	0	11	2	5	0	135
06:15	18	35	21	0	3	3	20	0	5	38	3	0	15	7	7	0	175
06:30	25	43	12	0	1	4	24	0	4	56	1	0	16	13	6	0	205
06:45	38	68	16	0	0	7	34	0	16	95	9	0	9	9	12	0	313
Total	94	179	56	0	4	17	89	0	27	235	15	0	51	31	30	0	828
07:00	29	43	31	0	1	6	23	3	12	85	8	2	26	13	16	0	298
07:15	34	40	14	0	4	10	32	2	12	95	7	2	21	30	16	0	319
07:30	2	4	31	0	1	16	49	0	21	102	5	1	50	29	18	0	329
07:45	57	64	21	0	4	16	56	0	24	143	8	1	40	31	23	0	488
Total	122	151	97	0	10	48	160	5	69	425	28	6	137	103	73	0	1434
08:00	71	52	23	0	3	8	41	0	18	101	10	0	38	29	20	0	414
08:15	60	41	21	0	1	13	49	1	10	83	6	2	19	19	14	0	339
08:30	62	35	25	0	3	16	43	0	16	97	8	0	28	29	14	1	377
08:45	51	66	25	0	6	13	53	1	3	106	14	1	24	8	12	0	383
Total	244	194	94	0	13	50	186	2	47	387	38	3	109	85	60	1	1513
*** BREAK ***																	
15:00	52	86	17	0	6	15	54	0	6	72	4	0	28	13	11	0	364
15:15	36	88	18	0	3	13	70	0	8	94	11	0	21	11	10	0	383
15:30	49	79	29	0	7	19	74	0	12	82	5	0	25	17	16	0	414
15:45	43	80	37	0	11	8	78	0	17	84	11	0	19	17	16	3	424
Total	180	333	101	0	27	55	276	0	43	332	31	0	93	58	53	3	1585
16:00	36	106	36	0	11	19	81	1	9	88	11	0	30	17	13	0	458
16:15	51	107	35	0	12	19	82	0	11	107	9	0	26	26	23	1	509
16:30	46	99	34	0	12	16	130	0	9	97	16	0	35	16	30	2	542
16:45	56	115	45	0	19	18	87	0	19	105	9	0	35	28	34	1	571
Total	189	427	150	0	54	72	380	1	48	397	45	0	126	87	100	4	2080
17:00	61	111	42	0	14	22	84	0	22	86	11	1	52	36	40	1	583
17:15	92	123	71	2	11	22	116	1	19	98	23	0	43	39	34	0	694
17:30	78	134	56	0	11	17	101	0	12	121	15	0	33	26	22	3	629
17:45	87	120	38	0	10	27	95	0	9	113	20	0	24	26	21	1	591
Total	318	488	207	2	46	88	396	1	62	418	69	1	152	127	117	5	2497
Grand Total	1147	1772	705	2	154	330	1487	9	296	2194	226	10	668	491	433	13	9937
Apprch %	31.6	48.9	19.4	0.1	7.8	16.7	75.1	0.5	10.9	80.5	8.3	0.4	41.6	30.6	27	0.8	
Total %	11.5	17.8	7.1	0	1.5	3.3	15	0.1	3	22.1	2.3	0.1	6.7	4.9	4.4	0.1	



MINNESOTA DEPT OF TRANSPORTATION

TRAFFIC DATA COLLECTION - METRO

Louisiana Ave at Wayzata Blvd / S Frt Rd File Name : LOUISIANA BLVD AT WAYZATA BLVD ampm 2007
 REF.PT.: 004.455xx Site Code : 00000000
 JAMAR # 632/631 DR/ RE Start Date : 4/5/2007
 TURN MOVEMENT COUNT Page No : 2

Start Time	LOUISIANA AVE Southbound					Wayzata Blvd / S Frontage Rd Westbound					LOUISIANA AVE Northbound					Wayzata Blvd / S Frontage Rd Eastbound					Int. Total
	Left	Thru	Right	Peds	App. Total	Left	Thru	Right	Peds	App. Total	Left	Thru	Right	Peds	App. Total	Left	Thru	Right	Peds	App. Total	
Peak Hour Analysis From 06:00 to 08:45 - Peak 1 of 1																					
Peak Hour for Entire Intersection Begins at 07:45																					
07:45	57	64	21	0	142	4	16	56	0	76	24	143	8	1	176	40	31	23	0	94	488
08:00	71	52	23	0	146	3	8	41	0	52	18	101	10	0	129	38	29	20	0	87	414
08:15	60	41	21	0	122	1	13	49	1	64	10	83	6	2	101	19	19	14	0	52	339
08:30	62	35	25	0	122	3	16	43	0	62	16	97	8	0	121	28	29	14	1	72	377
Total Volume	250	192	90	0	532	11	53	189	1	254	68	424	32	3	527	125	108	71	1	305	1618
% App. Total																					
PHF	.880	.750	.900	.000	.911	.688	.828	.844	.250	.836	.708	.741	.800	.375	.749	.781	.871	.772	.250	.811	.829

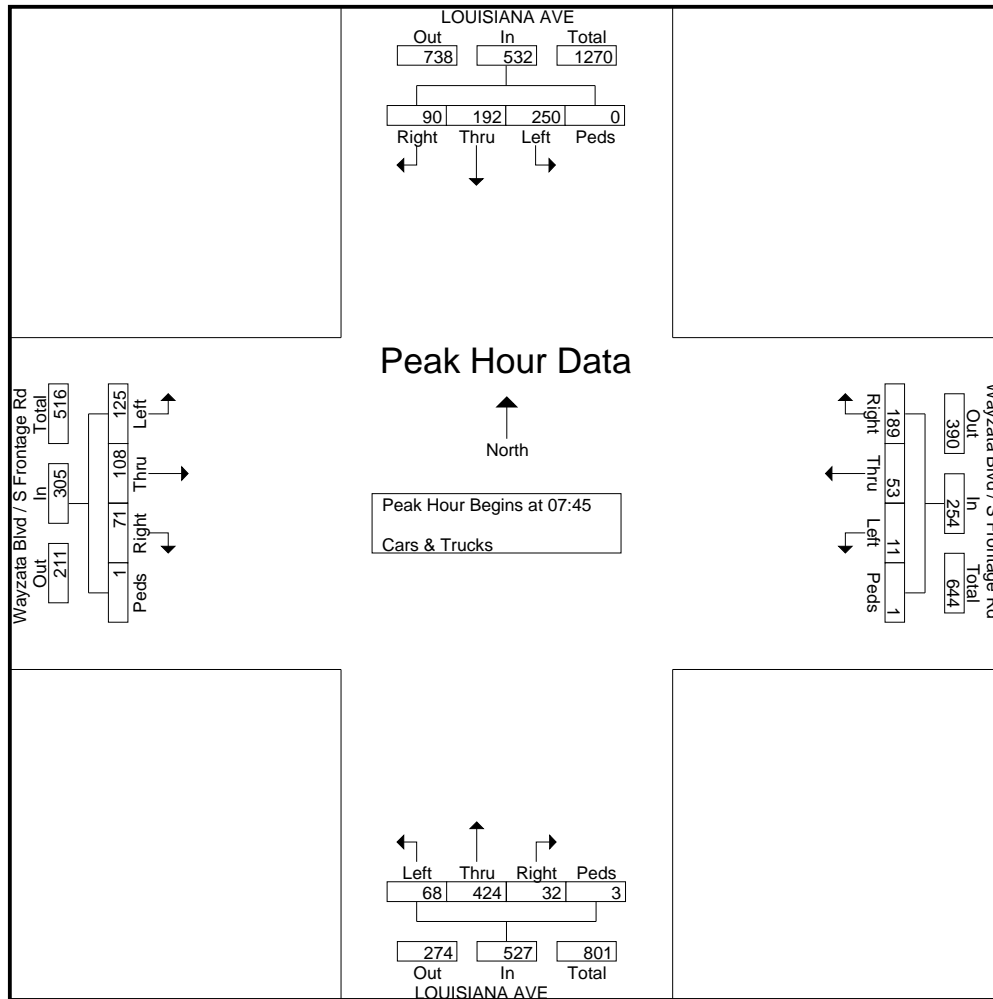



MINNESOTA DEPT OF TRANSPORTATION

TRAFFIC DATA COLLECTION - METRO

Louisiana Ave at Wayzata Blvd / S Frt File Name : LOUISIANA BLVD AT WAYZATA BLVD ampm 2007
 REF.PT.: 004.455xx Site Code : 00000000
 JAMAR # 632/631 DR/ RE Start Date : 4/5/2007
 TURN MOVEMENT COUNT Page No : 3

Start Time	LOUISIANA AVE Southbound					Wayzata Blvd / S Frontage Rd Westbound					LOUISIANA AVE Northbound					Wayzata Blvd / S Frontage Rd Eastbound					Int. Total
	Left	Thru	Right	Peds	App. Total	Left	Thru	Right	Peds	App. Total	Left	Thru	Right	Peds	App. Total	Left	Thru	Right	Peds	App. Total	
Peak Hour Analysis From 15:00 to 17:45 - Peak 1 of 1																					
Peak Hour for Entire Intersection Begins at 17:00																					
17:00	61	111	42	0	214	14	22	84	0	120	22	86	11	1	120	52	36	40	1	129	583
17:15	92	123	71	2	288	11	22	116	1	150	19	98	23	0	140	43	39	34	0	116	694
17:30	78	134	56	0	268	11	17	101	0	129	12	121	15	0	148	33	26	22	3	84	629
17:45	87	120	38	0	245	10	27	95	0	132	9	113	20	0	142	24	26	21	1	72	591
Total Volume	318	488	207	2	1015	46	88	396	1	531	62	418	69	1	550	152	127	117	5	401	2497
% App. Total																					
PHF	.864	.910	.729	.250	.881	.821	.815	.853	.250	.885	.705	.864	.750	.250	.929	.731	.814	.731	.417	.777	.899

