

MN Dept of Transportation

TRAFFIC DATA COLLECTION - Metro

I-494 at 5th Ave, South Ramps

Ref.Pt.: 065.106

video RE

TURN MOVEMENT COUNT

File Name : I-494 at 5th Ave South Ramps 2015

Site Code :

Start Date : 1/27/2015

Page No : 1

Groups Printed- Cars +

Start Time	5th Ave Southbound				ramp to I-494 EB Westbound				5th Ave Northbound				I-494 south frontage rd EB Eastbound				Int. Total
	Left	Thru	Right	Peds	Left	Thru	Right	Peds	Left	Thru	Right	Peds	Left	Thru	Right	Peds	
06:00	15	30	0	0	0	0	0	0	0	41	36	0	0	0	1	0	123
06:15	22	44	0	0	0	0	0	0	0	32	31	0	1	3	5	0	138
06:30	23	39	0	0	0	0	0	0	0	39	45	0	2	6	7	0	161
06:45	33	59	0	0	0	0	0	0	0	45	39	0	2	9	7	0	194
Total	93	172	0	0	0	0	0	0	0	157	151	0	5	18	20	0	616
07:00	28	74	0	0	0	0	0	0	0	52	41	0	4	4	7	0	210
07:15	28	49	0	0	0	0	0	0	0	73	51	0	1	9	11	0	222
07:30	49	76	0	0	0	0	0	0	0	81	50	0	1	5	10	0	272
07:45	33	93	0	0	0	0	0	0	0	65	32	0	7	10	12	0	252
Total	138	292	0	0	0	0	0	0	0	271	174	0	13	28	40	0	956
08:00	30	56	0	0	0	0	0	0	0	49	28	0	4	5	6	0	178
08:15	32	56	0	0	0	0	0	0	0	45	35	0	7	10	9	0	194
08:30	21	68	0	0	0	0	0	0	0	66	32	0	2	8	9	0	206
08:45	29	80	0	0	0	0	0	0	0	86	32	0	4	9	10	0	250
Total	112	260	0	0	0	0	0	0	0	246	127	0	17	32	34	0	828
*****BREAK*****																	
15:00	24	70	0	0	0	0	0	0	0	50	50	0	9	4	17	0	224
15:15	31	86	0	0	0	0	0	0	0	55	49	0	4	9	26	0	260
15:30	29	84	0	0	0	0	0	0	0	84	45	0	5	6	21	0	274
15:45	28	73	0	0	0	0	0	0	0	112	52	0	11	12	10	0	298
Total	112	313	0	0	0	0	0	0	0	301	196	0	29	31	74	0	1056
16:00	19	80	0	0	0	0	0	0	0	76	46	0	12	15	16	0	264
16:15	26	63	0	0	0	0	0	0	0	58	57	0	13	7	20	0	244
16:30	34	80	0	0	0	0	0	0	0	55	53	0	8	9	15	0	254
16:45	23	87	0	0	0	0	0	0	0	83	53	0	14	9	24	0	293
Total	102	310	0	0	0	0	0	0	0	272	209	0	47	40	75	0	1055
17:00	37	85	0	0	0	0	0	0	0	73	76	0	11	16	26	0	324
17:15	44	81	0	0	0	0	0	0	0	67	50	0	12	6	21	0	281
17:30	28	69	0	0	0	0	0	0	0	64	50	0	9	16	24	0	260
17:45	33	72	0	0	0	0	0	0	0	45	34	0	9	10	23	0	226
Total	142	307	0	0	0	0	0	0	0	249	210	0	41	48	94	0	1091
Grand Total	699	1654	0	0	0	0	0	0	0	1496	1067	0	152	197	337	0	5602
Apprch %	29.7	70.3	0	0	0	0	0	0	0	58.4	41.6	0	22.2	28.7	49.1	0	
Total %	12.5	29.5	0	0	0	0	0	0	0	26.7	19	0	2.7	3.5	6	0	

MN Dept of Transportation

TRAFFIC DATA COLLECTION - Metro

I-494 at 5th Ave, South Ramps
 Ref.Pt.: 065.106
 video RE
 TURN MOVEMENT COUNT

File Name : I-494 at 5th Ave South Ramps 2015
 Site Code :
 Start Date : 1/27/2015
 Page No : 2

Start Time	5th Ave Southbound					ramp to I-494 EB Westbound					5th Ave Northbound					I-494 south frontage rd EB Eastbound					Int. Total
	Left	Thru	Right	Peds	App. Total	Left	Thru	Right	Peds	App. Total	Left	Thru	Right	Peds	App. Total	Left	Thru	Right	Peds	App. Total	
Peak Hour Analysis From 06:00 to 08:45 - Peak 1 of 1																					
Peak Hour for Entire Intersection Begins at 07:00																					
07:00	28	74	0	0	102	0	0	0	0	0	0	52	41	0	93	4	4	7	0	15	210
07:15	28	49	0	0	77	0	0	0	0	0	0	73	51	0	124	1	9	11	0	21	222
07:30	49	76	0	0	125	0	0	0	0	0	0	81	50	0	131	1	5	10	0	16	272
07:45	33	93	0	0	126	0	0	0	0	0	0	65	32	0	97	7	10	12	0	29	252
Total Volume	138	292	0	0	430	0	0	0	0	0	0	271	174	0	445	13	28	40	0	81	956
% App. Total	32.1	67.9	0	0		0	0	0	0		0	60.9	39.1	0		16	34.6	49.4	0		
PHF	.704	.785	.000	.000	.853	.000	.000	.000	.000	.000	.000	.836	.853	.000	.849	.464	.700	.833	.000	.698	.879

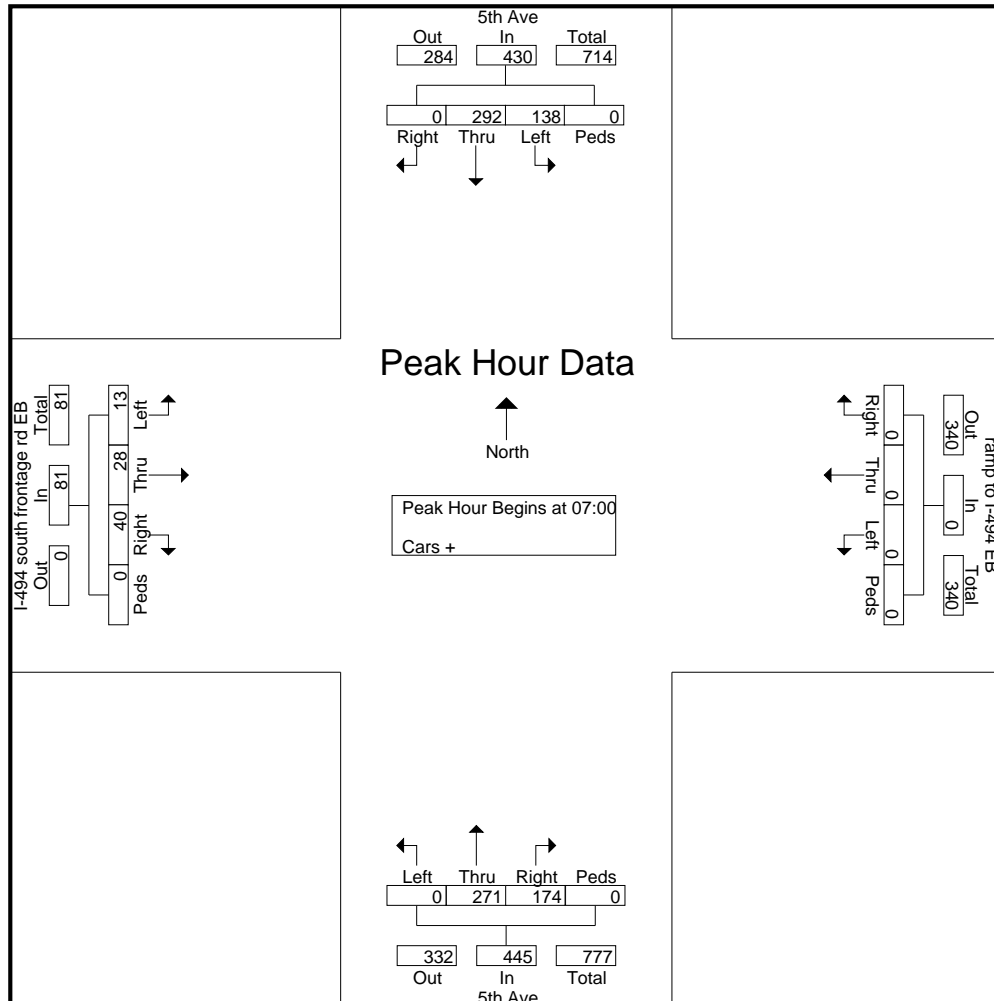

MN Dept of Transportation

TRAFFIC DATA COLLECTION - Metro

I-494 at 5th Ave, South Ramps
 Ref.Pt.: 065.106
 video RE
 TURN MOVEMENT COUNT

File Name : I-494 at 5th Ave South Ramps 2015
 Site Code :
 Start Date : 1/27/2015
 Page No : 3

Start Time	5th Ave Southbound					ramp to I-494 EB Westbound					5th Ave Northbound					I-494 south frontage rd EB Eastbound					Int. Total
	Left	Thru	Right	Peds	App. Total	Left	Thru	Right	Peds	App. Total	Left	Thru	Right	Peds	App. Total	Left	Thru	Right	Peds	App. Total	
Peak Hour Analysis From 15:00 to 17:45 - Peak 1 of 1																					
Peak Hour for Entire Intersection Begins at 16:45																					
16:45	23	87	0	0	110	0	0	0	0	0	0	83	53	0	136	14	9	24	0	47	293
17:00	37	85	0	0	122	0	0	0	0	0	0	73	76	0	149	11	16	26	0	53	324
17:15	44	81	0	0	125	0	0	0	0	0	0	67	50	0	117	12	6	21	0	39	281
17:30	28	69	0	0	97	0	0	0	0	0	0	64	50	0	114	9	16	24	0	49	260
Total Volume	132	322	0	0	454	0	0	0	0	0	0	287	229	0	516	46	47	95	0	188	1158
% App. Total	29.1	70.9	0	0		0	0	0	0		0	55.6	44.4	0		24.5	25	50.5	0		
PHF	.750	.925	.000	.000	.908	.000	.000	.000	.000	.000	.000	.864	.753	.000	.866	.821	.734	.913	.000	.887	.894

