



MINNESOTA DEPT OF TRANSPORTATION

TRAFFIC DATA COLLECTION - METRO

TH-101 AT VALLEY VIEW DR / KURVERS PT RD

File Name : TH-101 AT VALLEY VIEW RD 2009

Ref.Pt.: 014.312

Site Code : 00000000

JAMAR # T-2638 CAH

Start Date : 11/4/2009

TURN MOVEMENT COUNT

Page No : 1

Groups Printed- Cars & Trucks

Start Time	TH-101 Southbound				VALLEY VIEW DR. Westbound				TH-101 Northbound				KURVERS POINT RD. Eastbound				Int. Total	
	Left	Thru	Right	Peds	Left	Thru	Right	Peds	Left	Thru	Right	Peds	Left	Thru	Right	Peds		
06:00	1	12	0	1	1	0	1	0	0	19	0	0	0	1	1	0	0	37
06:15	1	26	0	0	2	0	1	0	1	18	3	0	2	0	0	0	0	54
06:30	2	39	0	0	5	0	3	2	0	45	3	1	0	1	0	0	0	101
06:45	3	64	1	0	6	0	2	0	1	39	3	0	3	0	4	2	2	128
Total	7	141	1	1	14	0	7	2	2	121	9	1	5	2	5	2	2	320
07:00	2	47	0	0	8	0	2	0	1	65	10	0	4	0	0	0	0	139
07:15	6	53	0	1	3	0	5	0	2	79	13	0	6	0	2	0	0	170
07:30	9	81	2	0	6	0	6	1	0	106	8	0	5	1	1	0	0	226
07:45	7	79	0	0	6	0	3	1	1	90	12	0	5	0	1	1	1	206
Total	24	260	2	1	23	0	16	2	4	340	43	0	20	1	4	1	1	741
08:00	3	76	1	0	9	0	2	0	0	72	13	0	4	2	3	0	0	185
08:15	2	64	0	0	4	0	2	0	0	86	5	0	1	1	2	0	0	167
08:30	2	83	1	0	7	2	3	0	2	73	6	0	3	2	3	0	0	187
08:45	5	74	0	1	9	1	1	0	3	46	6	0	4	1	2	0	0	153
Total	12	297	2	1	29	3	8	0	5	277	30	0	12	6	10	0	0	692
*** BREAK ***																		
15:00	2	92	5	0	10	0	5	0	2	72	9	0	1	1	1	0	0	200
15:15	1	81	1	0	12	0	4	0	0	93	17	0	1	1	1	0	0	212
15:30	2	86	3	0	8	0	4	0	2	86	19	0	2	0	2	0	0	214
15:45	6	89	1	0	9	0	2	0	1	52	12	0	2	0	2	0	0	176
Total	11	348	10	0	39	0	15	0	5	303	57	0	6	2	6	0	0	802
16:00	1	85	0	1	12	1	6	0	5	95	11	0	0	0	1	0	0	218
16:15	7	78	3	0	11	1	9	0	2	99	18	0	2	0	2	0	0	232
16:30	8	80	3	1	14	1	5	0	3	80	21	0	1	1	3	0	0	221
16:45	5	102	2	0	9	0	5	0	2	86	15	0	0	1	3	0	0	230
Total	21	345	8	2	46	3	25	0	12	360	65	0	3	2	9	0	0	901
17:00	4	108	2	0	10	1	7	0	3	110	10	0	0	0	1	2	0	258
17:15	3	109	2	0	8	0	4	0	3	97	17	0	1	0	0	0	0	244
17:30	7	120	5	0	10	0	7	0	4	100	16	0	2	3	1	0	0	275
17:45	6	90	2	0	16	1	2	0	2	79	14	0	0	0	2	0	0	214
Total	20	427	11	0	44	2	20	0	12	386	57	0	3	3	4	2	0	991
Grand Total	95	1818	34	5	195	8	91	4	40	1787	261	1	49	16	38	5	0	4447
Apprch %	4.9	93.1	1.7	0.3	65.4	2.7	30.5	1.3	1.9	85.5	12.5	0	45.4	14.8	35.2	4.6	0	
Total %	2.1	40.9	0.8	0.1	4.4	0.2	2	0.1	0.9	40.2	5.9	0	1.1	0.4	0.9	0.1	0	



MINNESOTA DEPT OF TRANSPORTATION

TRAFFIC DATA COLLECTION - METRO

TH-101 AT VALLEY VIEW DR / KURVERS PT RD
 Ref.Pt.: 014.312
 JAMAR # T-2638 CAH
 TURN MOVEMENT COUNT

File Name : TH-101 AT VALLEY VIEW RD 2009
 Site Code : 00000000
 Start Date : 11/4/2009
 Page No : 2

Start Time	TH-101 Southbound					VALLEY VIEW DR. Westbound					TH-101 Northbound					KURVERS POINT RD. Eastbound					Int. Total
	Left	Thru	Right	Peds	App. Total	Left	Thru	Right	Peds	App. Total	Left	Thru	Right	Peds	App. Total	Left	Thru	Right	Peds	App. Total	
Peak Hour Analysis From 06:00 to 08:45 - Peak 1 of 1																					
Peak Hour for Entire Intersection Begins at 07:15																					
07:15	6	53	0	1	60	3	0	5	0	8	2	79	13	0	94	6	0	2	0	8	170
07:30	9	81	2	0	92	6	0	6	1	13	0	106	8	0	114	5	1	1	0	7	226
07:45	7	79	0	0	86	6	0	3	1	10	1	90	12	0	103	5	0	1	1	7	206
08:00	3	76	1	0	80	9	0	2	0	11	0	72	13	0	85	4	2	3	0	9	185
Total Volume	25	289	3	1	318	24	0	16	2	42	3	347	46	0	396	20	3	7	1	31	787
% App. Total																					
PHF	.694	.892	.375	.250	.864	.667	.000	.667	.500	.808	.375	.818	.885	.000	.868	.833	.375	.583	.250	.861	.871

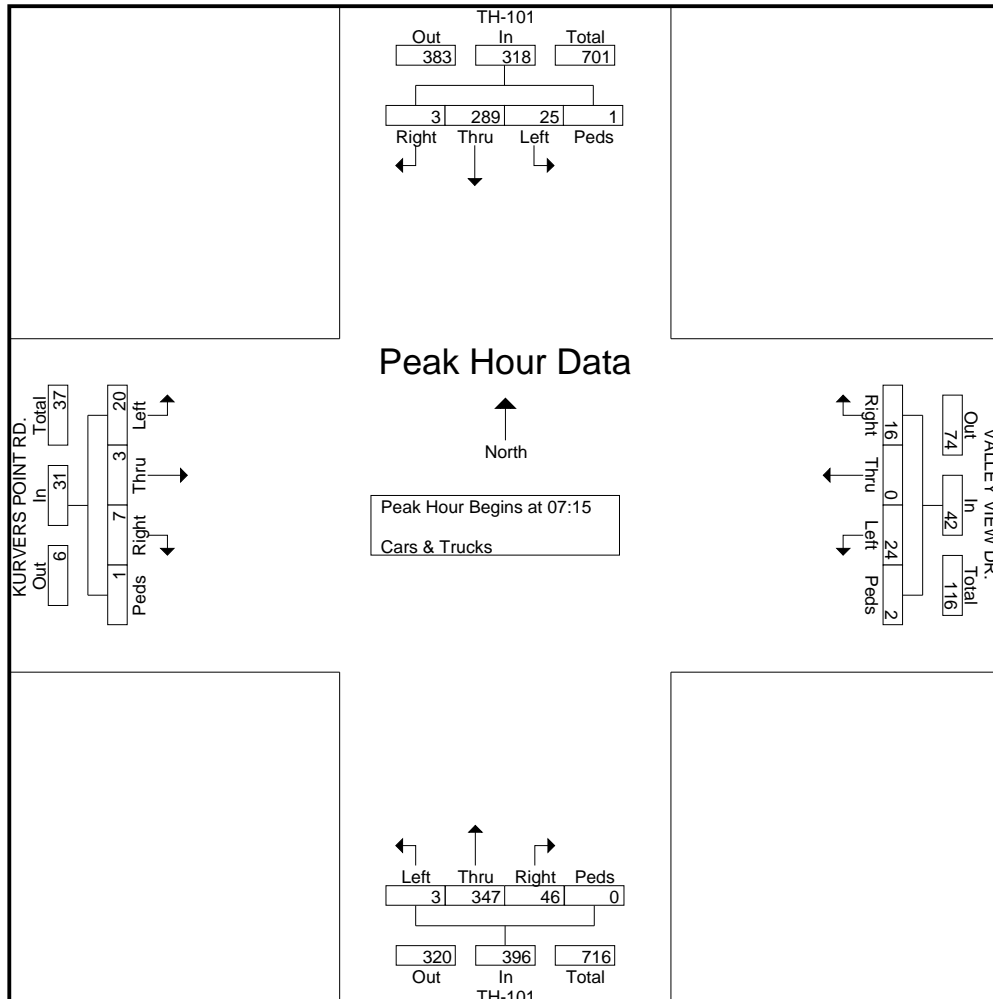



MINNESOTA DEPT OF TRANSPORTATION

TRAFFIC DATA COLLECTION - METRO

TH-101 AT VALLEY VIEW DR / KURVERS PT RD
 Ref.Pt.: 014.312
 JAMAR # T-2638 CAH
 TURN MOVEMENT COUNT

File Name : TH-101 AT VALLEY VIEW RD 2009
 Site Code : 00000000
 Start Date : 11/4/2009
 Page No : 3

Start Time	TH-101 Southbound					VALLEY VIEW DR. Westbound					TH-101 Northbound					KURVERS POINT RD. Eastbound					Int. Total
	Left	Thru	Right	Peds	App. Total	Left	Thru	Right	Peds	App. Total	Left	Thru	Right	Peds	App. Total	Left	Thru	Right	Peds	App. Total	
Peak Hour Analysis From 15:00 to 17:45 - Peak 1 of 1																					
Peak Hour for Entire Intersection Begins at 16:45																					
16:45	5	102	2	0	109	9	0	5	0	14	2	86	15	0	103	0	1	3	0	4	230
17:00	4	108	2	0	114	10	1	7	0	18	3	110	10	0	123	0	0	1	2	3	258
17:15	3	109	2	0	114	8	0	4	0	12	3	97	17	0	117	1	0	0	0	1	244
17:30	7	120	5	0	132	10	0	7	0	17	4	100	16	0	120	2	3	1	0	6	275
Total Volume	19	439	11	0	469	37	1	23	0	61	12	393	58	0	463	3	4	5	2	14	1007
% App. Total																					
PHF	.679	.915	.550	.000	.888	.925	.250	.821	.000	.847	.750	.893	.853	.000	.941	.375	.333	.417	.250	.583	.915

