

TH 3 at TH 246
 Carto Measure:12.272
 Data By: Short Elliott Hendrickson, Inc.
 TURN MOVEMENT COUNT

File Name : TH 3 & TH 246 2019
 Site Code : 1e
 Start Date : 10/9/2019
 Page No : 1

Groups Printed- Vehicles - Trucks

Start Time	TH 3 Southbound					TH 246 Westbound					TH 3 Northbound					TH 246 Eastbound					Int. Total
	Right	Thru	Left	Peds	App. Total	Right	Thru	Left	Peds	App. Total	Right	Thru	Left	Peds	App. Total	Right	Thru	Left	Peds	App. Total	
06:00 AM	1	43	8	0	52	26	3	3	0	32	6	99	0	0	105	0	0	2	0	2	191
06:15 AM	2	62	15	0	79	30	5	11	0	46	5	110	0	0	115	0	0	1	0	1	241
06:30 AM	6	83	13	0	102	37	1	9	0	47	3	133	0	0	136	0	0	3	0	3	288
06:45 AM	4	99	24	0	127	38	2	14	0	54	5	116	0	0	121	0	1	1	0	2	304
Total	13	287	60	0	360	131	11	37	0	179	19	458	0	0	477	0	1	7	0	8	1024
07:00 AM	2	99	42	0	143	31	2	15	0	48	17	132	0	0	149	0	3	2	0	5	345
07:15 AM	4	145	55	1	205	48	3	15	0	66	13	144	0	0	157	0	2	3	0	5	433
07:30 AM	2	160	33	0	195	34	2	14	1	51	10	151	0	0	161	0	2	3	0	5	412
07:45 AM	15	154	39	0	208	37	7	19	0	63	16	153	0	0	169	0	2	9	0	11	451
Total	23	558	169	1	751	150	14	63	1	228	56	580	0	0	636	0	9	17	0	26	1641
08:00 AM	6	132	24	0	162	36	4	10	0	50	17	145	1	0	163	0	0	3	0	3	378
08:15 AM	5	144	38	0	187	53	7	20	0	80	14	142	0	0	156	0	5	2	0	7	430
08:30 AM	7	144	77	0	228	49	5	19	0	73	20	168	0	0	188	0	5	3	0	8	497
08:45 AM	6	141	37	1	185	57	7	21	1	86	23	203	0	0	226	0	3	3	0	6	503
Total	24	561	176	1	762	195	23	70	1	289	74	658	1	0	733	0	13	11	0	24	1808
09:00 AM	7	154	42	0	203	46	9	12	0	67	22	126	0	0	148	2	3	8	0	13	431
09:15 AM	11	133	37	0	181	45	5	24	0	74	17	149	0	0	166	1	5	4	0	10	431
09:30 AM	5	122	20	0	147	34	3	22	0	59	13	139	2	0	154	0	7	6	0	13	373
09:45 AM	4	154	26	0	184	30	3	20	0	53	26	108	0	0	134	0	4	4	0	8	379
Total	27	563	125	0	715	155	20	78	0	253	78	522	2	0	602	3	19	22	0	44	1614
10:00 AM	12	143	22	0	177	30	3	12	0	45	22	115	1	0	138	0	4	5	0	9	369
10:15 AM	3	132	18	1	154	31	3	22	0	56	21	117	2	0	140	0	2	6	0	8	358
10:30 AM	7	102	28	0	137	33	12	31	0	76	17	117	0	0	134	3	4	6	0	13	360
10:45 AM	7	112	29	0	148	24	6	26	0	56	15	130	1	0	146	2	5	9	0	16	366
Total	29	489	97	1	616	118	24	91	0	233	75	479	4	0	558	5	15	26	0	46	1453
11:00 AM	12	116	33	0	161	46	6	30	0	82	18	109	2	0	129	4	4	7	0	15	387
11:15 AM	17	142	31	0	190	30	6	23	0	59	19	134	1	0	154	1	5	11	0	17	420
11:30 AM	15	106	31	1	153	33	11	26	0	70	25	103	1	0	129	4	7	12	0	23	375
11:45 AM	23	147	25	0	195	28	17	35	0	80	29	166	0	0	195	2	16	9	1	28	498
Total	67	511	120	1	699	137	40	114	0	291	91	512	4	0	607	11	32	39	1	83	1680
12:00 PM	18	165	34	0	217	43	9	27	0	79	17	123	2	0	142	6	11	19	0	36	474
12:15 PM	10	120	25	1	156	38	10	19	0	67	12	134	2	0	148	3	14	18	0	35	406
12:30 PM	20	146	31	1	198	32	18	19	0	69	17	136	6	0	159	1	13	15	0	29	455
12:45 PM	13	158	34	1	206	43	13	27	0	83	23	108	2	0	133	4	9	13	0	26	448
Total	61	589	124	3	777	156	50	92	0	298	69	501	12	0	582	14	47	65	0	126	1783
01:00 PM	16	130	31	0	177	41	9	28	0	78	16	134	4	0	154	2	9	14	0	25	434
01:15 PM	8	135	25	0	168	32	7	28	2	69	20	137	2	0	159	1	9	21	0	31	427
01:30 PM	13	134	29	0	176	43	10	27	1	81	19	146	2	0	167	0	10	12	0	22	446
01:45 PM	13	152	32	1	198	40	6	21	0	67	21	145	1	0	167	1	7	21	0	29	461
Total	50	551	117	1	719	156	32	104	3	295	76	562	9	0	647	4	35	68	0	107	1768
02:00 PM	6	147	31	0	184	41	8	24	0	73	19	149	0	0	168	1	7	17	0	25	450
02:15 PM	6	187	33	0	226	32	7	18	0	57	16	140	2	0	158	3	10	4	0	17	458
02:30 PM	8	212	44	0	264	38	6	16	0	60	16	162	1	0	179	2	8	8	0	18	521
02:45 PM	7	186	61	1	255	37	8	27	0	72	23	155	4	0	182	1	11	7	0	19	528
Total	27	732	169	1	929	148	29	85	0	262	74	606	7	0	687	7	36	36	0	79	1957
03:00 PM	14	171	33	1	219	47	14	25	0	86	28	206	1	0	235	1	11	10	0	22	562
03:15 PM	10	192	48	0	250	41	6	33	0	80	16	153	2	0	171	2	11	12	0	25	526
03:30 PM	14	202	57	1	274	46	9	28	0	83	17	186	3	0	206	0	11	20	0	31	594

TH 3 at TH 246
 Carto Measure:12.272
 Data By: Short Elliott Hendrickson, Inc.
 TURN MOVEMENT COUNT

File Name : TH 3 & TH 246 2019
 Site Code : 1e
 Start Date : 10/9/2019
 Page No : 2

Groups Printed- Vehicles - Trucks

Start Time	TH 3 Southbound					TH 246 Westbound					TH 3 Northbound					TH 246 Eastbound					Int. Total
	Right	Thru	Left	Peds	App. Total	Right	Thru	Left	Peds	App. Total	Right	Thru	Left	Peds	App. Total	Right	Thru	Left	Peds	App. Total	
03:45 PM	13	171	63	2	249	36	15	41	0	92	17	170	3	0	190	2	7	8	0	17	548
Total	51	736	201	4	992	170	44	127	0	341	78	715	9	0	802	5	40	50	0	95	2230
04:00 PM	14	216	50	0	280	33	11	40	0	84	18	200	1	0	219	3	9	6	0	18	601
04:15 PM	11	228	50	1	290	47	2	28	0	77	27	177	2	0	206	0	16	15	0	31	604
04:30 PM	15	248	59	30	352	39	11	20	0	70	25	171	3	2	201	1	11	20	1	33	656
04:45 PM	15	224	68	0	307	43	9	30	0	82	26	187	3	0	216	3	14	25	0	42	647
Total	55	916	227	31	1229	162	33	118	0	313	96	735	9	2	842	7	50	66	1	124	2508
05:00 PM	22	256	58	1	337	45	5	33	1	84	25	230	1	0	256	2	11	17	1	31	708
05:15 PM	20	236	70	1	327	49	11	25	0	85	18	183	5	0	206	2	7	19	0	28	646
05:30 PM	19	193	46	0	258	56	16	35	0	107	17	169	4	0	190	1	11	17	0	29	584
05:45 PM	16	162	40	3	221	38	8	25	0	71	19	152	3	0	174	1	8	16	0	25	491
Total	77	847	214	5	1143	188	40	118	1	347	79	734	13	0	826	6	37	69	1	113	2429
06:00 PM	9	192	36	1	238	33	8	29	0	70	20	139	3	0	162	2	8	10	0	20	490
06:15 PM	20	172	28	0	220	28	14	22	0	64	16	127	7	0	150	2	18	17	0	37	471
06:30 PM	8	154	30	0	192	29	8	17	0	54	30	145	1	0	176	1	15	15	0	31	453
06:45 PM	9	135	48	0	192	35	8	27	0	70	33	136	2	0	171	1	6	20	0	27	460
Total	46	653	142	1	842	125	38	95	0	258	99	547	13	0	659	6	47	62	0	115	1874
Grand Total	550	7993	1941	50	10534	1991	398	1192	6	3587	964	7609	83	2	8658	68	381	538	3	990	23769
Apprch %	5.2	75.9	18.4	0.5		55.5	11.1	33.2	0.2		11.1	87.9	1	0		6.9	38.5	54.3	0.3		
Total %	2.3	33.6	8.2	0.2	44.3	8.4	1.7	5	0	15.1	4.1	32	0.3	0	36.4	0.3	1.6	2.3	0	4.2	
Vehicles	545	7369	1876			1901		1157				6971									22234
% Vehicles	99.1	92.2	96.7	96	93.4	95.5	94	97.1	100	95.8	96.6	91.6	100	100	92.2	100	99.2	97.4	33.3	98.1	93.5
Trucks	5	624	65	2	696	90	24	35	0	149	33	638	0	0	671	0	3	14	2	19	1535
% Trucks	0.9	7.8	3.3	4	6.6	4.5	6	2.9	0	4.2	3.4	8.4	0	0	7.8	0	0.8	2.6	66.7	1.9	6.5

Start Time	TH 3 Southbound					TH 246 Westbound					TH 3 Northbound					TH 246 Eastbound					Int. Total
	Right	Thru	Left	Peds	App. Total	Right	Thru	Left	Peds	App. Total	Right	Thru	Left	Peds	App. Total	Right	Thru	Left	Peds	App. Total	
Peak Hour Analysis From 06:00 AM to 08:45 AM - Peak 1 of 1																					
Peak Hour for Entire Intersection Begins at 08:00 AM																					
08:00 AM	6	132	24	0	162	36	4	10	0	50	17	145	1	0	163	0	0	3	0	3	378
08:15 AM	5	144	38	0	187	53	7	20	0	80	14	142	0	0	156	0	5	2	0	7	430
08:30 AM	7	144	77	0	228	49	5	19	0	73	20	168	0	0	188	0	5	3	0	8	497
08:45 AM	6	141	37	1	185	57	7	21	1	86	23	203	0	0	226	0	3	3	0	6	503
Total Volume	24	561	176	1	762	195	23	70	1	289	74	658	1	0	733	0	13	11	0	24	1808
% App. Total	3.1	73.6	23.1	0.1		67.5	8	24.2	0.3		10.1	89.8	0.1	0		0	54.2	45.8	0		
PHF	.857	.974	.571	.250	.836	.855	.821	.833	.250	.840	.804	.810	.250	.000	.811	.000	.650	.917	.000	.750	.899

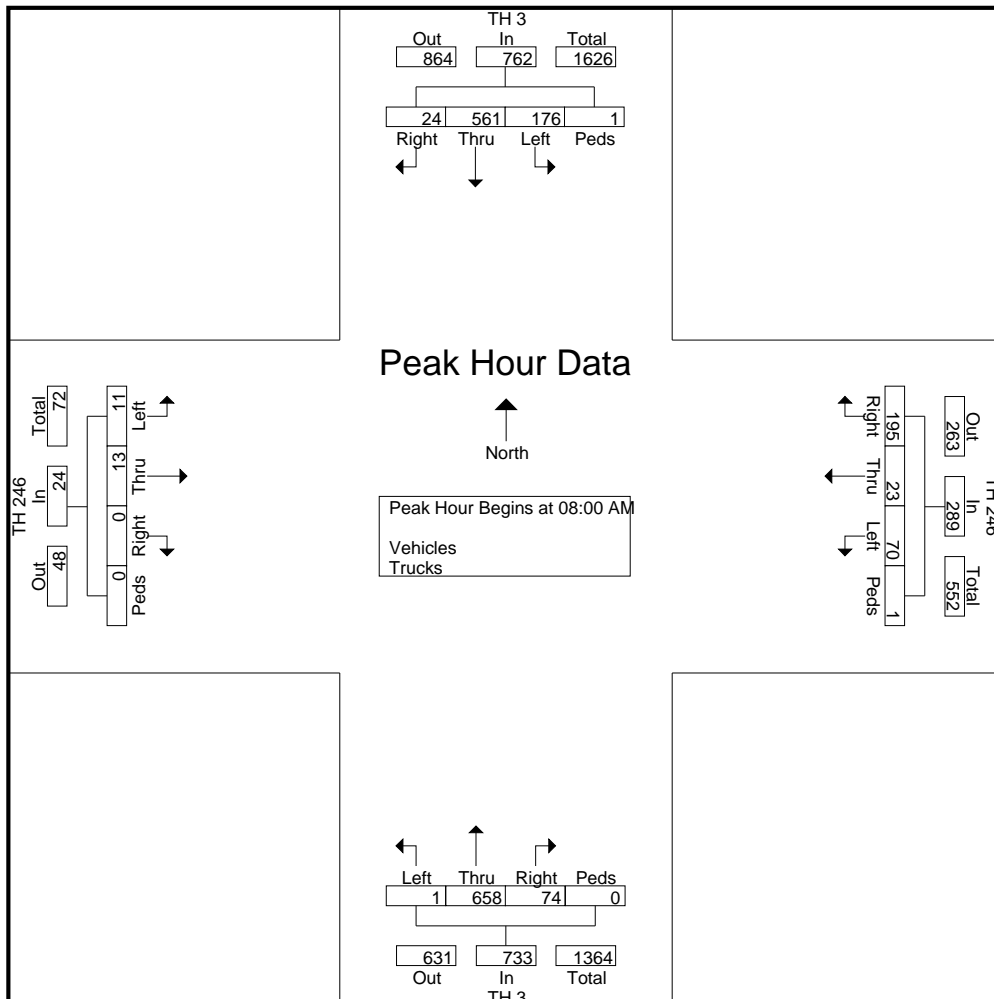

TH 3 at TH 246
 Carto Measure:12.272
 Data By: Short Elliott Hendrickson, Inc.
 TURN MOVEMENT COUNT

File Name : TH 3 & TH 246 2019
 Site Code : 1e
 Start Date : 10/9/2019
 Page No : 4

Start Time	TH 3 Southbound					TH 246 Westbound					TH 3 Northbound					TH 246 Eastbound					Int. Total
	Right	Thru	Left	Peds	App. Total	Right	Thru	Left	Peds	App. Total	Right	Thru	Left	Peds	App. Total	Right	Thru	Left	Peds	App. Total	

Peak Hour Analysis From 11:00 AM to 12:45 PM - Peak 1 of 1
 Peak Hour for Entire Intersection Begins at 11:45 AM

11:45 AM	23	147	25	0	195	28	17	35	0	80	29	166	0	0	195	2	16	9	1	28	498
12:00 PM	18	165	34	0	217	43	9	27	0	79	17	123	2	0	142	6	11	19	0	36	474
12:15 PM	10	120	25	1	156	38	10	19	0	67	12	134	2	0	148	3	14	18	0	35	406
12:30 PM	20	146	31	1	198	32	18	19	0	69	17	136	6	0	159	1	13	15	0	29	455
Total Volume	71	578	115	2	766	141	54	100	0	295	75	559	10	0	644	12	54	61	1	128	1833
% App. Total	9.3	75.5	15	0.3		47.8	18.3	33.9	0		11.6	86.8	1.6	0		9.4	42.2	47.7	0.8		
PHF	.772	.876	.846	.500	.882	.820	.750	.714	.000	.922	.647	.842	.417	.000	.826	.500	.844	.803	.250	.889	.920

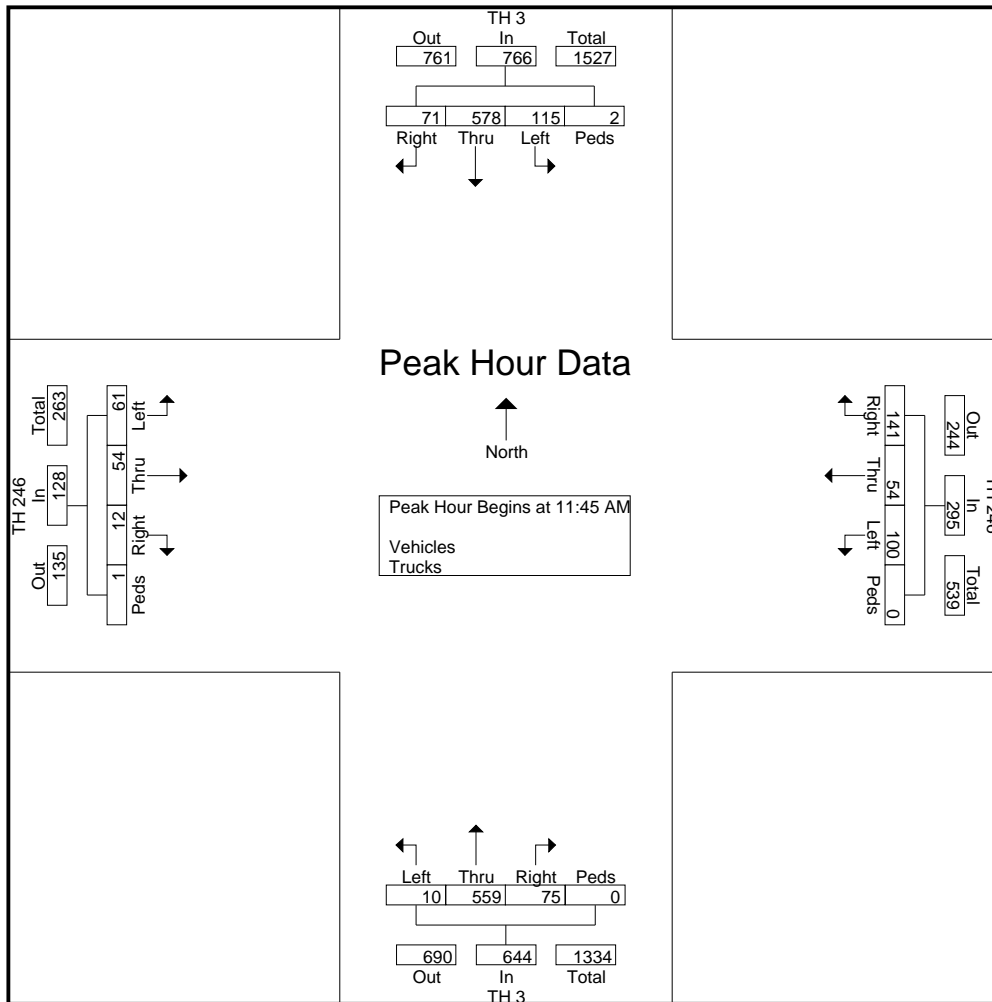

TH 3 at TH 246
 Carto Measure:12.272
 Data By: Short Elliott Hendrickson, Inc.
 TURN MOVEMENT COUNT

File Name : TH 3 & TH 246 2019
 Site Code : 1e
 Start Date : 10/9/2019
 Page No : 5

Start Time	TH 3 Southbound					TH 246 Westbound					TH 3 Northbound					TH 246 Eastbound					Int. Total
	Right	Thru	Left	Peds	App. Total	Right	Thru	Left	Peds	App. Total	Right	Thru	Left	Peds	App. Total	Right	Thru	Left	Peds	App. Total	
Peak Hour Analysis From 03:00 PM to 05:45 PM - Peak 1 of 1																					
Peak Hour for Entire Intersection Begins at 04:30 PM																					
04:30 PM	15	248	59	30	352	39	11	20	0	70	25	171	3	2	201	1	11	20	1	33	656
04:45 PM	15	224	68	0	307	43	9	30	0	82	26	187	3	0	216	3	14	25	0	42	647
05:00 PM	22	256	58	1	337	45	5	33	1	84	25	230	1	0	256	2	11	17	1	31	708
05:15 PM	20	236	70	1	327	49	11	25	0	85	18	183	5	0	206	2	7	19	0	28	646
Total Volume	72	964	255	32	1323	176	36	108	1	321	94	771	12	2	879	8	43	81	2	134	2657
% App. Total	5.4	72.9	19.3	2.4		54.8	11.2	33.6	0.3		10.7	87.7	1.4	0.2		6	32.1	60.4	1.5		
PHF	.818	.941	.911	.267	.940	.898	.818	.818	.250	.944	.904	.838	.600	.250	.858	.667	.768	.810	.500	.798	.938

