

TH 3 at TH 19 N Jct  
 Carto Measure: 12.924  
 Data By: Short Elliott Hendrickson, Inc.  
 TURN MOVEMENT COUNT

File Name : TH 3 & TH 19 N Jct 2019  
 Site Code : 1g  
 Start Date : 10/9/2019  
 Page No : 1

Groups Printed- Vehicles - Trucks

Start Time	TH 3 Southbound					TH 19 Westbound					TH 3 Northbound					2nd St Eastbound					Int. Total
	Right	Thru	Left	Peds	App. Total	Right	Thru	Left	Peds	App. Total	Right	Thru	Left	Peds	App. Total	Right	Thru	Left	Peds	App. Total	
06:00 AM	1	55	6	0	62	14	2	12	0	28	11	107	2	0	120	1	1	3	0	5	215
06:15 AM	1	79	12	0	92	19	5	12	0	36	19	116	0	0	135	1	0	3	0	4	267
06:30 AM	2	100	18	1	121	25	2	22	0	49	20	141	0	0	161	7	6	3	0	16	347
06:45 AM	1	104	17	3	125	29	5	23	0	57	18	120	5	0	143	5	2	1	0	8	333
Total	5	338	53	4	400	87	14	69	0	170	68	484	7	0	559	14	9	10	0	33	1162
07:00 AM	1	102	19	0	122	31	2	24	0	57	23	127	2	0	152	11	9	9	0	29	360
07:15 AM	2	158	22	2	184	46	7	17	1	71	24	162	6	1	193	13	4	5	0	22	470
07:30 AM	4	152	25	0	181	34	3	21	0	58	28	146	3	0	177	14	5	15	0	34	450
07:45 AM	6	169	28	0	203	42	8	20	0	70	56	128	2	0	186	10	13	2	0	25	484
Total	13	581	94	2	690	153	20	82	1	256	131	563	13	1	708	48	31	31	0	110	1764
08:00 AM	9	140	36	1	186	32	10	20	1	63	35	124	4	1	164	12	3	4	1	20	433
08:15 AM	2	161	24	2	189	27	8	22	0	57	36	130	3	1	170	20	18	5	0	43	459
08:30 AM	3	147	36	3	189	28	7	32	1	68	35	147	8	1	191	19	6	4	0	29	477
08:45 AM	6	151	30	0	187	48	14	22	1	85	39	155	9	1	204	11	14	4	0	29	505
Total	20	599	126	6	751	135	39	96	3	273	145	556	24	4	729	62	41	17	1	121	1874
09:00 AM	6	169	27	1	203	34	10	24	1	69	28	135	9	0	172	16	11	6	0	33	477
09:15 AM	8	145	32	1	186	19	5	19	0	43	25	119	3	0	147	12	10	5	0	27	403
09:30 AM	7	104	21	4	136	25	11	13	0	49	27	106	5	0	138	11	14	2	0	27	350
09:45 AM	2	123	27	1	153	27	7	31	0	65	32	91	5	1	129	12	10	7	0	29	376
Total	23	541	107	7	678	105	33	87	1	226	112	451	22	1	586	51	45	20	0	116	1606
10:00 AM	4	95	15	1	115	20	3	23	1	47	29	91	4	0	124	10	9	2	0	21	307
10:15 AM	1	112	12	1	126	24	8	21	3	56	21	114	3	1	139	12	8	1	0	21	342
10:30 AM	1	93	23	1	118	22	5	22	0	49	27	104	6	1	138	5	7	3	0	15	320
10:45 AM	3	107	28	2	140	17	11	26	0	54	25	123	2	0	150	6	10	4	0	20	364
Total	9	407	78	5	499	83	27	92	4	206	102	432	15	2	551	33	34	10	0	77	1333
11:00 AM	4	109	21	1	135	17	11	29	2	59	15	97	7	0	119	11	4	5	0	20	333
11:15 AM	2	105	16	0	123	22	7	27	0	56	20	111	7	0	138	13	9	1	1	24	341
11:30 AM	5	128	21	1	155	25	8	31	0	64	16	102	9	0	127	17	11	4	0	32	378
11:45 AM	6	139	28	2	175	20	12	36	0	68	25	115	7	3	150	14	8	4	0	26	419
Total	17	481	86	4	588	84	38	123	2	247	76	425	30	3	534	55	32	14	1	102	1471
12:00 PM	6	136	27	1	170	26	11	29	1	67	30	111	4	0	145	14	12	5	0	31	413
12:15 PM	4	105	30	2	141	24	10	31	2	67	19	125	7	2	153	16	15	6	0	37	398
12:30 PM	2	121	20	2	145	29	10	23	0	62	23	124	4	3	154	9	8	7	0	24	385
12:45 PM	9	125	18	1	153	33	7	22	1	63	35	109	13	2	159	10	16	10	0	36	411
Total	21	487	95	6	609	112	38	105	4	259	107	469	28	7	611	49	51	28	0	128	1607
01:00 PM	3	118	26	2	149	29	9	26	0	64	33	111	8	2	154	5	14	1	0	20	387
01:15 PM	2	127	24	1	154	29	4	38	0	71	22	123	7	0	152	9	10	4	0	23	400
01:30 PM	8	122	23	3	156	32	12	29	1	74	30	121	2	1	154	8	7	4	0	19	403
01:45 PM	1	133	22	1	157	29	9	34	1	73	16	140	6	4	166	8	4	6	0	18	414
Total	14	500	95	7	616	119	34	127	2	282	101	495	23	7	626	30	35	15	0	80	1604
02:00 PM	6	130	31	0	167	28	5	30	0	63	31	148	6	3	188	15	8	2	0	25	443
02:15 PM	2	142	23	1	168	35	12	30	1	78	29	121	6	2	158	15	9	6	0	30	434
02:30 PM	4	223	31	3	261	30	8	45	0	83	21	153	5	3	182	11	9	8	0	28	554
02:45 PM	5	167	35	1	208	45	5	34	0	84	15	159	6	2	182	10	14	6	0	30	504
Total	17	662	120	5	804	138	30	139	1	308	96	581	23	10	710	51	40	22	0	113	1935
03:00 PM	6	164	37	3	210	32	7	38	3	80	30	180	12	0	222	5	10	8	0	23	535
03:15 PM	3	198	48	1	250	31	13	36	1	81	22	146	8	2	178	12	12	2	0	26	535
03:30 PM	1	185	32	1	219	47	8	32	0	87	34	172	10	2	218	7	12	6	0	25	549

TH 3 at TH 19 N Jct  
 Carto Measure: 12.924  
 Data By: Short Elliott Hendrickson, Inc.  
 TURN MOVEMENT COUNT

File Name : TH 3 & TH 19 N Jct 2019  
 Site Code : 1g  
 Start Date : 10/9/2019  
 Page No : 2

Groups Printed- Vehicles - Trucks

Start Time	TH 3 Southbound					TH 19 Westbound					TH 3 Northbound					2nd St Eastbound					Int. Total
	Right	Thru	Left	Peds	App. Total	Right	Thru	Left	Peds	App. Total	Right	Thru	Left	Peds	App. Total	Right	Thru	Left	Peds	App. Total	
03:45 PM	4	200	39	3	246	36	4	28	0	68	29	154	10	1	194	9	14	6	0	29	537
Total	14	747	156	8	925	146	32	134	4	316	115	652	40	5	812	33	48	22	0	103	2156
04:00 PM	3	183	26	0	212	40	10	43	0	93	28	160	12	0	200	16	10	4	0	30	535
04:15 PM	2	255	19	3	279	21	6	44	2	73	13	182	5	0	200	15	10	7	0	32	584
04:30 PM	4	218	40	3	265	46	14	57	0	117	33	172	15	0	220	13	8	6	0	27	629
04:45 PM	3	240	41	1	285	53	24	43	0	120	35	148	8	2	193	14	22	6	0	42	640
Total	12	896	126	7	1041	160	54	187	2	403	109	662	40	2	813	58	50	23	0	131	2388
05:00 PM	5	218	35	3	261	53	21	64	1	139	30	229	10	0	269	18	19	4	0	41	710
05:15 PM	7	206	42	9	264	56	14	48	0	118	29	195	20	5	249	7	22	6	0	35	666
05:30 PM	3	184	40	4	231	32	14	43	0	89	20	198	11	2	231	6	18	5	0	29	580
05:45 PM	4	175	42	4	225	51	16	26	0	93	29	159	6	1	195	19	17	5	0	41	554
Total	19	783	159	20	981	192	65	181	1	439	108	781	47	8	944	50	76	20	0	146	2510
06:00 PM	3	144	36	4	187	23	12	29	0	64	23	135	3	4	165	25	19	3	0	47	463
06:15 PM	7	150	33	1	191	28	9	35	2	74	23	128	8	7	166	15	12	2	0	29	460
06:30 PM	9	162	36	8	215	23	9	17	2	51	14	136	8	0	158	13	3	0	0	16	440
06:45 PM	2	142	26	2	172	32	9	19	0	60	28	151	10	3	192	14	8	6	0	28	452
Total	21	598	131	15	765	106	39	100	4	249	88	550	29	14	681	67	42	11	0	120	1815
Grand Total	205	7620	1426	96	9347	1620	463	1522	29	3634	1358	7101	341	64	8864	601	534	243	2	1380	23225
Apprch %	2.2	81.5	15.3	1		44.6	12.7	41.9	0.8		15.3	80.1	3.8	0.7		43.6	38.7	17.6	0.1		
Total %	0.9	32.8	6.1	0.4	40.2	7	2	6.6	0.1	15.6	5.8	30.6	1.5	0.3	38.2	2.6	2.3	1	0	5.9	
Vehicles	199	7033	1394			1577		1372			1212	6512									21497
% Vehicles	97.1	92.3	97.8	77.1	93.1	97.3	93.5	90.1	96.6	93.8	89.2	91.7	93.3	90.6	91.4	91.7	94.2	95.5	50	93.3	92.6
Trucks	6	587	32	22	647	43	30	150	1	224	146	589	23	6	764	50	31	11	1	93	1728
% Trucks	2.9	7.7	2.2	22.9	6.9	2.7	6.5	9.9	3.4	6.2	10.8	8.3	6.7	9.4	8.6	8.3	5.8	4.5	50	6.7	7.4

TH 3 at TH 19 N Jct  
 Carto Measure: 12.924  
 Data By: Short Elliott Hendrickson, Inc.  
 TURN MOVEMENT COUNT

File Name : TH 3 & TH 19 N Jct 2019  
 Site Code : 1g  
 Start Date : 10/9/2019  
 Page No : 3

Start Time	TH 3 Southbound					TH 19 Westbound					TH 3 Northbound					2nd St Eastbound					Int. Total
	Right	Thru	Left	Peds	App. Total	Right	Thru	Left	Peds	App. Total	Right	Thru	Left	Peds	App. Total	Right	Thru	Left	Peds	App. Total	
Peak Hour Analysis From 06:00 AM to 08:45 AM - Peak 1 of 1																					
Peak Hour for Entire Intersection Begins at 08:00 AM																					
08:00 AM	9	140	36	1	186	32	10	20	1	63	35	124	4	1	164	12	3	4	1	20	433
08:15 AM	2	161	24	2	189	27	8	22	0	57	36	130	3	1	170	20	18	5	0	43	459
08:30 AM	3	147	36	3	189	28	7	32	1	68	35	147	8	1	191	19	6	4	0	29	477
08:45 AM	6	151	30	0	187	48	14	22	1	85	39	155	9	1	204	11	14	4	0	29	505
Total Volume	20	599	126	6	751	135	39	96	3	273	145	556	24	4	729	62	41	17	1	121	1874
% App. Total	2.7	79.8	16.8	0.8		49.5	14.3	35.2	1.1		19.9	76.3	3.3	0.5		51.2	33.9	14	0.8		
PHF	.556	.930	.875	.500	.993	.703	.696	.750	.750	.803	.929	.897	.667	1.00	.893	.775	.569	.850	.250	.703	.928

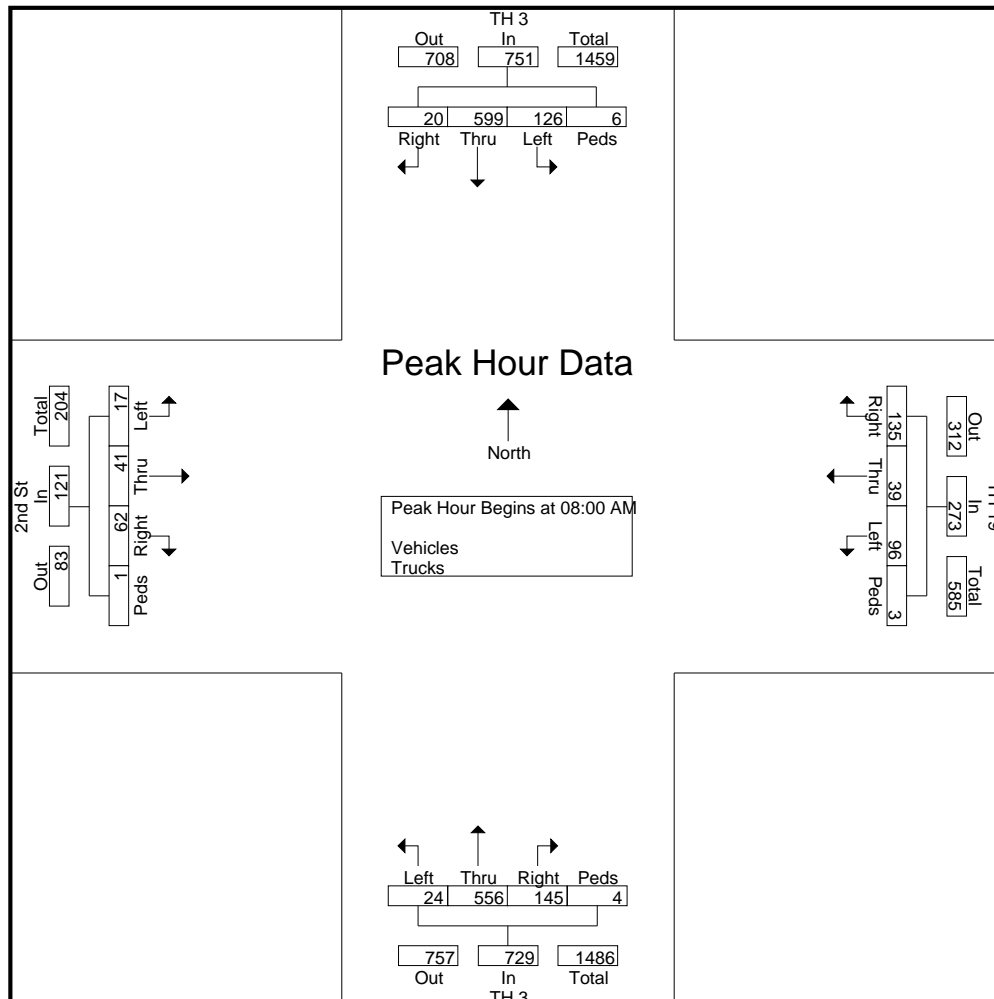

TH 3 at TH 19 N Jct  
 Carto Measure: 12.924  
 Data By: Short Elliott Hendrickson, Inc.  
 TURN MOVEMENT COUNT

File Name : TH 3 & TH 19 N Jct 2019  
 Site Code : 1g  
 Start Date : 10/9/2019  
 Page No : 4

Start Time	TH 3 Southbound					TH 19 Westbound					TH 3 Northbound					2nd St Eastbound					Int. Total
	Right	Thru	Left	Peds	App. Total	Right	Thru	Left	Peds	App. Total	Right	Thru	Left	Peds	App. Total	Right	Thru	Left	Peds	App. Total	

Peak Hour Analysis From 11:00 AM to 12:45 PM - Peak 1 of 1  
 Peak Hour for Entire Intersection Begins at 11:45 AM

11:45 AM	6	139	28	2	175	20	12	36	0	68	25	115	7	3	150	14	8	4	0	26	419
12:00 PM	6	136	27	1	170	26	11	29	1	67	30	111	4	0	145	14	12	5	0	31	413
12:15 PM	4	105	30	2	141	24	10	31	2	67	19	125	7	2	153	16	15	6	0	37	398
12:30 PM	2	121	20	2	145	29	10	23	0	62	23	124	4	3	154	9	8	7	0	24	385
Total Volume	18	501	105	7	631	99	43	119	3	264	97	475	22	8	602	53	43	22	0	118	1615
% App. Total	2.9	79.4	16.6	1.1		37.5	16.3	45.1	1.1		16.1	78.9	3.7	1.3		44.9	36.4	18.6	0		
PHF	.750	.901	.875	.875	.901	.853	.896	.826	.375	.971	.808	.950	.786	.667	.977	.828	.717	.786	.000	.797	.964

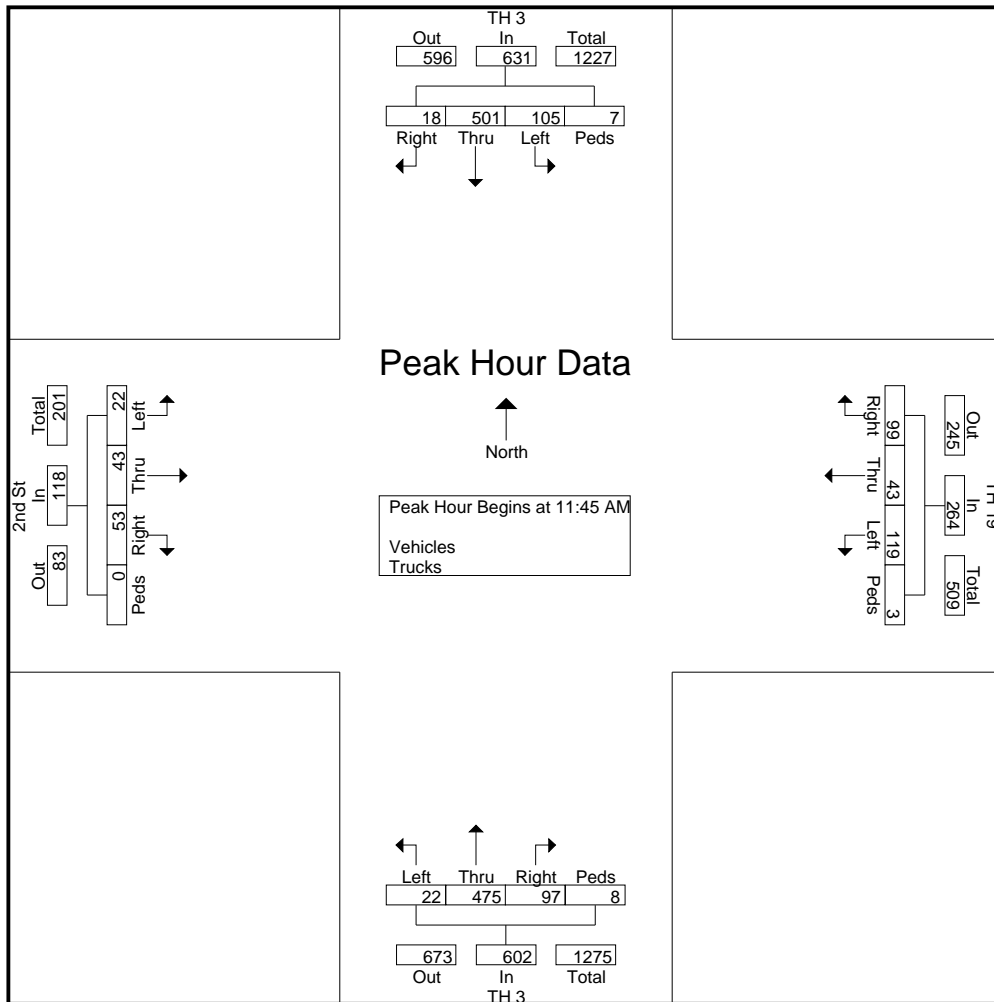

TH 3 at TH 19 N Jct  
 Carto Measure: 12.924  
 Data By: Short Elliott Hendrickson, Inc.  
 TURN MOVEMENT COUNT

File Name : TH 3 & TH 19 N Jct 2019  
 Site Code : 1g  
 Start Date : 10/9/2019  
 Page No : 5

Start Time	TH 3 Southbound					TH 19 Westbound					TH 3 Northbound					2nd St Eastbound					Int. Total
	Right	Thru	Left	Peds	App. Total	Right	Thru	Left	Peds	App. Total	Right	Thru	Left	Peds	App. Total	Right	Thru	Left	Peds	App. Total	

Peak Hour Analysis From 03:00 PM to 05:45 PM - Peak 1 of 1  
 Peak Hour for Entire Intersection Begins at 04:30 PM

04:30 PM	4	218	40	3	265	46	14	57	0	117	33	172	15	0	220	13	8	6	0	27	629
04:45 PM	3	240	41	1	285	53	24	43	0	120	35	148	8	2	193	14	22	6	0	42	640
05:00 PM	5	218	35	3	261	53	21	64	1	139	30	229	10	0	269	18	19	4	0	41	710
05:15 PM	7	206	42	9	264	56	14	48	0	118	29	195	20	5	249	7	22	6	0	35	666
Total Volume	19	882	158	16	1075	208	73	212	1	494	127	744	53	7	931	52	71	22	0	145	2645
% App. Total	1.8	82	14.7	1.5		42.1	14.8	42.9	0.2		13.6	79.9	5.7	0.8		35.9	49	15.2	0		
PHF	.679	.919	.940	.444	.943	.929	.760	.828	.250	.888	.907	.812	.663	.350	.865	.722	.807	.917	.000	.863	.931

