

Your Company Name Here

This is your address
Your City, State, Zip Code
Your Tagline Here

TH 3 & TH 19 S Jct

File Name : TH 3 & TH 19 S Jct 2019

Ref.Pt.:

Site Code : 1f

Data By: Short Elliott Hendrickson, Inc.

Start Date : 10/9/2019

TURN MOVEMENT COUNT

Page No : 1

Groups Printed- Vehicles - Trucks

Start Time	TH 3 From North					5th St From East					TH 3 From South					TH 19 From West					Int. Total
	Right	Thru	Left	Peds	App. Total	Right	Thru	Left	Peds	App. Total	Right	Thru	Left	Peds	App. Total	Right	Thru	Left	Peds	App. Total	
06:00 AM	24	26	2	0	52	8	20	2	0	30	5	92	38	0	135	11	5	16	0	32	249
06:15 AM	28	40	4	0	72	11	36	2	0	49	4	104	44	0	152	13	11	34	0	58	331
06:30 AM	28	70	1	0	99	19	26	1	0	46	3	99	71	0	173	11	8	21	0	40	358
06:45 AM	27	76	3	0	106	10	34	0	0	44	2	92	46	0	140	8	12	41	0	61	351
Total	107	212	10	0	329	48	116	5	0	169	14	387	199	0	600	43	36	112	0	191	1289
07:00 AM	17	103	6	0	126	13	26	3	0	42	6	108	60	0	174	18	13	34	0	65	407
07:15 AM	34	134	16	0	184	24	32	1	0	57	8	130	51	0	189	34	15	45	0	94	524
07:30 AM	25	131	9	0	165	22	26	1	0	49	10	127	69	0	206	20	17	42	0	79	499
07:45 AM	36	142	13	0	191	15	28	3	0	46	6	130	65	0	201	20	25	40	0	85	523
Total	112	510	44	0	666	74	112	8	0	194	30	495	245	0	770	92	70	161	0	323	1953
08:00 AM	36	109	9	0	154	19	23	4	0	46	10	125	60	1	196	16	26	37	0	79	475
08:15 AM	30	120	17	0	167	19	33	7	0	59	11	120	59	0	190	30	24	40	0	94	510
08:30 AM	32	131	23	0	186	17	35	7	0	59	24	137	65	0	226	35	28	39	0	102	573
08:45 AM	17	146	14	0	177	25	50	3	0	78	21	190	82	0	293	32	30	28	0	90	638
Total	115	506	63	0	684	80	141	21	0	242	66	572	266	1	905	113	108	144	0	365	2196
09:00 AM	32	148	17	0	197	25	33	6	0	64	10	101	63	0	174	33	22	33	1	89	524
09:15 AM	36	101	12	1	150	14	44	7	1	66	17	119	74	0	210	32	30	26	0	88	514
09:30 AM	28	109	14	0	151	18	29	9	0	56	13	100	48	0	161	30	24	29	0	83	451
09:45 AM	32	112	12	1	157	15	37	4	4	60	9	77	51	0	137	32	31	33	0	96	450
Total	128	470	55	2	655	72	143	26	5	246	49	397	236	0	682	127	107	121	1	356	1939
10:00 AM	19	88	6	4	117	9	33	14	1	57	13	93	54	0	160	45	22	24	0	91	425
10:15 AM	25	77	15	0	117	22	25	11	0	58	14	99	48	0	161	41	25	24	0	90	426
10:30 AM	28	90	13	0	131	19	20	8	0	47	12	98	55	0	165	29	26	23	0	78	421
10:45 AM	22	79	10	2	113	14	23	12	0	49	10	104	52	0	166	40	27	33	0	100	428
Total	94	334	44	6	478	64	101	45	1	211	49	394	209	0	652	155	100	104	0	359	1700
11:00 AM	30	104	4	0	138	23	35	14	1	73	16	75	75	1	167	38	33	24	0	95	473
11:15 AM	23	99	6	0	128	20	26	9	0	55	17	101	66	1	185	45	36	26	0	107	475
11:30 AM	32	101	10	0	143	21	30	15	0	66	15	92	68	0	175	35	28	31	0	94	478
11:45 AM	29	118	14	0	161	22	40	16	0	78	16	126	65	0	207	33	41	22	1	97	543
Total	114	422	34	0	570	86	131	54	1	272	64	394	274	2	734	151	138	103	1	393	1969
12:00 PM	23	127	13	0	163	22	48	21	0	91	11	104	66	0	181	24	35	29	0	88	523
12:15 PM	30	96	19	0	145	18	40	12	0	70	10	116	70	0	196	26	44	37	0	107	518
12:30 PM	27	122	17	0	166	21	31	19	0	71	11	105	70	0	186	36	39	30	0	105	528
12:45 PM	29	120	19	2	170	24	34	20	0	78	16	104	54	0	174	25	34	32	1	92	514
Total	109	465	68	2	644	85	153	72	0	310	48	429	260	0	737	111	152	128	1	392	2083
01:00 PM	27	110	5	0	142	15	51	16	0	82	11	123	63	0	197	39	31	33	0	103	524
01:15 PM	33	105	7	1	146	23	32	11	0	66	10	109	81	0	200	28	41	25	0	94	506
01:30 PM	21	102	9	3	135	18	46	19	0	83	17	114	78	0	209	36	32	26	0	94	521
01:45 PM	26	121	8	1	156	20	30	11	0	61	9	115	69	0	193	36	22	31	0	89	499
Total	107	438	29	5	579	76	159	57	0	292	47	461	291	0	799	139	126	115	0	380	2050
02:00 PM	25	103	8	4	140	23	45	6	0	74	11	121	71	3	206	29	21	46	0	96	516
02:15 PM	36	135	3	2	176	23	40	19	0	82	12	106	58	0	176	30	38	39	0	107	541
02:30 PM	29	188	20	0	237	21	35	13	0	69	15	126	75	0	216	48	25	25	0	98	620
02:45 PM	33	151	13	0	197	36	54	6	1	97	16	113	71	0	200	49	38	31	0	118	612
Total	123	577	44	6	750	103	174	44	1	322	54	466	275	3	798	156	122	141	0	419	2289

Your Company Name Here

This is your address
Your City, State, Zip Code
Your Tagline Here

TH 3 & TH 19 S Jct

Ref.Pt.:

Data By: Short Elliott Hendrickson, Inc.

TURN MOVEMENT COUNT

File Name : TH 3 & TH 19 S Jct 2019

Site Code : 1f

Start Date : 10/9/2019

Page No : 2

Groups Printed- Vehicles - Trucks

Start Time	TH 3 From North					5th St From East					TH 3 From South					TH 19 From West					Int. Total
	Right	Thru	Left	Peds	App. Total	Right	Thru	Left	Peds	App. Total	Right	Thru	Left	Peds	App. Total	Right	Thru	Left	Peds	App. Total	
03:00 PM	47	138	19	1	205	23	60	11	1	95	17	170	90	0	277	60	26	36	0	122	699
03:15 PM	37	152	8	0	197	36	56	6	0	98	14	105	78	0	197	56	30	34	0	120	612
03:30 PM	44	150	23	0	217	22	50	19	0	91	11	156	85	0	252	82	41	39	0	162	722
03:45 PM	36	173	25	0	234	25	65	13	0	103	16	150	71	0	237	62	31	36	0	129	703
Total	164	613	75	1	853	106	231	49	1	387	58	581	324	0	963	260	128	145	0	533	2736
04:00 PM	47	146	27	0	220	24	55	9	0	88	8	136	80	0	224	86	48	38	0	172	704
04:15 PM	36	188	44	0	268	40	42	9	0	91	16	166	71	0	253	72	24	41	0	137	749
04:30 PM	58	209	25	0	292	43	54	10	0	107	10	152	81	0	243	75	40	42	1	158	800
04:45 PM	44	220	21	0	285	39	64	14	0	117	15	158	98	0	271	65	44	33	0	142	815
Total	185	763	117	0	1065	146	215	42	0	403	49	612	330	0	991	298	156	154	1	609	3068
05:00 PM	57	197	21	0	275	24	64	18	0	106	15	188	79	0	282	98	34	34	0	166	829
05:15 PM	48	194	29	0	271	23	50	15	0	88	17	191	100	0	308	87	36	46	0	169	836
05:30 PM	43	147	15	0	205	29	56	14	0	99	14	142	82	0	238	63	34	31	0	128	670
05:45 PM	37	153	21	1	212	20	37	6	1	64	11	146	68	0	225	52	33	30	0	115	616
Total	185	691	86	1	963	96	207	53	1	357	57	667	329	0	1053	300	137	141	0	578	2951
06:00 PM	30	147	20	0	197	22	42	15	1	80	11	124	55	0	190	43	36	40	0	119	586
06:15 PM	35	149	26	0	210	28	40	18	0	86	17	111	54	1	183	31	32	24	0	87	566
06:30 PM	26	124	22	5	177	14	36	11	0	61	14	107	61	0	182	34	32	32	0	98	518
06:45 PM	25	125	22	1	173	34	37	8	0	79	19	128	56	0	203	24	31	22	0	77	532
Total	116	545	90	6	757	98	155	52	1	306	61	470	226	1	758	132	131	118	0	381	2202
Grand Total	1659	6546	759	29	8993	1134	2038	528	11	3711	646	6325	3464	7	10442	2077	1511	1687	4	5279	28425
Apprch %	18.4	72.8	8.4	0.3		30.6	54.9	14.2	0.3		6.2	60.6	33.2	0.1		39.3	28.6	32	0.1		
Total %	5.8	23	2.7	0.1	31.6	4	7.2	1.9	0	13.1	2.3	22.3	12.2	0	36.7	7.3	5.3	5.9	0	18.6	
Vehicles	1386	6025				1090	1999					5789	3269			1972	1476	1422			26347
% Vehicles	83.5	92	95.3	96.6	90.8	96.1	98.1	97.3	100	97.4	98.3	91.5	94.4	85.7	92.9	94.9	97.7	84.3	50	92.3	92.7
Trucks	273	521	36	1	831	44	39	14	0	97	11	536	195	1	743	105	35	265	2	407	2078
% Trucks	16.5	8	4.7	3.4	9.2	3.9	1.9	2.7	0	2.6	1.7	8.5	5.6	14.3	7.1	5.1	2.3	15.7	50	7.7	7.3

Your Company Name Here

This is your address
Your City, State, Zip Code
Your Tagline Here

TH 3 & TH 19 S Jct

Ref.Pt.:

Data By: Short Elliott Hendrickson, Inc.

TURN MOVEMENT COUNT

File Name : TH 3 & TH 19 S Jct 2019

Site Code : 1f

Start Date : 10/9/2019

Page No : 3

Start Time	TH 3 From North					5th St From East					TH 3 From South					TH 19 From West					Int. Total
	Right	Thru	Left	Peds	App. Total	Right	Thru	Left	Peds	App. Total	Right	Thru	Left	Peds	App. Total	Right	Thru	Left	Peds	App. Total	

Peak Hour Analysis From 06:00 AM to 08:45 AM - Peak 1 of 1

Peak Hour for Entire Intersection Begins at 08:00 AM

08:00 AM	36	109	9	0	154	19	23	4	0	46	10	125	60	1	196	16	26	37	0	79	475
08:15 AM	30	120	17	0	167	19	33	7	0	59	11	120	59	0	190	30	24	40	0	94	510
08:30 AM	32	131	23	0	186	17	35	7	0	59	24	137	65	0	226	35	28	39	0	102	573
08:45 AM	17	146	14	0	177	25	50	3	0	78	21	190	82	0	293	32	30	28	0	90	638
Total Volume	115	506	63	0	684	80	141	21	0	242	66	572	266	1	905	113	108	144	0	365	2196
% App. Total	16.8	74	9.2	0		33.1	58.3	8.7	0		7.3	63.2	29.4	0.1		31	29.6	39.5	0		
PHF	.799	.866	.685	.000	.919	.800	.705	.750	.000	.776	.688	.753	.811	.250	.772	.807	.900	.900	.000	.895	.861

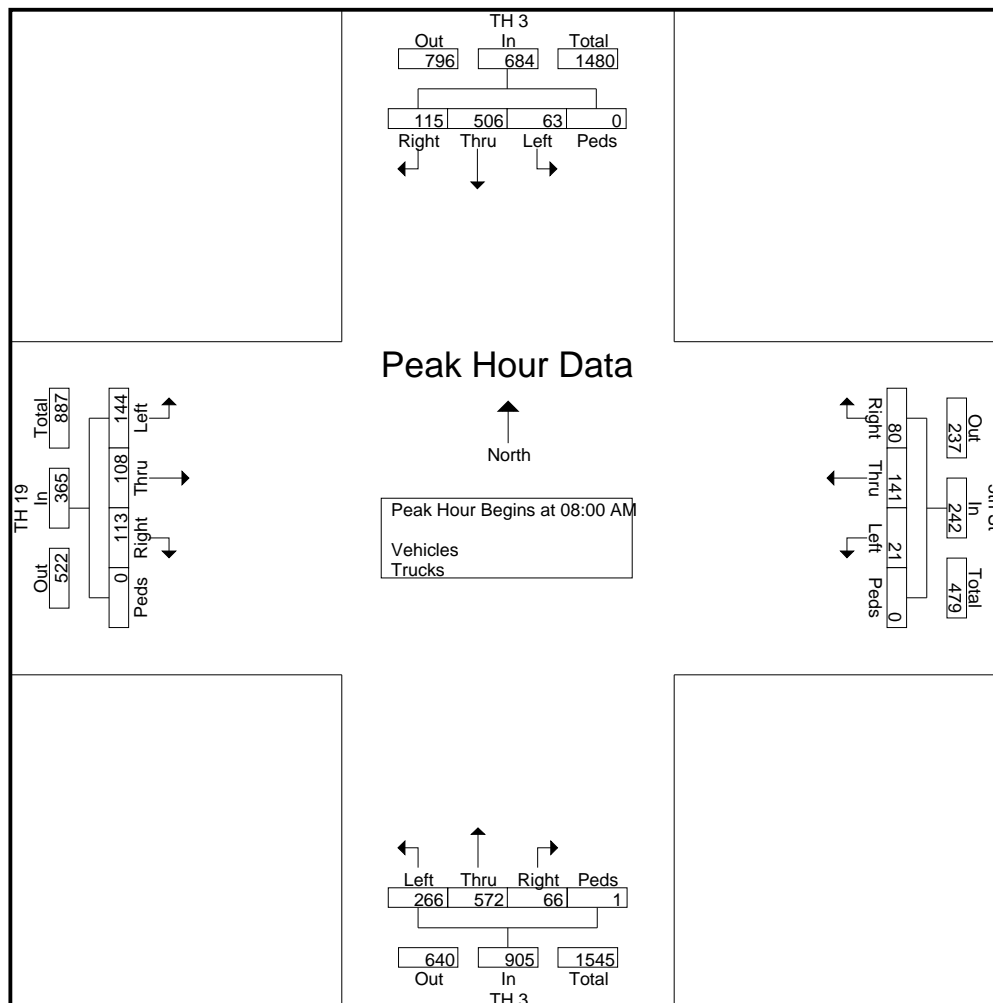

Your Company Name Here

This is your address
Your City, State, Zip Code
Your Tagline Here

TH 3 & TH 19 S Jct
Ref.Pt.:
Data By: Short Elliott Hendrickson, Inc.
TURN MOVEMENT COUNT

File Name : TH 3 & TH 19 S Jct 2019
Site Code : 1f
Start Date : 10/9/2019
Page No : 4

Start Time	TH 3 From North					5th St From East					TH 3 From South					TH 19 From West					Int. Total
	Right	Thru	Left	Peds	App. Total	Right	Thru	Left	Peds	App. Total	Right	Thru	Left	Peds	App. Total	Right	Thru	Left	Peds	App. Total	
Peak Hour Analysis From 11:00 AM to 12:45 PM - Peak 1 of 1																					
Peak Hour for Entire Intersection Begins at 11:45 AM																					
11:45 AM	29	118	14	0	161	22	40	16	0	78	16	126	65	0	207	33	41	22	1	97	543
12:00 PM	23	127	13	0	163	22	48	21	0	91	11	104	66	0	181	24	35	29	0	88	523
12:15 PM	30	96	19	0	145	18	40	12	0	70	10	116	70	0	196	26	44	37	0	107	518
12:30 PM	27	122	17	0	166	21	31	19	0	71	11	105	70	0	186	36	39	30	0	105	528
Total Volume	109	463	63	0	635	83	159	68	0	310	48	451	271	0	770	119	159	118	1	397	2112
% App. Total	17.2	72.9	9.9	0		26.8	51.3	21.9	0		6.2	58.6	35.2	0		30	40.1	29.7	0.3		
PHF	.908	.911	.829	.000	.956	.943	.828	.810	.000	.852	.750	.895	.968	.000	.930	.826	.903	.797	.250	.928	.972

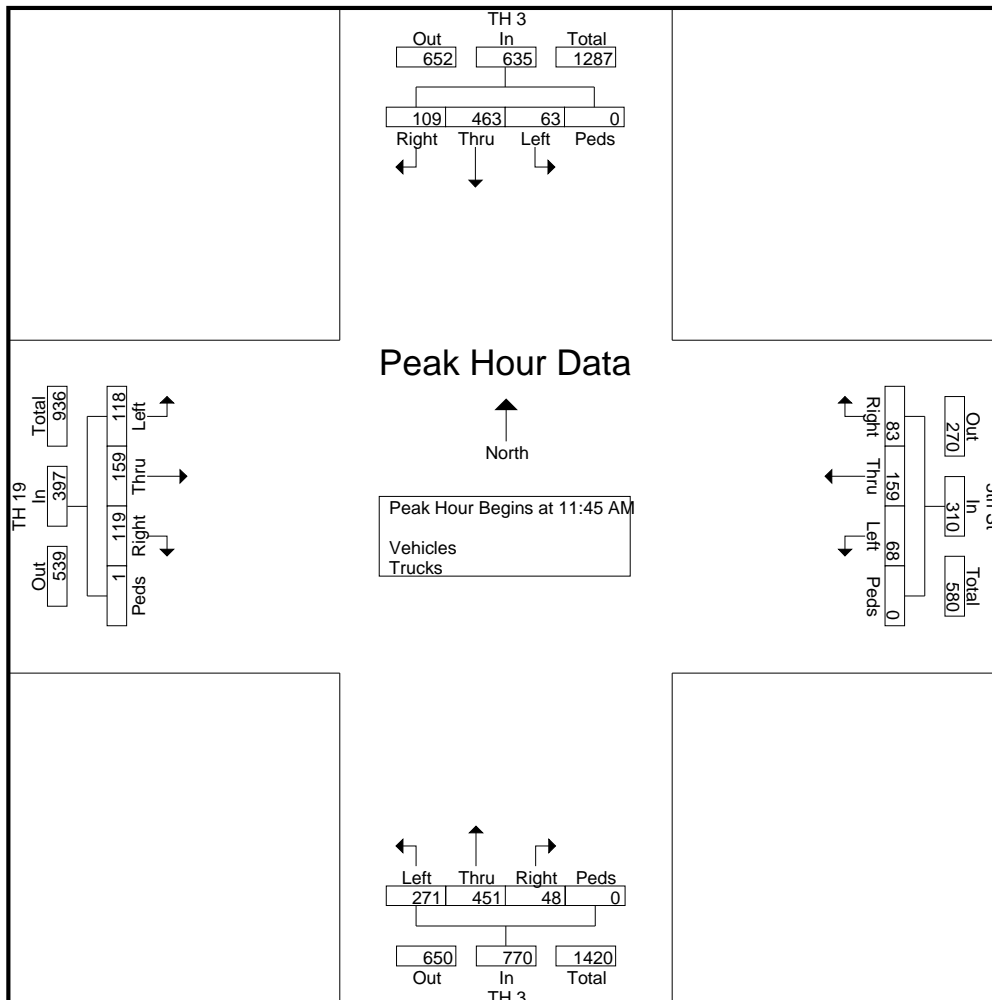

Your Company Name Here

This is your address
 Your City, State, Zip Code
Your Tagline Here

TH 3 & TH 19 S Jct

Ref.Pt.:

Data By: Short Elliott Hendrickson, Inc.

TURN MOVEMENT COUNT

File Name : TH 3 & TH 19 S Jct 2019

Site Code : 1f

Start Date : 10/9/2019

Page No : 5

Start Time	TH 3 From North					5th St From East					TH 3 From South					TH 19 From West					Int. Total
	Right	Thru	Left	Peds	App. Total	Right	Thru	Left	Peds	App. Total	Right	Thru	Left	Peds	App. Total	Right	Thru	Left	Peds	App. Total	
Peak Hour Analysis From 03:00 PM to 05:45 PM - Peak 1 of 1																					
Peak Hour for Entire Intersection Begins at 04:30 PM																					
04:30 PM	58	209	25	0	292	43	54	10	0	107	10	152	81	0	243	75	40	42	1	158	800
04:45 PM	44	220	21	0	285	39	64	14	0	117	15	158	98	0	271	65	44	33	0	142	815
05:00 PM	57	197	21	0	275	24	64	18	0	106	15	188	79	0	282	98	34	34	0	166	829
05:15 PM	48	194	29	0	271	23	50	15	0	88	17	191	100	0	308	87	36	46	0	169	836
Total Volume	207	820	96	0	1123	129	232	57	0	418	57	689	358	0	1104	325	154	155	1	635	3280
% App. Total	18.4	73	8.5	0		30.9	55.5	13.6	0		5.2	62.4	32.4	0		51.2	24.3	24.4	0.2		
PHF	.892	.932	.828	.000	.961	.750	.906	.792	.000	.893	.838	.902	.895	.000	.896	.829	.875	.842	.250	.939	.981

