



MINNESOTA DEPT OF TRANSPORTATION

TRAFFIC DATA COLLECTION - METRO

TH-41 at Co.Rd.61 /Chaska Blvd/W 6th St
 Ref.Pt.: 002.026 CHASKA
 JAMAR # T-2638 CAH
 TURN MOVEMENT COUNT

File Name : TH-41 at Chaska Blvd 2010
 Site Code : 00000000
 Start Date : 10/28/2010
 Page No : 1

Groups Printed- Cars & Trucks

Start Time	TH-41 / Chestnut St. Southbound				Co.Rd. 61 / Chaska Blvd. Westbound				TH-41 / Chestnut St. Northbound				Co.Rd. 61 / W 6th St. Eastbound				Int. Total
	Left	Thru	Right	Peds	Left	Thru	Right	Peds	Left	Thru	Right	Peds	Left	Thru	Right	Peds	
06:00	1	27	12	0	8	7	1	0	9	50	6	0	15	40	27	0	203
06:15	4	51	9	0	7	9	4	0	18	53	11	0	28	34	26	0	254
06:30	1	64	2	0	15	6	4	0	14	95	22	0	35	46	40	0	344
06:45	9	81	6	0	15	8	4	0	26	115	26	0	29	48	71	0	438
Total	15	223	29	0	45	30	13	0	67	313	65	0	107	168	164	0	1239
07:00	12	73	6	0	14	14	8	0	25	98	20	0	43	69	47	0	429
07:15	12	90	11	0	16	14	4	0	36	118	22	0	31	60	50	0	464
07:30	15	83	12	0	14	13	7	0	26	119	27	0	37	89	45	0	487
07:45	17	116	5	0	23	17	6	0	22	123	20	0	30	87	39	0	505
Total	56	362	34	0	67	58	25	0	109	458	89	0	141	305	181	0	1885
08:00	21	91	5	0	21	20	9	0	23	91	16	0	39	53	36	0	425
08:15	19	107	12	0	19	15	8	0	22	83	19	0	27	38	36	0	405
08:30	17	78	10	0	19	23	6	0	26	88	27	0	31	53	39	2	419
08:45	13	92	25	0	26	27	4	0	16	90	13	0	28	44	30	0	408
Total	70	368	52	0	85	85	27	0	87	352	75	0	125	188	141	2	1657
*** BREAK ***																	
15:00	12	96	22	0	37	47	15	1	32	87	13	0	39	28	22	0	451
15:15	17	139	26	1	34	61	6	0	45	94	18	1	37	27	17	1	524
15:30	9	119	26	0	35	61	6	0	46	90	17	1	35	38	28	0	511
15:45	24	129	26	0	32	57	6	0	54	93	19	0	35	39	16	0	530
Total	62	483	100	1	138	226	33	1	177	364	67	2	146	132	83	1	2016
16:00	17	128	24	0	37	66	13	0	45	92	20	0	41	36	23	0	542
16:15	16	134	29	0	53	78	9	0	75	130	21	2	53	23	28	0	651
16:30	18	126	44	0	41	80	16	0	71	111	27	1	28	42	26	2	633
16:45	17	160	38	1	38	80	10	1	66	133	19	1	50	51	23	1	689
Total	68	548	135	1	169	304	48	1	257	466	87	4	172	152	100	3	2515
17:00	11	138	24	0	51	68	8	0	85	122	25	0	39	40	32	0	643
17:15	27	133	31	0	41	81	13	0	59	122	17	0	40	37	17	0	618
17:30	21	127	29	0	49	70	21	0	54	108	21	0	42	45	19	0	606
17:45	17	115	29	0	36	67	15	0	59	137	14	0	41	27	27	0	584
Total	76	513	113	0	177	286	57	0	257	489	77	0	162	149	95	0	2451
Grand Total	347	2497	463	2	681	989	203	2	954	2442	460	6	853	1094	764	6	11763
Apprch %	10.5	75.5	14	0.1	36.3	52.7	10.8	0.1	24.7	63.2	11.9	0.2	31.4	40.3	28.1	0.2	
Total %	2.9	21.2	3.9	0	5.8	8.4	1.7	0	8.1	20.8	3.9	0.1	7.3	9.3	6.5	0.1	



MINNESOTA DEPT OF TRANSPORTATION

TRAFFIC DATA COLLECTION - METRO

TH-41 at Co.Rd.61 /Chaska Blvd/W 6th St
 Ref.Pt.: 002.026 CHASKA
 JAMAR # T-2638 CAH
 TURN MOVEMENT COUNT

File Name : TH-41 at Chaska Blvd 2010
 Site Code : 00000000
 Start Date : 10/28/2010
 Page No : 2

Start Time	TH-41 / Chestnut St. Southbound					Co.Rd. 61 / Chaska Blvd. Westbound					TH-41 / Chestnut St. Northbound					Co.Rd. 61 / W 6th St. Eastbound					Int. Total
	Left	Thru	Right	Peds	App. Total	Left	Thru	Right	Peds	App. Total	Left	Thru	Right	Peds	App. Total	Left	Thru	Right	Peds	App. Total	
Peak Hour Analysis From 06:00 to 08:45 - Peak 1 of 1																					
Peak Hour for Entire Intersection Begins at 07:00																					
07:00	12	73	6	0	91	14	14	8	0	36	25	98	20	0	143	43	69	47	0	159	429
07:15	12	90	11	0	113	16	14	4	0	34	36	118	22	0	176	31	60	50	0	141	464
07:30	15	83	12	0	110	14	13	7	0	34	26	119	27	0	172	37	89	45	0	171	487
07:45	17	116	5	0	138	23	17	6	0	46	22	123	20	0	165	30	87	39	0	156	505
Total Volume	56	362	34	0	452	67	58	25	0	150	109	458	89	0	656	141	305	181	0	627	1885
% App. Total	12.4	80.1	7.5	0		44.7	38.7	16.7	0		16.6	69.8	13.6	0		22.5	48.6	28.9	0		
PHF	.824	.780	.708	.000	.819	.728	.853	.781	.000	.815	.757	.931	.824	.000	.932	.820	.857	.905	.000	.917	.933

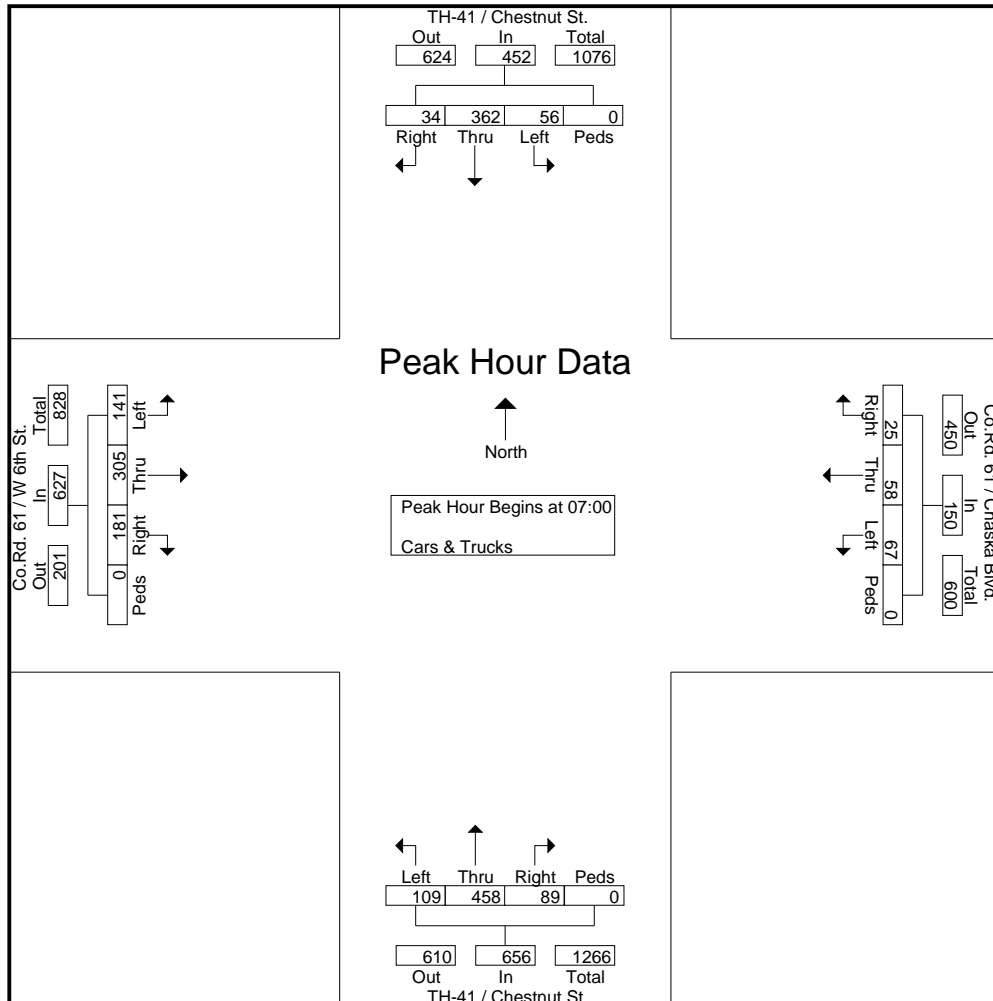



MINNESOTA DEPT OF TRANSPORTATION

TRAFFIC DATA COLLECTION - METRO

TH-41 at Co.Rd.61 /Chaska Blvd/W 6th St
 Ref.Pt.: 002.026 CHASKA
 JAMAR # T-2638 CAH
 TURN MOVEMENT COUNT

File Name : TH-41 at Chaska Blvd 2010
 Site Code : 00000000
 Start Date : 10/28/2010
 Page No : 3

Start Time	TH-41 / Chestnut St. Southbound					Co.Rd. 61 / Chaska Blvd. Westbound					TH-41 / Chestnut St. Northbound					Co.Rd. 61 / W 6th St. Eastbound					Int. Total
	Left	Thru	Right	Peds	App. Total	Left	Thru	Right	Peds	App. Total	Left	Thru	Right	Peds	App. Total	Left	Thru	Right	Peds	App. Total	

Peak Hour Analysis From 15:00 to 17:45 - Peak 1 of 1
 Peak Hour for Entire Intersection Begins at 16:15

16:15	16	134	29	0	179	53	78	9	0	140	75	130	21	2	228	53	23	28	0	104	651
16:30	18	126	44	0	188	41	80	16	0	137	71	111	27	1	210	28	42	26	2	98	633
16:45	17	160	38	1	216	38	80	10	1	129	66	133	19	1	219	50	51	23	1	125	689
17:00	11	138	24	0	173	51	68	8	0	127	85	122	25	0	232	39	40	32	0	111	643
Total Volume	62	558	135	1	756	183	306	43	1	533	297	496	92	4	889	170	156	109	3	438	2616
% App. Total	8.2	73.8	17.9	0.1		34.3	57.4	8.1	0.2		33.4	55.8	10.3	0.4		38.8	35.6	24.9	0.7		
PHF	.861	.872	.767	.250	.875	.863	.956	.672	.250	.952	.874	.932	.852	.500	.958	.802	.765	.852	.375	.876	.949

