



MINNESOTA DEPT OF TRANSPORTATION

TRAFFIC DATA COLLECTION - METRO

TH-41 at Chaska Blvd (old TH-212)
 Ref.Pt.: 002.026
 Data by: Westwood Professional Services
 TURN MOVEMENT COUNT

File Name : TH-41 at Chaska Blvd -old TH212 2008
 Site Code : 28044123
 Start Date : 10/23/2008
 Page No : 1

Groups Printed- Unshifted

Start Time	TH-41 / N Chestnut St. Southbound				Chaska Blvd. (Old TH-212) Westbound				TH-41 / N Chestnut St. Northbound				Chaska Blvd. Eastbound				Int. Total
	Left	Thru	Right	Peds	Left	Thru	Right	Peds	Left	Thru	Right	Peds	Left	Thru	Right	Peds	
06:00	2	43	7	0	13	13	6	0	11	69	3	0	21	29	22	0	239
06:15	2	52	7	0	14	8	3	0	18	70	15	0	20	37	49	0	295
06:30	7	70	2	0	8	14	3	0	23	112	16	0	33	37	45	0	370
06:45	8	70	6	0	6	9	8	0	21	120	25	0	35	30	50	0	388
Total	19	235	22	0	41	44	20	0	73	371	59	0	109	133	166	0	1292
07:00	9	98	5	0	13	9	4	0	37	118	13	0	39	43	50	0	438
07:15	18	122	8	0	11	10	2	0	29	123	17	0	24	65	51	0	480
07:30	23	137	3	0	24	13	6	0	22	165	33	0	31	67	52	0	576
07:45	26	116	5	0	16	14	5	0	17	130	19	0	33	54	42	0	477
Total	76	473	21	0	64	46	17	0	105	536	82	0	127	229	195	0	1971
08:00	14	91	8	0	21	19	8	0	20	126	13	0	21	41	43	0	425
08:15	13	81	3	0	18	19	5	0	11	108	13	0	18	34	29	0	352
08:30	12	85	10	0	13	7	3	0	22	101	13	0	22	23	20	0	331
08:45	16	116	15	0	26	22	7	0	23	116	11	0	31	31	22	0	436
Total	55	373	36	0	78	67	23	0	76	451	50	0	92	129	114	0	1544
*** BREAK ***																	
11:00	20	85	8	0	19	25	11	0	16	98	17	0	27	31	15	0	372
11:15	20	85	8	0	23	24	15	0	21	76	15	0	27	31	15	0	360
11:30	18	122	16	0	30	36	14	0	17	84	28	0	23	17	14	0	419
11:45	16	100	17	0	26	26	16	0	20	77	32	0	18	22	8	0	378
Total	74	392	49	0	98	111	56	0	74	335	92	0	95	101	52	0	1529
12:00	18	96	13	0	30	23	13	0	30	102	16	0	19	25	14	0	399
12:15	23	99	18	0	32	35	18	0	22	88	22	0	19	28	13	0	417
12:30	15	78	20	0	37	31	18	0	16	104	18	0	32	30	24	0	423
12:45	22	104	16	0	23	29	7	0	16	95	21	0	23	27	20	0	403
Total	78	377	67	0	122	118	56	0	84	389	77	0	93	110	71	0	1642
*** BREAK ***																	
14:45	0	0	0	0	28	52	6	0	29	83	12	0	0	0	0	0	210
Total	0	0	0	0	28	52	6	0	29	83	12	0	0	0	0	0	210
15:00	10	117	17	0	33	54	8	0	26	107	25	0	21	18	18	0	454
15:15	10	135	15	0	37	51	7	0	27	110	13	0	25	21	24	0	475
15:30	12	138	25	0	35	45	8	0	30	67	14	0	28	23	24	0	449
15:45	16	115	28	0	40	52	12	0	63	113	17	0	37	28	19	0	540
Total	48	505	85	0	145	202	35	0	146	397	69	0	111	90	85	0	1918
16:00	13	111	22	0	43	51	7	0	39	115	18	0	32	26	22	0	499
16:15	16	153	33	0	38	62	13	0	36	117	21	0	32	24	28	0	573
16:30	11	142	30	0	47	89	5	0	62	153	27	0	55	23	19	0	663
16:45	19	163	17	0	37	61	13	0	44	150	24	0	60	42	23	0	653
Total	59	569	102	0	165	263	38	0	181	535	90	0	179	115	92	0	2388
17:00	18	147	29	0	48	60	23	0	45	126	25	0	40	32	19	0	612
17:15	12	121	17	0	44	77	12	0	60	136	13	0	34	34	22	0	582
17:30	23	139	26	0	40	60	8	0	49	135	20	0	35	25	14	0	574
17:45	24	93	17	0	40	60	8	0	49	135	20	0	26	22	11	0	505
Total	77	500	89	0	172	257	51	0	203	532	78	0	135	113	66	0	2273



MINNESOTA DEPT OF TRANSPORTATION

TRAFFIC DATA COLLECTION - METRO

TH-41 at Chaska Blvd (old TH-212)
 Ref.Pt.: 002.026
 Data by: Westwood Professional Services
 TURN MOVEMENT COUNT

File Name : TH-41 at Chaska Blvd -old TH212 2008
 Site Code : 28044123
 Start Date : 10/23/2008
 Page No : 2

Groups Printed- Unshifted

	TH-41 / N Chestnut St. Southbound				Chaska Blvd. (Old TH-212) Westbound				TH-41 / N Chestnut St. Northbound				Chaska Blvd. Eastbound				Int. Total
	Left	Thru	Right	Peds	Left	Thru	Right	Peds	Left	Thru	Right	Peds	Left	Thru	Right	Peds	
Grand Total	486	3424	471	0	913	1160	302	0	971	3629	609	0	941	1020	841	0	14767
Apprch %	11.1	78.2	10.8	0	38.4	48.8	12.7	0	18.6	69.7	11.7	0	33.6	36.4	30	0	
Total %	3.3	23.2	3.2	0	6.2	7.9	2	0	6.6	24.6	4.1	0	6.4	6.9	5.7	0	



MINNESOTA DEPT OF TRANSPORTATION

TRAFFIC DATA COLLECTION - METRO

TH-41 at Chaska Blvd (old TH-212)
 Ref.Pt.: 002.026
 Data by: Westwood Professional Services
 TURN MOVEMENT COUNT

File Name : TH-41 at Chaska Blvd -old TH212 2008
 Site Code : 28044123
 Start Date : 10/23/2008
 Page No : 3

Start Time	TH-41 / N Chestnut St. Southbound					Chaska Blvd. (Old TH-212) Westbound					TH-41 / N Chestnut St. Northbound					Chaska Blvd. Eastbound					Int. Total
	Left	Thru	Right	Peds	App. Total	Left	Thru	Right	Peds	App. Total	Left	Thru	Right	Peds	App. Total	Left	Thru	Right	Peds	App. Total	
Peak Hour Analysis From 06:00 to 08:45 - Peak 1 of 1																					
Peak Hour for Entire Intersection Begins at 07:00																					
07:00	9	98	5	0	112	13	9	4	0	26	37	118	13	0	168	39	43	50	0	132	438
07:15	18	122	8	0	148	11	10	2	0	23	29	123	17	0	169	24	65	51	0	140	480
07:30	23	137	3	0	163	24	13	6	0	43	22	165	33	0	220	31	67	52	0	150	576
07:45	26	116	5	0	147	16	14	5	0	35	17	130	19	0	166	33	54	42	0	129	477
Total Volume	76	473	21	0	570	64	46	17	0	127	105	536	82	0	723	127	229	195	0	551	1971
% App. Total	13.3	83	3.7	0		50.4	36.2	13.4	0		14.5	74.1	11.3	0		23	41.6	35.4	0		
PHF	.731	.863	.656	.000	.874	.667	.821	.708	.000	.738	.709	.812	.621	.000	.822	.814	.854	.938	.000	.918	.855

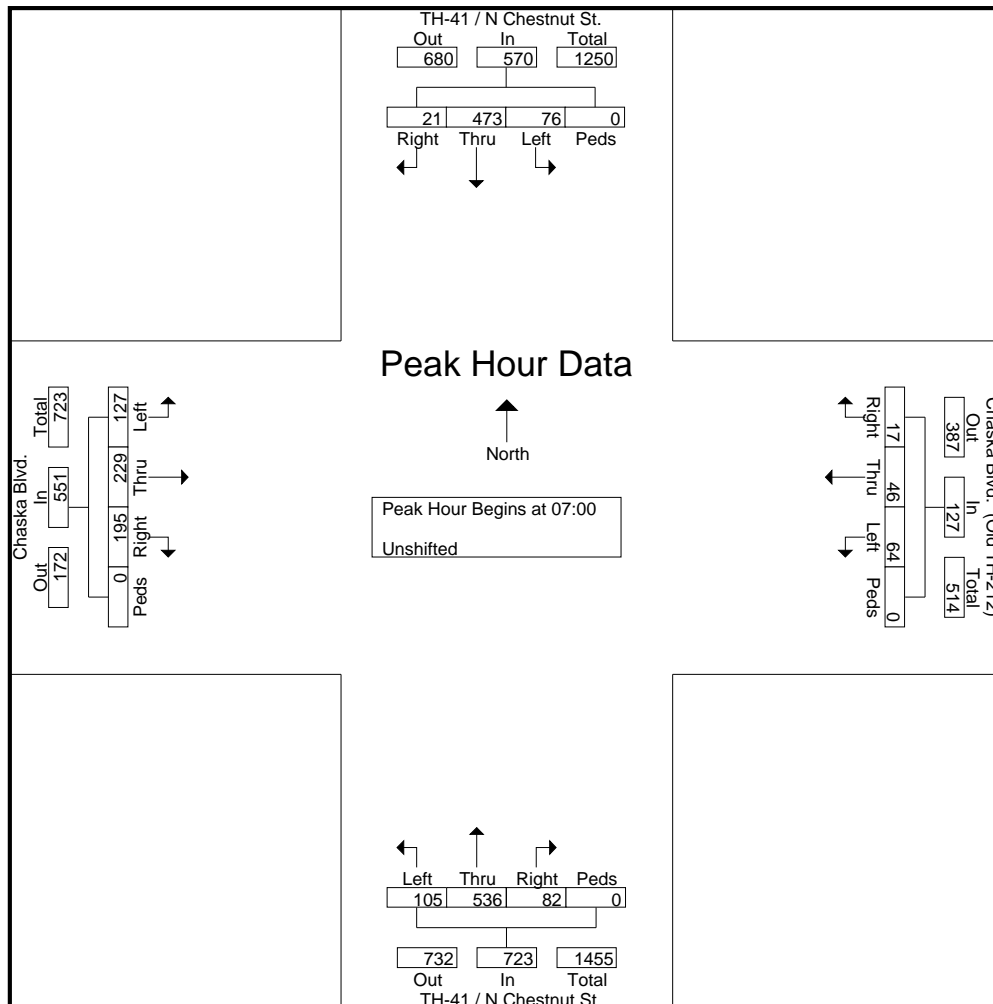



MINNESOTA DEPT OF TRANSPORTATION

TRAFFIC DATA COLLECTION - METRO

TH-41 at Chaska Blvd (old TH-212)
 Ref.Pt.: 002.026
 Data by: Westwood Professional Services
 TURN MOVEMENT COUNT

File Name : TH-41 at Chaska Blvd -old TH212 2008
 Site Code : 28044123
 Start Date : 10/23/2008
 Page No : 4

Start Time	TH-41 / N Chestnut St. Southbound					Chaska Blvd. (Old TH-212) Westbound					TH-41 / N Chestnut St. Northbound					Chaska Blvd. Eastbound					Int. Total
	Left	Thru	Right	Peds	App. Total	Left	Thru	Right	Peds	App. Total	Left	Thru	Right	Peds	App. Total	Left	Thru	Right	Peds	App. Total	

Peak Hour Analysis From 15:00 to 17:45 - Peak 1 of 1

Peak Hour for Entire Intersection Begins at 16:30

16:30	11	142	30	0	183	47	89	5	0	141	62	153	27	0	242	55	23	19	0	97	663
16:45	19	163	17	0	199	37	61	13	0	111	44	150	24	0	218	60	42	23	0	125	653
17:00	18	147	29	0	194	48	60	23	0	131	45	126	25	0	196	40	32	19	0	91	612
17:15	12	121	17	0	150	44	77	12	0	133	60	136	13	0	209	34	34	22	0	90	582
Total Volume	60	573	93	0	726	176	287	53	0	516	211	565	89	0	865	189	131	83	0	403	2510
% App. Total	8.3	78.9	12.8	0		34.1	55.6	10.3	0		24.4	65.3	10.3	0		46.9	32.5	20.6	0		
PHF	.789	.879	.775	.000	.912	.917	.806	.576	.000	.915	.851	.923	.824	.000	.894	.788	.780	.902	.000	.806	.946

