



# MINNESOTA DEPT OF TRANSPORTATION

## TRAFFIC DATA COLLECTION - METRO

TH-41 at Hazeltine Blvd CHASKA  
 Ref.Pt.; 005.205  
 Video RE  
 TURN MOVEMENT COUNT

File Name : TH-41 at Hazeltine Blvd 2013  
 Site Code :  
 Start Date : 11/20/2013  
 Page No : 1

Groups Printed- Cars +

Start Time	TH-41 Southbound				Hazeltine Blvd Westbound				TH-41 Northbound				Hazeltine Blvd Eastbound				Int. Total	
	Right	Thru	Left	Peds	Right	Thru	Left	Peds	Right	Thru	Left	Peds	Right	Thru	Left	Peds		
06:00	0	24	4	0	5	0	5	0	7	86	0	0	0	0	0	0	0	131
06:15	0	26	8	0	14	0	3	0	10	99	1	0	1	0	0	0	0	162
06:30	0	38	8	0	13	0	4	0	11	128	0	0	0	0	0	0	0	202
06:45	0	37	16	0	9	0	8	0	23	189	1	0	0	1	1	0	0	285
Total	0	125	36	0	41	0	20	0	51	502	2	0	1	1	1	0	0	780
07:00	0	76	19	0	19	0	4	0	23	151	0	0	0	1	5	0	0	298
07:15	0	82	12	0	17	0	8	0	26	195	0	0	0	0	1	0	0	341
07:30	0	58	17	0	20	0	6	0	21	209	0	0	0	1	7	0	0	339
07:45	1	81	24	0	17	1	7	0	19	270	0	0	0	1	12	0	0	433
Total	1	297	72	0	73	1	25	0	89	825	0	0	0	3	25	0	0	1411
08:00	0	82	19	0	22	1	12	0	21	204	0	0	0	2	7	0	0	370
08:15	0	67	11	0	12	0	9	0	16	140	0	0	1	2	2	0	0	260
08:30	0	93	10	0	8	0	14	0	20	157	0	0	0	1	1	0	0	304
08:45	0	67	20	0	4	0	9	0	26	178	0	0	0	1	0	0	0	305
Total	0	309	60	0	46	1	44	0	83	679	0	0	1	6	10	0	0	1239
***** BREAK*****																		
11:00	0	86	28	0	16	0	15	0	23	94	0	0	0	0	1	0	0	263
11:15	1	86	40	0	18	1	16	0	33	85	0	0	0	1	1	0	0	282
11:30	1	100	49	0	19	2	20	0	24	100	3	0	1	1	1	0	0	321
11:45	1	109	49	0	32	1	15	0	21	106	0	0	0	1	1	0	0	336
Total	3	381	166	0	85	4	66	0	101	385	3	0	1	3	4	0	0	1202
12:00	0	144	58	0	17	0	34	0	36	114	0	0	0	0	7	0	0	410
12:15	2	111	36	0	39	0	11	0	23	112	1	0	1	0	1	0	0	337
12:30	0	107	49	0	21	2	16	0	23	131	0	0	0	0	1	0	0	350
12:45	2	72	30	0	35	0	18	0	21	115	1	0	0	1	2	0	0	297
Total	4	434	173	0	112	2	79	0	103	472	2	0	1	1	11	0	0	1394
***** BREAK*****																		
15:00	2	185	30	0	22	2	13	0	12	98	1	0	0	1	2	0	0	368
15:15	3	155	25	0	22	0	19	0	13	105	2	0	0	1	1	0	0	346
15:30	3	186	37	0	15	0	15	0	21	115	1	0	0	1	3	0	0	397
15:45	2	127	26	0	14	2	12	0	16	114	4	0	0	0	0	0	0	317
Total	10	653	118	0	73	4	59	0	62	432	8	0	0	3	6	0	0	1428
16:00	0	161	43	0	30	0	24	0	19	135	2	0	0	0	2	0	0	416
16:15	1	197	37	0	24	1	19	0	20	109	2	0	1	2	0	0	0	413
16:30	1	207	34	0	20	1	18	0	20	120	3	0	0	0	2	0	0	426
16:45	1	188	28	0	27	0	15	0	23	127	2	0	0	1	2	0	0	414
Total	3	753	142	0	101	2	76	0	82	491	9	0	1	3	6	0	0	1669
17:00	7	175	33	0	30	2	24	0	14	129	7	0	1	0	1	0	0	423
17:15	3	215	49	0	18	0	18	0	16	109	3	0	0	1	1	0	0	433
17:30	5	141	33	0	21	1	19	0	17	112	3	0	0	0	0	0	0	352
17:45	3	147	32	0	20	0	14	0	13	105	1	0	0	0	0	0	0	335
Total	18	678	147	0	89	3	75	0	60	455	14	0	1	1	2	0	0	1543
Grand Total	39	3630	914	0	620	17	444	0	631	4241	38	0	6	21	65	0	0	10666
Apprch %	0.9	79.2	19.9	0	57.4	1.6	41.1	0	12.9	86.4	0.8	0	6.5	22.8	70.7	0	0	
Total %	0.4	34	8.6	0	5.8	0.2	4.2	0	5.9	39.8	0.4	0	0.1	0.2	0.6	0	0	



# MINNESOTA DEPT OF TRANSPORTATION

## TRAFFIC DATA COLLECTION - METRO

TH-41 at Hazeltine Blvd CHASKA  
 Ref.Pt.; 005.205  
 Video RE  
 TURN MOVEMENT COUNT

File Name : TH-41 at Hazeltine Blvd 2013  
 Site Code :  
 Start Date : 11/20/2013  
 Page No : 2

Start Time	TH-41 Southbound					Hazeltine Blvd Westbound					TH-41 Northbound					Hazeltine Blvd Eastbound					Int. Total
	Right	Thru	Left	Peds	App. Total	Right	Thru	Left	Peds	App. Total	Right	Thru	Left	Peds	App. Total	Right	Thru	Left	Peds	App. Total	
Peak Hour Analysis From 06:00 to 08:45 - Peak 1 of 1																					
Peak Hour for Entire Intersection Begins at 07:15																					
07:15	0	82	12	0	94	17	0	8	0	25	26	195	0	0	221	0	0	1	0	1	341
07:30	0	58	17	0	75	20	0	6	0	26	21	209	0	0	230	0	1	7	0	8	339
07:45	1	81	24	0	106	17	1	7	0	25	19	270	0	0	289	0	1	12	0	13	433
08:00	0	82	19	0	101	22	1	12	0	35	21	204	0	0	225	0	2	7	0	9	370
Total Volume	1	303	72	0	376	76	2	33	0	111	87	878	0	0	965	0	4	27	0	31	1483
% App. Total	0.3	80.6	19.1	0		68.5	1.8	29.7	0		9	91	0	0		0	12.9	87.1	0		
PHF	.250	.924	.750	.000	.887	.864	.500	.688	.000	.793	.837	.813	.000	.000	.835	.000	.500	.563	.000	.596	.856

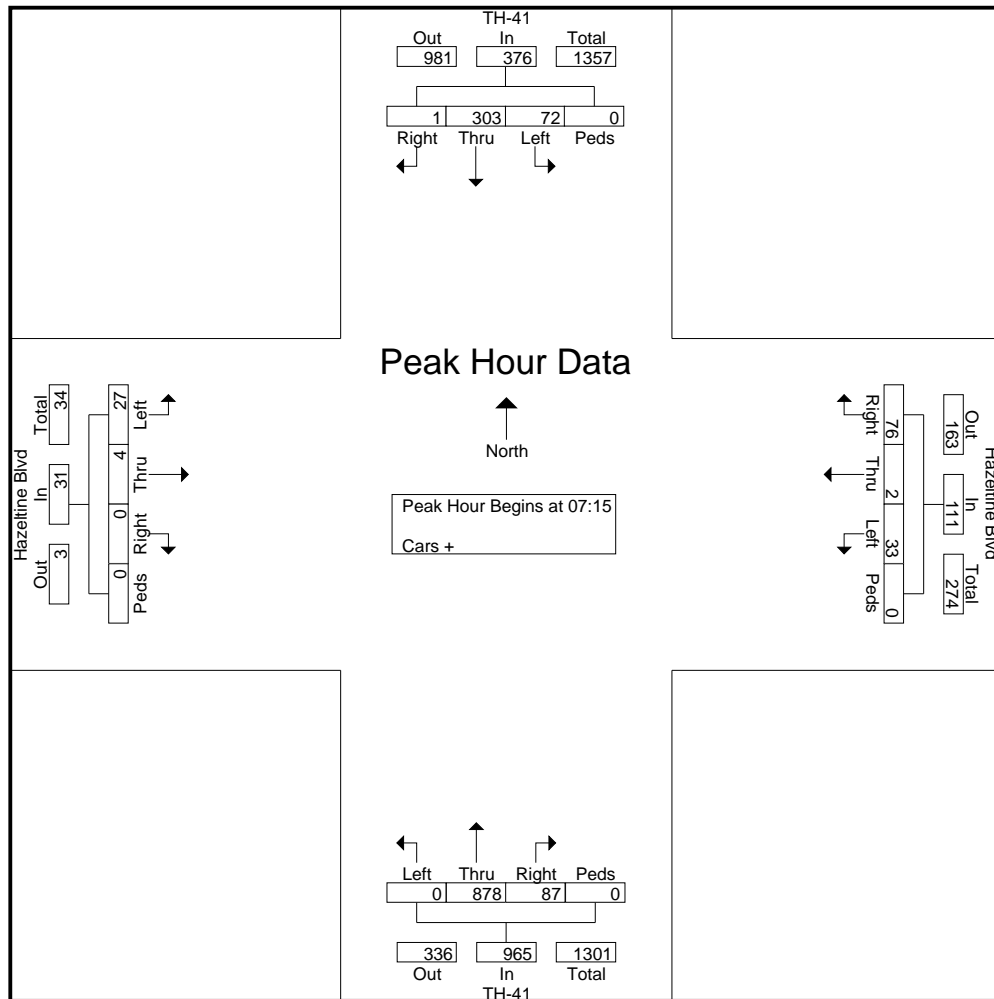



# MINNESOTA DEPT OF TRANSPORTATION

## TRAFFIC DATA COLLECTION - METRO

TH-41 at Hazeltine Blvd CHASKA  
 Ref.Pt.; 005.205  
 Video RE  
 TURN MOVEMENT COUNT

File Name : TH-41 at Hazeltine Blvd 2013  
 Site Code :  
 Start Date : 11/20/2013  
 Page No : 3

Start Time	TH-41 Southbound					Hazeltine Blvd Westbound					TH-41 Northbound					Hazeltine Blvd Eastbound					Int. Total
	Right	Thru	Left	Peds	App. Total	Right	Thru	Left	Peds	App. Total	Right	Thru	Left	Peds	App. Total	Right	Thru	Left	Peds	App. Total	
16:30	1	207	34	0	242	20	1	18	0	39	20	120	3	0	143	0	0	2	0	2	426
16:45	1	188	28	0	217	27	0	15	0	42	23	127	2	0	152	0	1	2	0	3	414
17:00	7	175	33	0	215	30	2	24	0	56	14	129	7	0	150	1	0	1	0	2	423
17:15	3	215	49	0	267	18	0	18	0	36	16	109	3	0	128	0	1	1	0	2	433
Total Volume	12	785	144	0	941	95	3	75	0	173	73	485	15	0	573	1	2	6	0	9	1696
% App. Total	1.3	83.4	15.3	0		54.9	1.7	43.4	0		12.7	84.6	2.6	0		11.1	22.2	66.7	0		
PHF	.429	.913	.735	.000	.881	.792	.375	.781	.000	.772	.793	.940	.536	.000	.942	.250	.500	.750	.000	.750	.979

Peak Hour Analysis From 15:00 to 17:45 - Peak 1 of 1  
 Peak Hour for Entire Intersection Begins at 16:30

