

Albeck Gerken, Inc

Transportation Engineers

Traffic Data Collection

TH-47 / University Ave at 37th Ave NE

Ref.Pt.: 005.371

Data by: Albeck Gerken Inc

TURN MOVEMENT COUNT

File Name : TH-47 at 37th Ave NE

Site Code : 01828111

Start Date : 7/10/2008

Page No : 1

Groups Printed- Unshifted

| Start Time | TH-47 / University Ave Southbound | | | | 37th Ave NE Westbound | | | | TH-47 / University Ave Northbound | | | | 37th Ave NE Eastbound | | | | Int. Total |
|--------------------|-----------------------------------|-------------|------------|-----------|-----------------------|------------|------------|----------|-----------------------------------|-------------|------------|-----------|-----------------------|------------|------------|----------|--------------|
| | Left | Thru | Right | Peds | Left | Thru | Right | Peds | Left | Thru | Right | Peds | Left | Thru | Right | Peds | |
| 06:00 | 15 | 131 | 4 | 0 | 11 | 0 | 7 | 0 | 0 | 23 | 1 | 0 | 3 | 6 | 9 | 0 | 210 |
| 06:15 | 15 | 176 | 6 | 0 | 15 | 6 | 9 | 0 | 1 | 27 | 3 | 1 | 5 | 3 | 6 | 0 | 273 |
| 06:30 | 28 | 197 | 7 | 1 | 23 | 4 | 16 | 1 | 1 | 48 | 8 | 2 | 8 | 5 | 7 | 1 | 357 |
| 06:45 | 33 | 271 | 17 | 0 | 20 | 6 | 6 | 1 | 0 | 43 | 6 | 2 | 5 | 10 | 8 | 1 | 429 |
| Total | 91 | 775 | 34 | 1 | 69 | 16 | 38 | 2 | 2 | 141 | 18 | 5 | 21 | 24 | 30 | 2 | 1269 |
| 07:00 | 13 | 249 | 9 | 0 | 30 | 6 | 8 | 0 | 4 | 39 | 4 | 3 | 7 | 8 | 5 | 0 | 385 |
| 07:15 | 19 | 280 | 5 | 1 | 38 | 7 | 15 | 0 | 3 | 47 | 5 | 1 | 7 | 0 | 9 | 0 | 437 |
| 07:30 | 23 | 301 | 7 | 0 | 35 | 7 | 21 | 0 | 2 | 59 | 7 | 0 | 8 | 6 | 9 | 0 | 485 |
| 07:45 | 24 | 289 | 12 | 0 | 28 | 6 | 15 | 1 | 0 | 71 | 8 | 5 | 9 | 4 | 8 | 0 | 480 |
| Total | 79 | 1119 | 33 | 1 | 131 | 26 | 59 | 1 | 9 | 216 | 24 | 9 | 31 | 18 | 31 | 0 | 1787 |
| 08:00 | 18 | 192 | 7 | 1 | 41 | 6 | 18 | 0 | 0 | 49 | 8 | 1 | 6 | 6 | 6 | 1 | 360 |
| 08:15 | 16 | 216 | 8 | 0 | 38 | 2 | 18 | 0 | 1 | 63 | 9 | 0 | 11 | 4 | 5 | 1 | 392 |
| 08:30 | 14 | 148 | 4 | 0 | 27 | 3 | 11 | 0 | 0 | 52 | 8 | 2 | 4 | 7 | 4 | 2 | 286 |
| 08:45 | 14 | 154 | 8 | 0 | 24 | 4 | 15 | 0 | 0 | 70 | 5 | 0 | 5 | 8 | 4 | 1 | 312 |
| Total | 62 | 710 | 27 | 1 | 130 | 15 | 62 | 0 | 1 | 234 | 30 | 3 | 26 | 25 | 19 | 5 | 1350 |
| *** BREAK *** | | | | | | | | | | | | | | | | | |
| 11:00 | 18 | 72 | 4 | 0 | 13 | 4 | 11 | 0 | 2 | 78 | 15 | 3 | 8 | 5 | 4 | 0 | 237 |
| 11:15 | 6 | 80 | 9 | 1 | 16 | 7 | 12 | 1 | 1 | 61 | 9 | 0 | 5 | 6 | 3 | 0 | 217 |
| 11:30 | 11 | 77 | 4 | 0 | 20 | 4 | 14 | 0 | 3 | 78 | 21 | 3 | 9 | 2 | 2 | 0 | 248 |
| 11:45 | 11 | 73 | 4 | 0 | 15 | 11 | 14 | 0 | 2 | 84 | 11 | 2 | 10 | 5 | 2 | 0 | 244 |
| Total | 46 | 302 | 21 | 1 | 64 | 26 | 51 | 1 | 8 | 301 | 56 | 8 | 32 | 18 | 11 | 0 | 946 |
| 12:00 | 13 | 77 | 7 | 1 | 17 | 13 | 25 | 0 | 5 | 93 | 9 | 4 | 6 | 6 | 4 | 0 | 280 |
| 12:15 | 22 | 91 | 12 | 0 | 11 | 7 | 12 | 0 | 9 | 87 | 12 | 5 | 9 | 6 | 5 | 0 | 288 |
| 12:30 | 18 | 92 | 10 | 2 | 16 | 6 | 19 | 0 | 6 | 89 | 15 | 7 | 4 | 11 | 3 | 0 | 298 |
| 12:45 | 24 | 95 | 7 | 0 | 24 | 7 | 19 | 0 | 5 | 82 | 12 | 4 | 7 | 5 | 9 | 0 | 300 |
| Total | 77 | 355 | 36 | 3 | 68 | 33 | 75 | 0 | 25 | 351 | 48 | 20 | 26 | 28 | 21 | 0 | 1166 |
| *** BREAK *** | | | | | | | | | | | | | | | | | |
| 15:00 | 15 | 94 | 8 | 0 | 14 | 10 | 22 | 0 | 4 | 145 | 17 | 0 | 5 | 7 | 1 | 0 | 342 |
| 15:15 | 15 | 87 | 10 | 0 | 15 | 9 | 20 | 0 | 5 | 138 | 17 | 0 | 15 | 11 | 5 | 0 | 347 |
| 15:30 | 27 | 108 | 5 | 0 | 10 | 13 | 26 | 0 | 9 | 194 | 19 | 7 | 11 | 0 | 4 | 0 | 433 |
| 15:45 | 28 | 87 | 10 | 0 | 12 | 7 | 32 | 1 | 7 | 206 | 21 | 0 | 12 | 9 | 2 | 0 | 434 |
| Total | 85 | 376 | 33 | 0 | 51 | 39 | 100 | 1 | 25 | 683 | 74 | 7 | 43 | 27 | 12 | 0 | 1556 |
| 16:00 | 26 | 98 | 9 | 0 | 14 | 13 | 26 | 1 | 6 | 245 | 16 | 0 | 4 | 7 | 4 | 0 | 469 |
| 16:15 | 47 | 80 | 8 | 1 | 16 | 14 | 22 | 1 | 5 | 249 | 16 | 2 | 14 | 12 | 4 | 0 | 491 |
| 16:30 | 19 | 80 | 21 | 1 | 18 | 12 | 28 | 0 | 4 | 323 | 23 | 0 | 21 | 10 | 4 | 0 | 564 |
| 16:45 | 24 | 94 | 10 | 0 | 14 | 22 | 29 | 0 | 8 | 291 | 32 | 4 | 12 | 10 | 3 | 0 | 553 |
| Total | 116 | 352 | 48 | 2 | 62 | 61 | 105 | 2 | 23 | 1108 | 87 | 6 | 51 | 39 | 15 | 0 | 2077 |
| 17:00 | 30 | 92 | 7 | 2 | 13 | 12 | 23 | 0 | 10 | 286 | 30 | 3 | 14 | 13 | 3 | 0 | 538 |
| 17:15 | 27 | 85 | 8 | 0 | 17 | 7 | 31 | 1 | 4 | 289 | 28 | 1 | 10 | 7 | 1 | 0 | 516 |
| 17:30 | 21 | 70 | 4 | 2 | 14 | 15 | 25 | 0 | 3 | 214 | 26 | 5 | 16 | 8 | 1 | 0 | 424 |
| 17:45 | 28 | 78 | 11 | 0 | 9 | 12 | 22 | 1 | 7 | 190 | 20 | 0 | 5 | 8 | 2 | 0 | 393 |
| Total | 106 | 325 | 30 | 4 | 53 | 46 | 101 | 2 | 24 | 979 | 104 | 9 | 45 | 36 | 7 | 0 | 1871 |
| Grand Total | 662 | 4314 | 262 | 13 | 628 | 262 | 591 | 9 | 117 | 4013 | 441 | 67 | 275 | 215 | 146 | 7 | 12022 |
| Apprch % | 12.6 | 82.2 | 5 | 0.2 | 42.1 | 17.6 | 39.7 | 0.6 | 2.5 | 86.5 | 9.5 | 1.4 | 42.8 | 33.4 | 22.7 | 1.1 | |
| Total % | 5.5 | 35.9 | 2.2 | 0.1 | 5.2 | 2.2 | 4.9 | 0.1 | 1 | 33.4 | 3.7 | 0.6 | 2.3 | 1.8 | 1.2 | 0.1 | |

Albeck Gerken, Inc

Transportation Engineers

Traffic Data Collection

TH-47 / University Ave at 37th Ave NE

Ref.Pt.: 005.371

Data by: Albeck Gerken Inc

TURN MOVEMENT COUNT

File Name : TH-47 at 37th Ave NE

Site Code : 01828111

Start Date : 7/10/2008

Page No : 2

| Start Time | TH-47 / University Ave Southbound | | | | | 37th Ave NE Westbound | | | | | TH-47 / University Ave Northbound | | | | | 37th Ave NE Eastbound | | | | | Int. Total |
|--|-----------------------------------|------|-------|------|------------|-----------------------|------|-------|------|------------|-----------------------------------|------|-------|------|------------|-----------------------|------|-------|------|------------|------------|
| | Left | Thru | Right | Peds | App. Total | Left | Thru | Right | Peds | App. Total | Left | Thru | Right | Peds | App. Total | Left | Thru | Right | Peds | App. Total | |
| Peak Hour Analysis From 06:00 to 08:45 - Peak 1 of 1 | | | | | | | | | | | | | | | | | | | | | |
| Peak Hour for Entire Intersection Begins at 07:00 | | | | | | | | | | | | | | | | | | | | | |
| 07:00 | 13 | 249 | 9 | 0 | 271 | 30 | 6 | 8 | 0 | 44 | 4 | 39 | 4 | 3 | 50 | 7 | 8 | 5 | 0 | 20 | 385 |
| 07:15 | 19 | 280 | 5 | 1 | 305 | 38 | 7 | 15 | 0 | 60 | 3 | 47 | 5 | 1 | 56 | 7 | 0 | 9 | 0 | 16 | 437 |
| 07:30 | 23 | 301 | 7 | 0 | 331 | 35 | 7 | 21 | 0 | 63 | 2 | 59 | 7 | 0 | 68 | 8 | 6 | 9 | 0 | 23 | 485 |
| 07:45 | 24 | 289 | 12 | 0 | 325 | 28 | 6 | 15 | 1 | 50 | 0 | 71 | 8 | 5 | 84 | 9 | 4 | 8 | 0 | 21 | 480 |
| Total Volume | 79 | 1119 | 33 | 1 | 1232 | 131 | 26 | 59 | 1 | 217 | 9 | 216 | 24 | 9 | 258 | 31 | 18 | 31 | 0 | 80 | 1787 |
| % App. Total | 6.4 | 90.8 | 2.7 | 0.1 | | 60.4 | 12 | 27.2 | 0.5 | | 3.5 | 83.7 | 9.3 | 3.5 | | 38.8 | 22.5 | 38.8 | 0 | | |
| PHF | .823 | .929 | .688 | .250 | .931 | .862 | .929 | .702 | .250 | .861 | .563 | .761 | .750 | .450 | .768 | .861 | .563 | .861 | .000 | .870 | .921 |

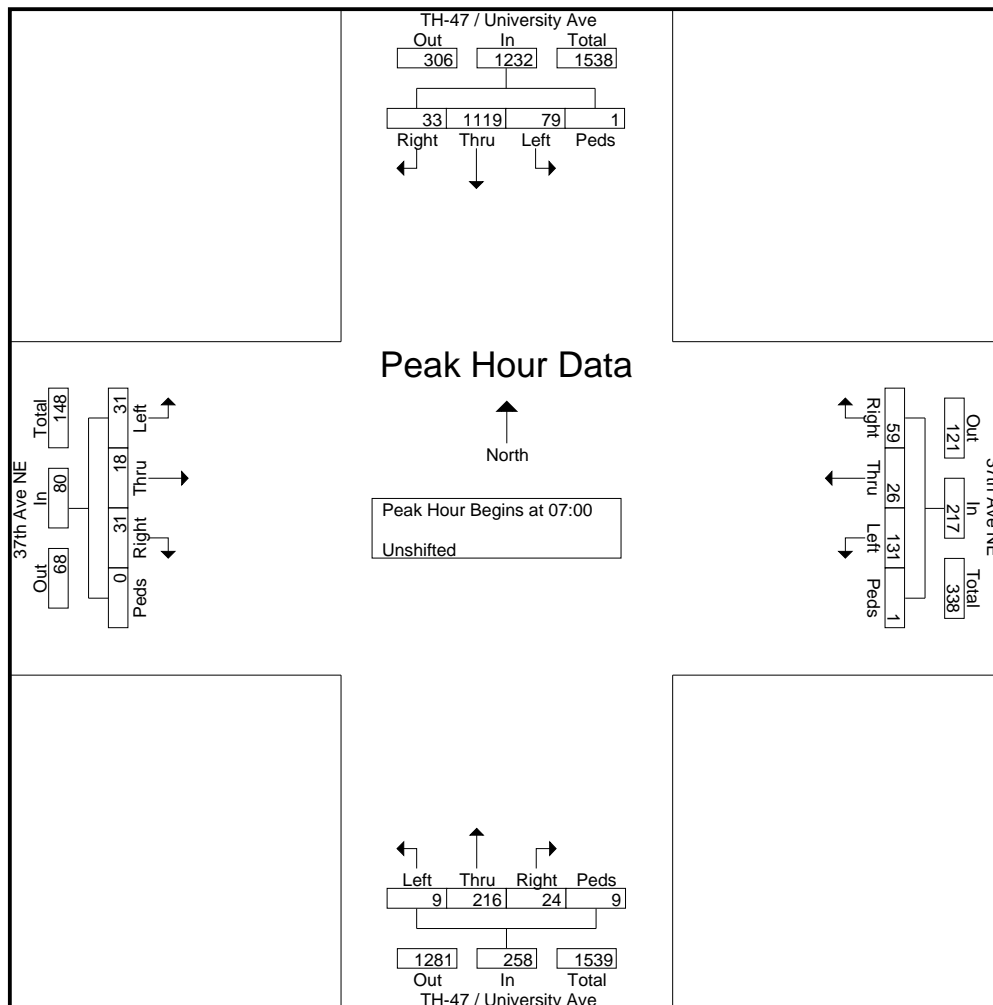

Albeck Gerken, Inc

Transportation Engineers

Traffic Data Collection

TH-47 / University Ave at 37th Ave NE

Ref.Pt.: 005.371

Data by: Albeck Gerken Inc

TURN MOVEMENT COUNT

File Name : TH-47 at 37th Ave NE

Site Code : 01828111

Start Date : 7/10/2008

Page No : 3

| Start Time | TH-47 / University Ave Southbound | | | | | 37th Ave NE Westbound | | | | | TH-47 / University Ave Northbound | | | | | 37th Ave NE Eastbound | | | | | Int. Total |
|--|-----------------------------------|------|-------|------|------------|-----------------------|------|-------|------|------------|-----------------------------------|------|-------|------|------------|-----------------------|------|-------|------|------------|------------|
| | Left | Thru | Right | Peds | App. Total | Left | Thru | Right | Peds | App. Total | Left | Thru | Right | Peds | App. Total | Left | Thru | Right | Peds | App. Total | |
| Peak Hour Analysis From 15:00 to 17:45 - Peak 1 of 1 | | | | | | | | | | | | | | | | | | | | | |
| Peak Hour for Entire Intersection Begins at 16:30 | | | | | | | | | | | | | | | | | | | | | |
| 16:30 | 19 | 80 | 21 | 1 | 121 | 18 | 12 | 28 | 0 | 58 | 4 | 323 | 23 | 0 | 350 | 21 | 10 | 4 | 0 | 35 | 564 |
| 16:45 | 24 | 94 | 10 | 0 | 128 | 14 | 22 | 29 | 0 | 65 | 8 | 291 | 32 | 4 | 335 | 12 | 10 | 3 | 0 | 25 | 553 |
| 17:00 | 30 | 92 | 7 | 2 | 131 | 13 | 12 | 23 | 0 | 48 | 10 | 286 | 30 | 3 | 329 | 14 | 13 | 3 | 0 | 30 | 538 |
| 17:15 | 27 | 85 | 8 | 0 | 120 | 17 | 7 | 31 | 1 | 56 | 4 | 289 | 28 | 1 | 322 | 10 | 7 | 1 | 0 | 18 | 516 |
| Total Volume | 100 | 351 | 46 | 3 | 500 | 62 | 53 | 111 | 1 | 227 | 26 | 1189 | 113 | 8 | 1336 | 57 | 40 | 11 | 0 | 108 | 2171 |
| % App. Total | 20 | 70.2 | 9.2 | 0.6 | | 27.3 | 23.3 | 48.9 | 0.4 | | 1.9 | 89 | 8.5 | 0.6 | | 52.8 | 37 | 10.2 | 0 | | |
| PHF | .833 | .934 | .548 | .375 | .954 | .861 | .602 | .895 | .250 | .873 | .650 | .920 | .883 | .500 | .954 | .679 | .769 | .688 | .000 | .771 | .962 |

