

ALLIANT ENGINEERING, INC.

733 S Marquette Ave #700, Minneapolis, MN 55402

Intersection: 44th Avenue & University Avenue
 Date: 3/19/2024
 Duration: 0600-1800

Site Code: 6031
 Ref Pt: N/A
 Page No: 2 of 4

All Vehicles (Cars & Trucks) Printed

Start Time	University Avenue Southbound						44th Avenue Westbound						University Avenue Northbound						44th Avenue Eastbound						Int. Veh. Total	Int. Ped/Bike Total
	U-Turn	Left	Thru	Right	App. Total	Peds/Bikes	U-Turn	Left	Thru	Right	App. Total	Peds/Bikes	U-Turn	Left	Thru	Right	App. Total	Peds/Bikes	U-Turn	Left	Thru	Right	App. Total	Peds/Bikes		
7:00	--	--	--	5	5	--	--	2	60	1	63	--	--	2	1	1	4	--	--	1	42	31	74	--	146	--
7:15	--	1	1	3	5	1	--	4	83	2	89	--	--	1	--	1	2	1	--	2	48	29	79	--	175	2
7:30	--	1	1	3	5	1	--	1	87	1	89	1	--	2	2	2	6	1	--	2	30	20	52	--	152	3
7:45	--	--	1	6	7	1	--	3	83	5	91	--	--	3	--	2	5	--	--	3	37	10	50	--	153	1
Hour Total	--	2	3	17	22	3	--	10	313	9	332	1	--	8	3	6	17	2	--	8	157	90	255	--	626	6
% of App.	0.0%	9.1%	13.6%	77.3%			0.0%	3.0%	94.3%	2.7%			0.0%	47.1%	17.6%	35.3%			0.0%	3.1%	61.6%	35.3%				
% of Total	0.0%	0.3%	0.5%	2.7%	3.5%	50.0%	0.0%	1.6%	50.0%	1.4%	53.0%	16.7%	0.0%	1.3%	0.5%	1.0%	2.7%	33.3%	0.0%	1.3%	25.1%	14.4%	40.7%	0.0%		
Cars Total	--	1	2	17	20	3	--	8	295	7	310	1	--	8	3	5	16	2	--	8	147	80	235	--	581	6
Cars % of Movement	0.0%	50.0%	66.7%	100%	90.9%	50.0%	0.0%	80.0%	94.2%	77.8%	93.4%	16.7%	0.0%	100%	100%	83.3%	94.1%	33.3%	0.0%	100%	93.6%	88.9%	92.2%	0.0%	92.8%	
Trucks Total	--	1	1	--	2	--	--	2	18	2	22	--	--	--	--	1	1	--	--	--	10	10	20	--	45	--
Trucks % of Movement	0.0%	50.0%	33.3%	0.0%	9.1%	--	0.0%	20.0%	5.8%	22.2%	6.6%	--	0.0%	0.0%	0.0%	16.7%	5.9%	--	0.0%	0.0%	6.4%	11.1%	7.8%	--	7.2%	

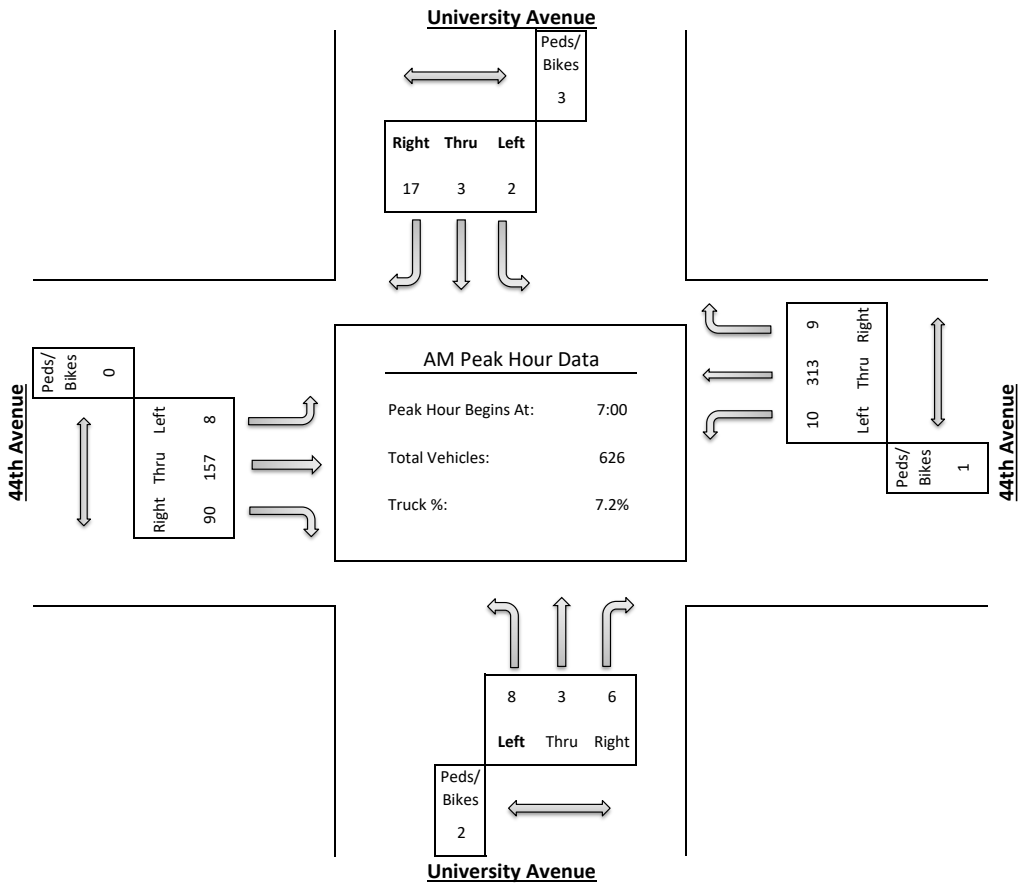

ALLIANT ENGINEERING, INC.

733 S Marquette Ave #700, Minneapolis, MN 55402

Intersection: 44th Avenue & University Avenue
 Date: 3/19/2024
 Duration: 0600-1800

Site Code: 6031
 Ref Pt: N/A
 Page No: 3 of 4

All Vehicles (Cars & Trucks) Printed

Start Time	University Avenue Southbound						44th Avenue Westbound						University Avenue Northbound						44th Avenue Eastbound						Int. Veh. Total	Int. Ped/Bike Total
	U-Turn	Left	Thru	Right	App. Total	Peds/Bikes	U-Turn	Left	Thru	Right	App. Total	Peds/Bikes	U-Turn	Left	Thru	Right	App. Total	Peds/Bikes	U-Turn	Left	Thru	Right	App. Total	Peds/Bikes		
12:30	--	4	3	1	8	--	--	--	28	2	30	--	--	1	--	--	1	--	--	2	33	5	40	--	79	--
12:45	--	1	3	1	5	--	--	1	39	4	44	--	--	2	--	--	2	--	--	2	39	8	49	--	100	--
13:00	--	--	1	2	3	--	--	--	56	1	57	--	--	3	1	1	5	--	--	4	32	2	38	--	103	--
13:15	--	--	1	3	4	--	--	--	44	1	45	--	--	2	1	--	3	--	--	1	51	1	53	--	105	--
Hour Total	--	5	8	7	20	--	--	1	167	8	176	--	--	8	2	1	11	--	--	9	155	16	180	--	387	--
% of App.	0.0%	25.0%	40.0%	35.0%			0.0%	0.6%	94.9%	4.5%			0.0%	72.7%	18.2%	9.1%			0.0%	5.0%	86.1%	8.9%				
% of Total	0.0%	1.3%	2.1%	1.8%	5.2%	--	0.0%	0.3%	43.2%	2.1%	45.5%	--	0.0%	2.1%	0.5%	0.3%	2.8%	--	0.0%	2.3%	40.1%	4.1%	46.5%	--		
Cars Total	--	4	8	7	19	--	--	1	165	7	173	--	--	7	2	1	10	--	--	9	152	16	177	--	379	--
Cars % of Movement	0.0%	80.0%	100%	100%	95.0%	--	0.0%	100%	98.8%	87.5%	98.3%	--	0.0%	87.5%	100%	100%	90.9%	--	0.0%	100%	98.1%	100%	98.3%	--	97.9%	--
Trucks Total	--	1	--	--	1	--	--	--	2	1	3	--	--	1	--	--	1	--	--	--	3	--	3	--	8	--
Trucks % of Movement	0.0%	20.0%	0.0%	0.0%	5.0%	--	0.0%	0.0%	1.2%	12.5%	1.7%	--	0.0%	12.5%	0.0%	0.0%	9.1%	--	0.0%	0.0%	1.9%	0.0%	1.7%	--	2.1%	--

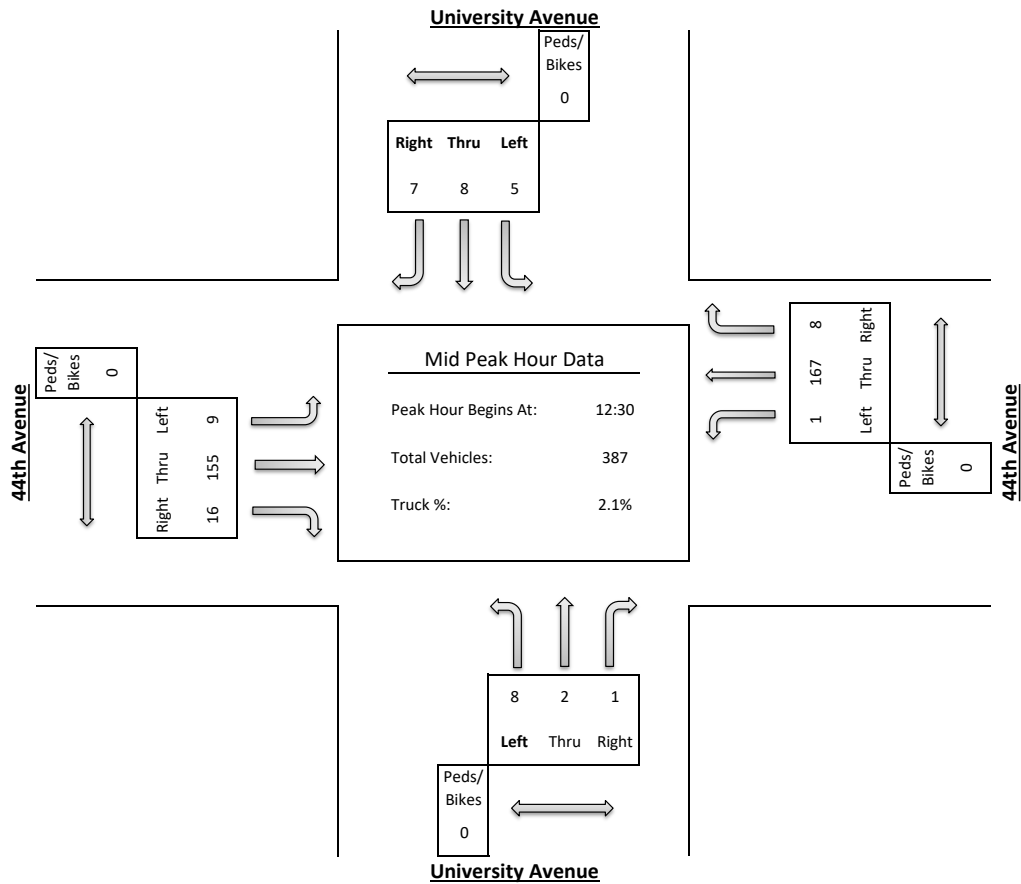

ALLIANT ENGINEERING, INC.

733 S Marquette Ave #700, Minneapolis, MN 55402

Intersection: 44th Avenue & University Avenue
 Date: 3/19/2024
 Duration: 0600-1800

Site Code: 6031
 Ref Pt: N/A
 Page No: 4 of 4

All Vehicles (Cars & Trucks) Printed

Start Time	University Avenue Southbound						44th Avenue Westbound						University Avenue Northbound						44th Avenue Eastbound						Int. Veh. Total	Int. Ped/Bike Total
	U-Turn	Left	Thru	Right	App. Total	Peds/Bikes	U-Turn	Left	Thru	Right	App. Total	Peds/Bikes	U-Turn	Left	Thru	Right	App. Total	Peds/Bikes	U-Turn	Left	Thru	Right	App. Total	Peds/Bikes		
15:15	--	--	--	5	5	1	--	--	84	--	84	1	--	3	1	--	4	--	--	4	85	4	93	--	186	2
15:30	--	4	1	7	12	--	--	--	80	5	85	--	--	6	--	2	8	1	--	5	97	2	104	--	209	1
15:45	--	2	--	5	7	1	--	--	62	1	63	4	--	2	--	--	2	--	--	6	85	4	95	--	167	5
16:00	--	--	--	5	5	--	--	1	63	3	67	--	--	4	1	1	6	--	--	1	78	5	84	--	162	--
Hour Total	--	6	1	22	29	2	--	1	289	9	299	5	--	15	2	3	20	1	--	16	345	15	376	--	724	8
% of App.	0.0%	20.7%	3.4%	75.9%			0.0%	0.3%	96.7%	3.0%			0.0%	75.0%	10.0%	15.0%			0.0%	4.3%	91.8%	4.0%				
% of Total	0.0%	0.8%	0.1%	3.0%	4.0%	25.0%	0.0%	0.1%	39.9%	1.2%	41.3%	62.5%	0.0%	2.1%	0.3%	0.4%	2.8%	12.5%	0.0%	2.2%	47.7%	2.1%	51.9%	0.0%		
Cars Total	--	5	1	21	27	2	--	1	284	9	294	5	--	15	2	3	20	1	--	16	344	15	375	--	716	8
Cars % of Movement	0.0%	83.3%	100%	95.5%	93.1%	25.0%	0.0%	100%	98.3%	100%	98.3%	62.5%	0.0%	100%	100%	100%	100%	12.5%	0.0%	100%	99.7%	100%	99.7%	0.0%	98.9%	
Trucks Total	--	1	--	1	2	--	--	--	5	--	5	--	--	--	--	--	0	--	--	--	1	--	1	--	8	--
Trucks % of Movement	0.0%	16.7%	0.0%	4.5%	6.9%	--	0.0%	0.0%	1.7%	0.0%	1.7%	--	0.0%	0.0%	0.0%	0.0%	0.0%	--	0.0%	0.0%	0.3%	0.0%	0.3%	--	1.1%	

