

ALLIANT ENGINEERING, INC.

733 S Marquette Ave #700, Minneapolis, MN 55402

Intersection: 61st Avenue & University Service Road
 Date: 3/19/2024
 Duration: 0600-1800

Site Code: 6091
 Ref Pt: N/A
 Page No: 1 of 4

All Vehicles (Cars & Trucks) Printed

Start Time	University Service Road Southbound						61st Avenue Westbound						Cielo Apartment Access Northbound						61st Avenue Eastbound						Int. Veh. Total	Int. Ped/Bike Total
	U-Turn	Left	Thru	Right	App. Total	Peds/Bikes	U-Turn	Left	Thru	Right	App. Total	Peds/Bikes	U-Turn	Left	Thru	Right	App. Total	Peds/Bikes	U-Turn	Left	Thru	Right	App. Total	Peds/Bikes		
6:00	--	--	--	--	0	--	--	--	12	--	12	--	--	5	--	--	5	--	--	4	6	1	11	--	28	--
6:15	--	--	1	--	1	--	--	--	9	--	9	--	--	3	--	--	3	--	--	5	7	2	14	--	27	--
6:30	--	--	--	1	1	--	--	1	20	--	21	1	--	4	--	1	5	1	--	8	15	1	24	--	51	2
6:45	--	--	--	--	0	--	--	1	21	--	22	--	--	7	--	1	8	--	--	9	22	4	35	--	65	--
Hour Total	--	--	1	1	2	--	--	2	62	--	64	1	--	19	--	2	21	1	--	26	50	8	84	--	171	2
7:00	--	--	--	2	2	--	--	1	26	--	27	--	--	6	--	2	8	1	--	9	31	3	43	--	80	1
7:15	1	--	--	3	4	--	--	--	31	2	33	--	--	1	--	--	1	1	--	15	54	3	72	--	110	1
7:30	--	--	--	3	3	--	--	--	42	--	42	--	--	7	--	1	8	--	--	7	64	1	72	--	125	--
7:45	--	--	--	2	2	--	--	1	75	1	77	2	--	5	--	--	5	1	1	11	80	2	94	--	178	3
Hour Total	1	--	--	10	11	--	--	2	174	3	179	2	--	19	--	3	22	3	1	42	229	9	281	--	493	5
8:00	--	1	--	3	4	--	--	2	47	1	50	--	--	5	--	2	7	1	--	12	55	2	69	--	130	1
8:15	--	--	--	6	6	--	--	1	49	7	57	--	--	2	--	--	2	--	--	10	56	3	69	--	134	--
8:30	--	--	--	4	4	--	--	--	33	--	33	--	--	4	--	--	4	2	--	2	37	4	43	--	84	2
8:45	--	2	--	15	17	--	--	--	18	2	20	--	1	6	--	--	7	1	--	21	32	1	54	--	98	1
Hour Total	--	3	--	28	31	--	--	3	147	10	160	--	1	17	--	2	20	4	--	45	180	10	235	--	446	4
9:00	1	2	--	9	12	--	--	--	31	--	31	--	--	6	--	--	6	--	1	17	29	8	55	--	104	--
9:15	--	--	--	2	2	--	--	--	30	1	31	--	--	6	--	--	6	--	--	17	22	3	42	--	81	--
9:30	--	5	--	12	17	--	--	--	20	2	22	--	--	2	--	--	2	--	--	21	19	3	43	--	84	--
9:45	--	1	--	9	10	1	--	--	31	--	31	--	--	--	--	1	1	--	--	11	19	2	32	--	74	1
Hour Total	1	8	--	32	41	1	--	--	112	3	115	--	--	14	--	1	15	--	1	66	89	16	172	--	343	1
10:00	--	4	--	12	16	--	--	--	16	1	17	--	--	4	--	1	5	--	--	9	22	2	33	--	71	--
10:15	--	1	--	17	18	--	--	--	19	--	19	--	--	1	--	1	2	--	--	6	20	3	29	--	68	--
10:30	--	1	--	13	14	1	--	--	21	--	21	--	--	1	--	--	1	--	--	17	28	--	45	--	81	1
10:45	--	--	--	7	7	--	--	1	27	2	30	--	--	4	--	--	4	--	--	18	28	2	48	--	89	--
Hour Total	--	6	--	49	55	1	--	1	83	3	87	--	--	10	--	2	12	--	--	50	98	7	155	--	309	1
11:00	--	3	--	5	8	--	--	--	38	--	38	--	--	2	--	1	3	--	--	10	22	3	35	--	84	--
11:15	--	1	--	11	12	3	--	--	24	1	25	--	--	3	1	1	5	--	--	12	23	2	37	--	79	3
11:30	--	2	--	5	7	1	--	1	17	--	18	--	--	3	--	--	3	--	--	10	23	5	38	--	66	1
11:45	--	1	--	7	8	--	--	1	19	--	20	--	--	1	--	--	1	1	--	16	21	1	38	--	67	1
Hour Total	--	7	--	28	35	4	--	2	98	1	101	--	--	9	1	2	12	1	--	48	89	11	148	--	296	5
12:00	--	--	--	12	12	--	--	--	44	--	44	--	--	5	--	1	6	1	--	13	25	3	41	--	103	1
12:15	--	--	--	16	16	--	--	--	27	--	27	--	--	2	1	1	4	--	--	14	23	3	40	--	87	--
12:30	--	--	--	10	10	--	--	--	21	1	22	--	--	6	--	1	7	1	--	14	18	4	36	--	75	1
12:45	--	1	--	10	11	--	--	--	14	3	17	--	--	7	--	1	8	1	--	16	39	9	64	--	100	1
Hour Total	--	1	--	48	49	--	--	--	106	4	110	--	--	20	1	4	25	3	--	57	105	19	181	--	365	3
13:00	--	3	--	16	19	1	--	--	32	2	34	--	--	4	--	--	4	--	--	22	32	2	56	--	113	1
13:15	--	1	--	18	19	--	--	--	34	1	35	--	--	4	--	--	4	--	--	12	24	6	42	--	100	--
13:30	--	2	--	13	15	--	--	1	22	3	26	--	--	5	--	2	7	2	--	14	27	6	47	--	95	2
13:45	--	--	--	7	7	2	--	--	27	1	28	--	--	4	--	--	4	2	--	9	36	3	48	1	87	5
Hour Total	--	6	--	54	60	3	--	1	115	7	123	--	--	17	--	2	19	4	--	57	119	17	193	1	395	8
14:00	--	--	--	8	8	1	--	--	23	2	25	--	--	6	--	1	7	1	--	11	29	4	44	--	84	2
14:15	--	1	--	9	10	--	--	--	26	2	28	--	--	3	--	1	4	--	--	19	30	3	52	--	94	--
14:30	--	1	--	9	10	--	--	1	29	1	31	--	--	3	--	--	3	--	--	8	47	7	62	--	106	--
14:45	--	2	--	5	7	--	--	2	40	1	43	--	--	8	--	1	9	--	--	11	69	7	87	--	146	--
Hour Total	--	4	--	31	35	1	--	3	118	6	127	--	--	20	--	3	23	1	--	49	175	21	245	--	430	2
15:00	--	3	--	10	13	--	--	2	78	1	81	--	--	5	--	1	6	5	--	9	44	7	60	--	160	5
15:15	--	--	--	18	18	--	--	1	66	--	67	--	--	3	--	--	3	5	--	14	35	11	60	--	148	5
15:30	--	1	--	9	10	1	--	--	40	3	43	--	--	5	--	3	8	3	1	14	40	4	59	--	120	4
15:45	--	4	--	18	22	--	--	--	45	2	47	--	--	4	--	1	5	2	--	14	43	4	61	--	135	2
Hour Total	--	8	--	55	63	1	--	3	229	6	238	--	--	17	--	5	22	15	1	51	162	26	240	--	563	16
16:00	--	--	--	20	20	--	--	--	49	1	50	--	--	3	1	1	5	2	--	12	44	6	62	--	137	2
16:15	--	1	--	9	10	--	--	--	38	1	39	--	--	4	--	2	6	2	--	9	43	2	54	--	109	2
16:30	--	3	--	14	17	--	--	--	37	1	38	--	--	1	--	1	2	1	--	11	49	8	68	--	125	1
16:45	--	1	--	5	6	--	--	--	53	--	53	1	--	3	--	1	4	3	--	5	29	10	44	--	107	4
Hour Total	--	5	--	48	53	--	--	--	177	3	180	1	--	11	1	5	17	8	--	37	165	26	228	--	478	9
17:00	--	2	--	12	14	1	--	--	25	--	25	--	--	5	--	--	5	4	--	7	52	8	67	--	111	5
17:15	--	--	--	10	10	1	--	2	29	1	32	--	--	4	--	--	1	5	--	6	47	3	56	--	103	1
17:30	--	--	--	13	13	--	1	--	45	--	46	--	--	4	--	1	5	4	1	5	47	9	62	--	126	4
17:45	--	1	--	7	8	--	--	1	31	--	32	--	--	6	--	2	8	--	--	8	33	6	47	--	95	--
Hour Total	--	3	--	42	45	2	1	3	130	1	135	--	--	19	--	4	23	8	1	26	179	26	232	--	435	10
Grand Total	2	51	1	426	480	13	1	20	1551	47	1619	4	1	192	3	35	231	48	4	554	1640	196	2394	1	4724	66
% of App.	0.4%	10.6%	0.2%	88.8%			0.1%	1.2%	95.8%	2.9%			0.4%	83.1%	1.3%	15.2%			0.2%	23.1%	68.5%	8.2%				
% of Total	0.0%	1.1%	0.0%	9.0%	10.2%	19.7%	0.0%	0.4%	32.8%	1.0%	34.3%	6.1%	0.0%	4.1%	0.1%	0.7%	4.9%	72.7%	0.1%	11.7%	34.7%	4.1%	50.7%	1.5%		
Cars Total	2	47	--	402	451	13	1	18	1486	44	1549	4	1	189	3	35	228	47	3	531	1587	194	2315	1	4543	65
Cars % of Movement	100%	92.2%	0.0%	94.4%	94.0%	20.0%	100%	90.0%	95.8%	93.6%	95.7%	6.2%	100%	98.4%	100%	100%	98.7%	72.3%	75.0%	95.8%	96.8%	99.0%	96.7%	1.5%	96.2%	
Trucks Total	--	4	1	24	29	--	--	2	65	3	70	--	--	3	--	--	3	1	1	23	53	2	79	--	181	1
Trucks % of Movement	0.0%	7.8%	100%	5.6%	6.0%	0.0%	0.0%	10.0%	4.2%	6.4%	4.3%	0.0%	0.0%	1.6%	0.0%	0.0%	1.3%	#####	25.0%	4.2%	3.2%	1.0%	3.3%	0.0%	3.8%	

ALLIANT ENGINEERING, INC.

733 S Marquette Ave #700, Minneapolis, MN 55402

Intersection: 61st Avenue & University Service Road
 Date: 3/19/2024
 Duration: 0600-1800

Site Code: 6091
 Ref Pt: N/A
 Page No: 2 of 4

All Vehicles (Cars & Trucks) Printed

Start Time	University Service Road Southbound						61st Avenue Westbound						Cielo Apartment Access Northbound						61st Avenue Eastbound						Int. Veh. Total	Int. Ped/Bike Total
	U-Turn	Left	Thru	Right	App. Total	Peds/Bikes	U-Turn	Left	Thru	Right	App. Total	Peds/Bikes	U-Turn	Left	Thru	Right	App. Total	Peds/Bikes	U-Turn	Left	Thru	Right	App. Total	Peds/Bikes		
7:30	--	--	--	3	3	--	--	--	42	--	42	--	--	7	--	1	8	--	--	7	64	1	72	--	125	--
7:45	--	--	--	2	2	--	--	1	75	1	77	2	--	5	--	--	5	1	1	11	80	2	94	--	178	3
8:00	--	1	--	3	4	--	--	2	47	1	50	--	--	5	--	2	7	1	--	12	55	2	69	--	130	1
8:15	--	--	--	6	6	--	--	1	49	7	57	--	--	2	--	--	2	--	--	10	56	3	69	--	134	--
Hour Total	--	1	--	14	15	--	--	4	213	9	226	2	--	19	--	3	22	2	1	40	255	8	304	--	567	4
% of App.	0.0%	6.7%	0.0%	93.3%			0.0%	1.8%	94.2%	4.0%			0.0%	86.4%	0.0%	13.6%			0.3%	13.2%	83.9%	2.6%				
% of Total	0.0%	0.2%	0.0%	2.5%	2.6%	0.0%	0.0%	0.7%	37.6%	1.6%	39.9%	50.0%	0.0%	3.4%	0.0%	0.5%	3.9%	50.0%	0.2%	7.1%	45.0%	1.4%	53.6%	0.0%		
Cars Total	--	--	--	14	14	--	--	4	202	9	215	2	--	19	--	3	22	2	1	40	249	8	298	--	549	4
Cars % of Movement	0.0%	0.0%	0.0%	100%	93.3%	0.0%	0.0%	100%	94.8%	100%	95.1%	50.0%	0.0%	100%	0.0%	100%	100%	50.0%	100%	100%	97.6%	100%	98.0%	0.0%	96.8%	
Trucks Total	--	1	--	--	1	--	--	--	11	--	11	--	--	--	--	--	0	--	--	--	6	--	6	--	18	--
Trucks % of Movement	0.0%	100%	0.0%	0.0%	6.7%	--	0.0%	0.0%	5.2%	0.0%	4.9%	--	0.0%	0.0%	0.0%	0.0%	0.0%	--	0.0%	0.0%	2.4%	0.0%	2.0%	--	3.2%	

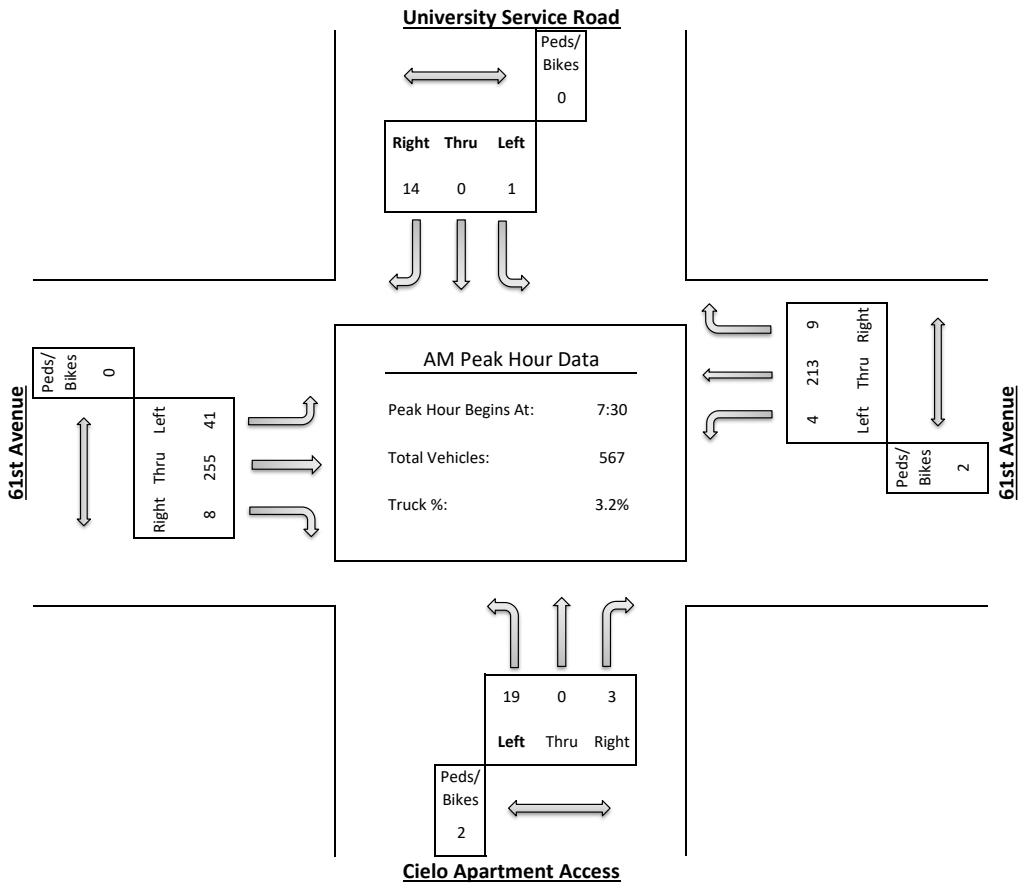

ALLIANT ENGINEERING, INC.

733 S Marquette Ave #700, Minneapolis, MN 55402

Intersection: 61st Avenue & University Service Road
 Date: 3/19/2024
 Duration: 0600-1800

Site Code: 6091
 Ref Pt: N/A
 Page No: 3 of 4

All Vehicles (Cars & Trucks) Printed

Start Time	University Service Road Southbound						61st Avenue Westbound						Cielo Apartment Access Northbound						61st Avenue Eastbound						Int. Veh. Total	Int. Ped/Bike Total
	U-Turn	Left	Thru	Right	App. Total	Peds/Bikes	U-Turn	Left	Thru	Right	App. Total	Peds/Bikes	U-Turn	Left	Thru	Right	App. Total	Peds/Bikes	U-Turn	Left	Thru	Right	App. Total	Peds/Bikes		
12:30	--	--	--	10	10	--	--	--	21	1	22	--	--	6	--	1	7	1	--	14	18	4	36	--	75	1
12:45	--	1	--	10	11	--	--	--	14	3	17	--	--	7	--	1	8	1	--	16	39	9	64	--	100	1
13:00	--	3	--	16	19	1	--	--	32	2	34	--	--	4	--	--	4	--	--	22	32	2	56	--	113	1
13:15	--	1	--	18	19	--	--	--	34	1	35	--	--	4	--	--	4	--	--	12	24	6	42	--	100	--
Hour Total	--	5	--	54	59	1	--	--	101	7	108	--	--	21	--	2	23	2	--	64	113	21	198	--	388	3
% of App.	0.0%	8.5%	0.0%	91.5%			0.0%	0.0%	93.5%	6.5%			0.0%	91.3%	0.0%	8.7%			0.0%	32.3%	57.1%	10.6%				
% of Total	0.0%	1.3%	0.0%	13.9%	15.2%	33.3%	0.0%	0.0%	26.0%	1.8%	27.8%	0.0%	0.0%	5.4%	0.0%	0.5%	5.9%	66.7%	0.0%	16.5%	29.1%	5.4%	51.0%	0.0%		
Cars Total	--	5	--	51	56	1	--	--	95	7	102	--	--	21	--	2	23	2	--	61	110	21	192	--	373	3
Cars % of Movement	0.0%	100%	0.0%	94.4%	94.9%	33.3%	0.0%	0.0%	94.1%	100%	94.4%	0.0%	0.0%	100%	0.0%	100%	100%	66.7%	0.0%	95.3%	97.3%	100%	97.0%	0.0%	96.1%	
Trucks Total	--	--	--	3	3	--	--	--	6	--	6	--	--	--	--	--	0	--	--	3	3	--	6	--	15	--
Trucks % of Movement	0.0%	0.0%	0.0%	5.6%	5.1%	--	0.0%	0.0%	5.9%	0.0%	5.6%	--	0.0%	0.0%	0.0%	0.0%	0.0%	--	0.0%	4.7%	2.7%	0.0%	3.0%	--	3.9%	

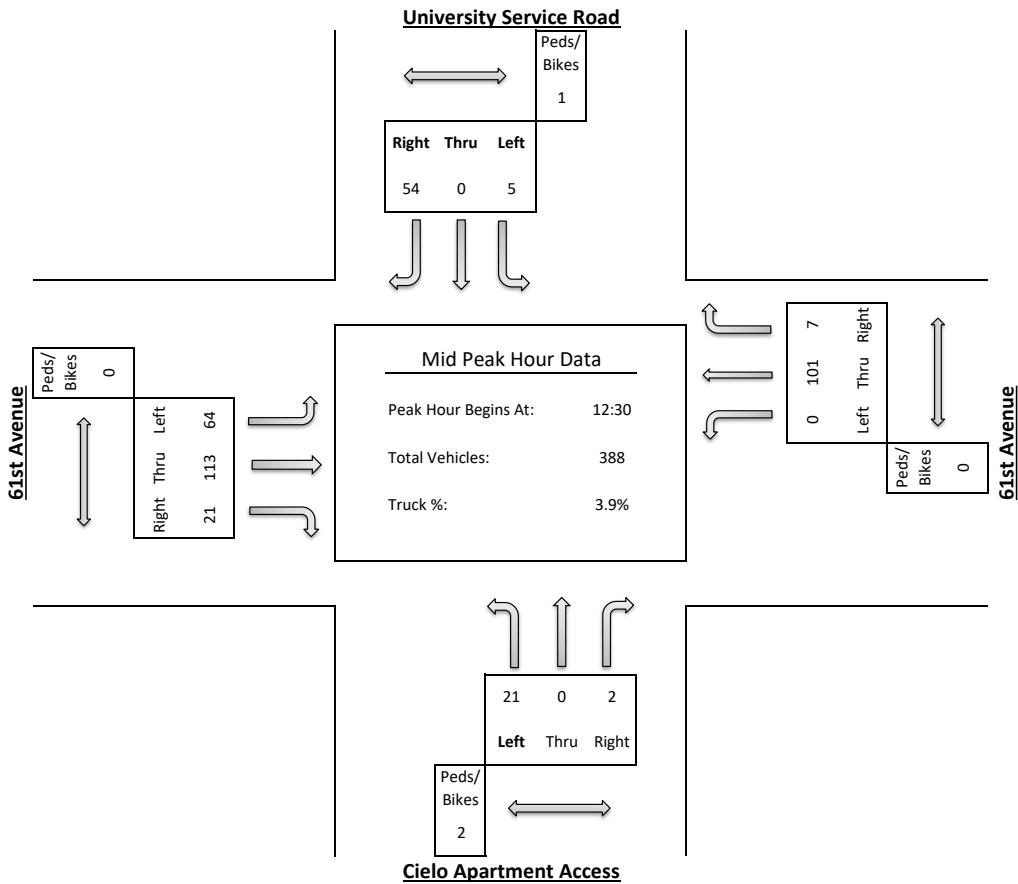

ALLIANT ENGINEERING, INC.

733 S Marquette Ave #700, Minneapolis, MN 55402

Intersection: 61st Avenue & University Service Road
 Date: 3/19/2024
 Duration: 0600-1800

Site Code: 6091
 Ref Pt: N/A
 Page No: 4 of 4

All Vehicles (Cars & Trucks) Printed

Start Time	University Service Road Southbound						61st Avenue Westbound						Cielo Apartment Access Northbound						61st Avenue Eastbound						Int. Veh. Total	Int. Ped/Bike Total
	U-Turn	Left	Thru	Right	App. Total	Peds/Bikes	U-Turn	Left	Thru	Right	App. Total	Peds/Bikes	U-Turn	Left	Thru	Right	App. Total	Peds/Bikes	U-Turn	Left	Thru	Right	App. Total	Peds/Bikes		
14:45	--	2	--	5	7	--	--	2	40	1	43	--	--	8	--	1	9	--	--	11	69	7	87	--	146	--
15:00	--	3	--	10	13	--	--	2	78	1	81	--	--	5	--	1	6	5	--	9	44	7	60	--	160	5
15:15	--	--	--	18	18	--	--	1	66	--	67	--	--	3	--	--	3	5	--	14	35	11	60	--	148	5
15:30	--	1	--	9	10	1	--	--	40	3	43	--	--	5	--	3	8	3	1	14	40	4	59	--	120	4
Hour Total	--	6	--	42	48	1	--	5	224	5	234	--	--	21	--	5	26	13	1	48	188	29	266	--	574	14
% of App.	0.0%	12.5%	0.0%	87.5%			0.0%	2.1%	95.7%	2.1%			0.0%	80.8%	0.0%	19.2%		0.4%	18.0%	70.7%	10.9%					
% of Total	0.0%	1.0%	0.0%	7.3%	8.4%	7.1%	0.0%	0.9%	39.0%	0.9%	40.8%	0.0%	0.0%	3.7%	0.0%	0.9%	4.5%	92.9%	0.2%	8.4%	32.8%	5.1%	46.3%	0.0%		
Cars Total	--	6	--	42	48	1	--	4	214	4	222	--	--	20	--	5	25	12	--	48	178	28	254	--	549	13
Cars % of Movement	0.0%	100%	0.0%	100%	100%	7.7%	0.0%	80.0%	95.5%	80.0%	94.9%	0.0%	0.0%	95.2%	0.0%	100%	96.2%	92.3%	0.0%	100%	94.7%	96.6%	95.5%	0.0%	95.6%	
Trucks Total	--	--	--	--	0	--	--	1	10	1	12	--	--	1	--	--	1	1	1	--	10	1	12	--	25	1
Trucks % of Movement	0.0%	0.0%	0.0%	0.0%	0.0%	0.0%	0.0%	20.0%	4.5%	20.0%	5.1%	0.0%	0.0%	4.8%	0.0%	0.0%	3.8%	#####	100%	0.0%	5.3%	3.4%	4.5%	0.0%	4.4%	

