

# ALLIANT ENGINEERING, INC.

733 S Marquette Ave #700, Minneapolis, MN 55402

Intersection: TH 47 & 61st Avenue  
 Date: 3/19/2024  
 Duration: 0600-1800

Site Code: 609  
 Ref Pt: N/A  
 Page No: 1 of 4

All Vehicles (Cars & Trucks) Printed

Start Time	TH 47 Southbound						61st Avenue Westbound						TH 47 Northbound						61st Avenue Eastbound						Int. Veh. Total	Int. Ped/ Bike Total
	U-Turn	Left	Thru	Right	App. Total	Peds/ Bikes	U-Turn	Left	Thru	Right	App. Total	Peds/ Bikes	U-Turn	Left	Thru	Right	App. Total	Peds/ Bikes	U-Turn	Left	Thru	Right	App. Total	Peds/ Bikes		
6:00	--	4	125	2	131	--	--	11	1	6	18	--	--	2	91	6	99	--	--	12	1	6	19	--	267	--
6:15	1	2	152	19	174	--	--	6	3	2	11	--	--	1	80	11	92	--	--	5	2	7	14	--	291	--
6:30	--	5	211	12	228	--	--	18	5	3	26	--	--	1	103	18	122	--	--	7	1	14	22	--	398	--
6:45	--	7	177	17	201	--	--	17	5	6	28	--	--	1	177	24	202	--	--	8	3	9	20	--	451	--
Hour Total	1	18	665	50	734	--	--	52	14	17	83	--	--	5	451	59	515	--	--	32	7	36	75	--	1407	--
7:00	--	11	179	14	204	1	--	24	4	6	34	--	--	3	148	29	180	--	--	5	4	12	21	--	439	1
7:15	--	14	213	9	236	1	--	23	3	6	32	--	--	3	160	51	214	--	--	11	8	11	30	--	512	1
7:30	1	22	270	15	308	--	--	34	6	11	51	--	--	5	220	43	268	1	--	10	23	19	52	1	679	2
7:45	1	17	258	15	291	--	--	43	11	25	79	--	--	6	230	59	295	--	--	16	14	14	44	--	709	--
Hour Total	2	64	920	53	1039	2	--	124	24	48	196	--	--	17	758	182	957	1	--	42	49	56	147	1	2339	4
8:00	1	17	221	19	258	1	--	23	7	27	57	1	--	5	207	34	246	--	--	6	17	8	31	--	592	2
8:15	--	24	227	13	264	--	--	31	10	19	60	--	--	--	177	38	215	--	--	5	10	3	18	--	557	--
8:30	--	10	189	7	206	--	--	28	4	8	40	--	1	2	186	26	215	1	--	14	7	8	29	--	490	1
8:45	--	11	156	7	174	--	--	23	3	15	41	--	--	3	204	37	244	1	--	11	7	12	30	--	489	1
Hour Total	1	62	793	46	902	1	--	105	24	69	198	1	1	10	774	135	920	2	--	36	41	31	108	--	2128	4
9:00	--	10	221	21	252	1	--	20	9	17	46	--	--	--	174	36	210	1	--	13	9	7	29	--	537	2
9:15	1	5	172	22	200	--	--	25	7	8	40	--	--	--	179	33	212	--	--	12	6	6	24	--	476	--
9:30	1	9	154	18	182	--	--	21	4	10	35	--	--	--	158	21	179	--	--	17	11	4	32	--	428	--
9:45	1	7	175	10	193	2	--	21	4	13	38	--	1	2	186	23	212	2	--	12	5	9	26	--	469	4
Hour Total	3	31	722	71	827	3	--	87	24	48	159	--	1	2	697	113	813	3	--	54	31	26	111	--	1910	6
10:00	--	6	179	9	194	--	--	20	3	8	31	--	1	1	140	22	164	--	--	7	5	6	18	--	407	--
10:15	--	11	156	8	175	--	--	25	6	5	36	--	1	1	189	14	205	--	--	6	4	5	15	--	431	--
10:30	1	4	175	5	185	--	--	27	4	6	37	--	--	1	179	32	212	--	--	6	9	5	20	--	454	--
10:45	2	11	188	11	212	--	--	12	9	15	36	--	2	2	171	31	206	--	--	6	7	3	16	--	470	--
Hour Total	3	32	698	33	766	--	--	84	22	34	140	--	4	5	679	99	787	--	--	25	25	19	69	--	1762	--
11:00	1	5	189	15	210	--	--	18	9	22	49	--	--	5	169	26	200	--	--	14	3	5	22	--	481	--
11:15	--	5	181	7	193	3	--	23	5	11	39	--	--	6	190	29	225	3	--	10	3	7	20	2	477	8
11:30	1	10	213	14	238	--	--	23	--	1	24	--	4	1	191	21	217	--	--	11	7	6	24	--	503	--
11:45	--	9	176	9	194	1	--	16	6	6	28	--	2	6	197	23	228	--	--	10	6	4	20	--	470	1
Hour Total	2	29	759	45	835	4	--	80	20	40	140	--	6	18	747	99	870	3	--	45	19	22	86	2	1931	9
12:00	--	14	207	14	235	--	--	36	6	20	62	--	1	3	193	21	218	--	--	12	6	4	22	--	537	--
12:15	1	10	221	6	238	--	--	36	3	7	46	--	1	3	257	21	282	--	--	6	8	3	17	--	583	--
12:30	--	7	191	10	208	--	--	16	5	16	37	--	--	8	226	23	257	1	--	13	4	8	25	--	527	1
12:45	--	17	211	9	237	--	--	21	2	5	28	--	--	3	227	40	270	--	--	13	6	8	27	--	562	--
Hour Total	1	48	830	39	918	--	--	109	16	48	173	--	2	17	903	105	1027	1	--	44	24	23	91	--	2209	1
13:00	1	11	208	21	241	1	--	29	8	13	50	--	1	6	215	37	259	--	--	11	8	5	24	--	574	1
13:15	2	7	215	12	236	1	--	29	10	19	58	1	1	3	202	28	234	2	--	11	8	6	25	1	553	5
13:30	1	12	250	14	277	2	--	24	4	10	38	--	--	4	272	29	305	--	--	13	7	5	25	--	645	2
13:45	1	12	230	12	255	--	--	28	9	3	40	--	--	5	245	32	282	3	--	7	4	7	18	--	595	3
Hour Total	5	42	903	59	1009	4	--	110	31	45	186	1	2	18	934	126	1080	5	--	42	27	23	92	1	2367	11
14:00	--	3	250	19	272	--	--	21	3	12	36	--	--	8	261	28	297	1	--	25	12	5	42	--	647	1
14:15	--	11	245	18	274	1	--	22	6	11	39	--	--	3	285	32	320	--	--	22	7	2	31	1	664	2
14:30	--	17	317	14	348	--	--	28	5	9	42	--	--	5	320	33	358	--	--	19	12	3	34	--	782	--
14:45	1	21	251	16	289	--	--	22	13	18	53	--	2	9	315	51	377	--	--	15	15	8	38	--	757	--
Hour Total	1	52	1063	67	1183	1	--	93	27	50	170	--	2	25	1181	144	1352	1	--	81	46	18	145	1	2850	3
15:00	--	8	249	26	283	--	--	45	15	31	91	--	--	7	314	42	363	2	--	24	9	4	37	--	774	2
15:15	--	11	293	31	335	--	--	39	22	30	91	--	--	8	328	41	377	4	--	20	7	7	34	--	837	4
15:30	1	9	291	27	328	1	--	31	12	14	57	--	1	13	308	34	356	1	--	37	17	8	62	--	803	2
15:45	--	15	236	24	275	1	--	33	17	19	69	--	1	10	297	33	341	2	--	21	11	6	38	--	723	3
Hour Total	1	43	1069	108	1221	2	--	148	66	94	308	--	2	38	1247	150	1437	9	--	102	44	25	171	--	3137	11
16:00	--	14	289	24	327	1	--	35	18	18	71	--	--	8	338	35	381	1	--	24	14	14	52	--	831	2
16:15	--	11	291	35	337	--	--	26	11	14	51	--	2	9	313	32	356	2	--	25	11	14	50	1	794	3
16:30	1	15	261	22	299	--	--	27	12	9	48	--	--	3	330	36	369	--	--	34	17	15	66	--	782	--
16:45	--	8	265	23	296	1	--	30	14	23	67	--	3	10	301	24	338	4	--	20	13	18	51	1	752	6
Hour Total	1	48	1106	104	1259	2	--	118	55	64	237	--	5	30	1282	127	1444	7	--	103	55	61	219	2	3159	11
17:00	--	10	272	15	297	1	--	22	13	10	45	1	--	6	293	38	337	--	--	19	19	19	57	--	736	2
17:15	2	13	261	21	297	--	--	18	14	8	40	--	--	6	282	31	319	2	--	16	12	10	38	--	694	2
17:30	--	16	221	12	249	--	--	34	9	20	63	--	--	9	322	35	366	3	--	20	10	3	33	--	711	3
17:45	--	9	241	11	261	--	--	24	9	13	46	--	--	4	244	29	277	2	--	16	8	10	34	--	618	2
Hour Total	2	48	995	59	1104	1	--	98	45	51	194	1	--	25	1141	133	1299	7	--	71	49	42	162	--	2759	9
Grand Total	23	517	10523	734	11797	20	--	1208	368	608	2184	3	25	210	10794	1472	12501	39	--	677	417	382	1476	7	27958	69

# ALLIANT ENGINEERING, INC.

733 S Marquette Ave #700, Minneapolis, MN 55402

Intersection: TH 47 & 61st Avenue  
 Date: 3/19/2024  
 Duration: 0600-1800

Site Code: 609  
 Ref Pt: N/A  
 Page No: 2 of 4

All Vehicles (Cars & Trucks) Printed

Start Time	TH 47 Southbound						61st Avenue Westbound						TH 47 Northbound						61st Avenue Eastbound						Int. Veh. Total	Int. Ped/Bike Total
	U-Turn	Left	Thru	Right	App. Total	Peds/Bikes	U-Turn	Left	Thru	Right	App. Total	Peds/Bikes	U-Turn	Left	Thru	Right	App. Total	Peds/Bikes	U-Turn	Left	Thru	Right	App. Total	Peds/Bikes		
7:30	1	22	270	15	308	--	--	34	6	11	51	--	--	5	220	43	268	1	--	10	23	19	52	1	679	2
7:45	1	17	258	15	291	--	--	43	11	25	79	--	--	6	230	59	295	--	--	16	14	14	44	--	709	--
8:00	1	17	221	19	258	1	--	23	7	27	57	1	--	5	207	34	246	--	--	6	17	8	31	--	592	2
8:15	--	24	227	13	264	--	--	31	10	19	60	--	--	--	177	38	215	--	--	5	10	3	18	--	557	--
Hour Total	3	80	976	62	1121	1	--	131	34	82	247	1	--	16	834	174	1024	1	--	37	64	44	145	1	2537	4
% of App.	0.3%	7.1%	87.1%	5.5%			0.0%	53.0%	13.8%	33.2%			0.0%	1.6%	81.4%	17.0%			0.0%	25.5%	44.1%	30.3%				
% of Total	0.1%	3.2%	38.5%	2.4%	44.2%	25.0%	0.0%	5.2%	1.3%	3.2%	9.7%	25.0%	0.0%	0.6%	32.9%	6.9%	40.4%	25.0%	0.0%	1.5%	2.5%	1.7%	5.7%	25.0%		
Cars Total	3	76	936	57	1072	1	--	128	32	76	236	1	--	16	797	165	978	1	--	34	63	44	141	1	2427	4
Cars % of Movement	100%	95.0%	95.9%	91.9%	95.6%	25.0%	0.0%	97.7%	94.1%	92.7%	95.5%	25.0%	0.0%	100%	95.6%	94.8%	95.5%	25.0%	0.0%	91.9%	98.4%	100%	97.2%	25.0%	95.7%	
Trucks Total	--	4	40	5	49	--	--	3	2	6	11	--	--	--	37	9	46	--	--	3	1	--	4	--	110	--
Trucks % of Movement	0.0%	5.0%	4.1%	8.1%	4.4%	--	0.0%	2.3%	5.9%	7.3%	4.5%	--	0.0%	0.0%	4.4%	5.2%	4.5%	--	0.0%	8.1%	1.6%	0.0%	2.8%	--	4.3%	

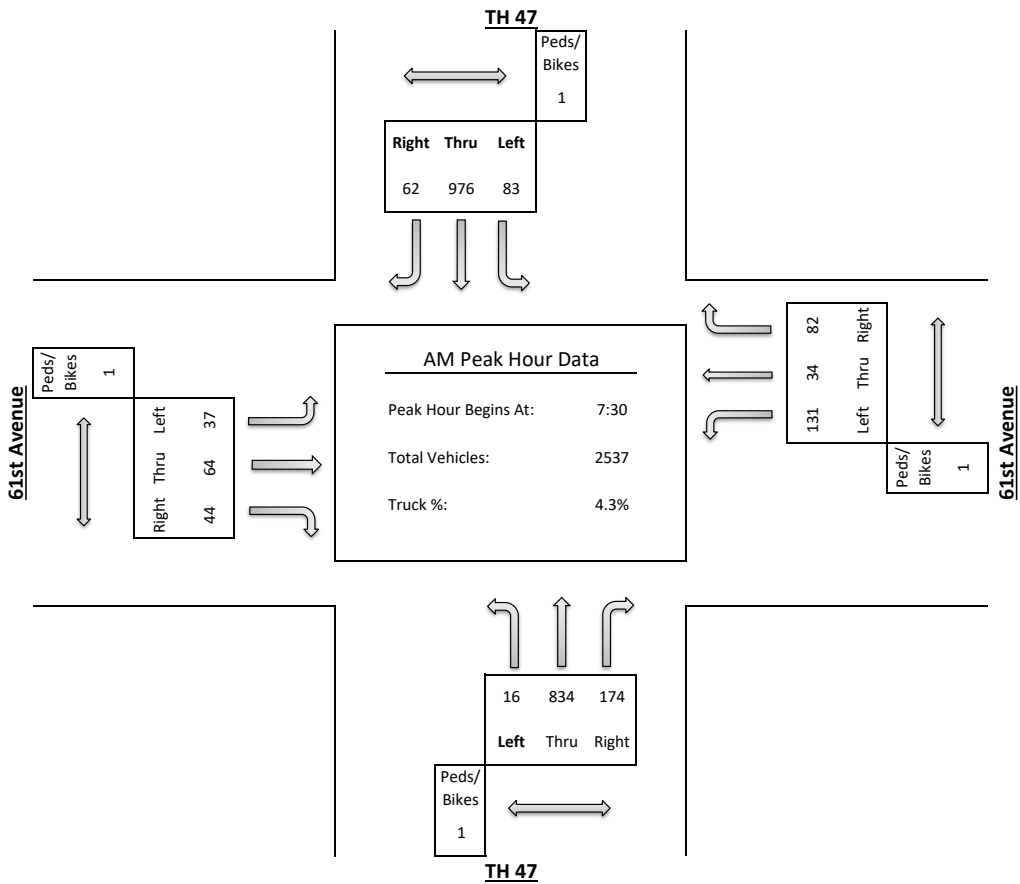

# ALLIANT ENGINEERING, INC.

733 S Marquette Ave #700, Minneapolis, MN 55402

Intersection: TH 47 & 61st Avenue  
 Date: 3/19/2024  
 Duration: 0600-1800

Site Code: 609  
 Ref Pt: N/A  
 Page No: 3 of 4

All Vehicles (Cars & Trucks) Printed

Start Time	TH 47 Southbound						61st Avenue Westbound						TH 47 Northbound						61st Avenue Eastbound						Int. Veh. Total	Int. Ped/Bike Total
	U-Turn	Left	Thru	Right	App. Total	Peds/Bikes	U-Turn	Left	Thru	Right	App. Total	Peds/Bikes	U-Turn	Left	Thru	Right	App. Total	Peds/Bikes	U-Turn	Left	Thru	Right	App. Total	Peds/Bikes		
12:15	1	10	221	6	<b>238</b>	--	--	36	3	7	<b>46</b>	--	1	3	257	21	<b>282</b>	--	--	6	8	3	<b>17</b>	--	583	--
12:30	--	7	191	10	<b>208</b>	--	--	16	5	16	<b>37</b>	--	--	8	226	23	<b>257</b>	1	--	13	4	8	<b>25</b>	--	527	1
12:45	--	17	211	9	<b>237</b>	--	--	21	2	5	<b>28</b>	--	--	3	227	40	<b>270</b>	--	--	13	6	8	<b>27</b>	--	562	--
13:00	1	11	208	21	<b>241</b>	1	--	29	8	13	<b>50</b>	--	1	6	215	37	<b>259</b>	--	--	11	8	5	<b>24</b>	--	574	1
<b>Hour Total</b>	<b>2</b>	<b>45</b>	<b>831</b>	<b>46</b>	<b>924</b>	<b>1</b>	<b>--</b>	<b>102</b>	<b>18</b>	<b>41</b>	<b>161</b>	<b>--</b>	<b>2</b>	<b>20</b>	<b>925</b>	<b>121</b>	<b>1068</b>	<b>1</b>	<b>--</b>	<b>43</b>	<b>26</b>	<b>24</b>	<b>93</b>	<b>--</b>	<b>2246</b>	<b>2</b>
% of App.	0.2%	4.9%	89.9%	5.0%			0.0%	63.4%	11.2%	25.5%			0.2%	1.9%	86.6%	11.3%			0.0%	46.2%	28.0%	25.8%				
% of Total	0.1%	2.0%	37.0%	2.0%	41.1%	50.0%	0.0%	4.5%	0.8%	1.8%	7.2%	0.0%	0.1%	0.9%	41.2%	5.4%	47.6%	50.0%	0.0%	1.9%	1.2%	1.1%	4.1%	0.0%		
Cars Total	2	44	783	43	<b>872</b>	1	--	98	18	40	<b>156</b>	--	2	19	881	116	<b>1018</b>	1	--	42	26	24	<b>92</b>	--	2138	2
Cars % of Movement	100%	97.8%	94.2%	93.5%	94.4%	50.0%	0.0%	96.1%	100%	97.6%	96.9%	0.0%	100%	95.0%	95.2%	95.9%	95.3%	50.0%	0.0%	97.7%	100%	100%	98.9%	0.0%	95.2%	
Trucks Total	--	1	48	3	<b>52</b>	--	--	4	--	1	<b>5</b>	--	--	1	44	5	<b>50</b>	--	--	1	--	--	<b>1</b>	--	108	--
Trucks % of Movement	0.0%	2.2%	5.8%	6.5%	5.6%	--	0.0%	3.9%	0.0%	2.4%	3.1%	--	0.0%	5.0%	4.8%	4.1%	4.7%	--	0.0%	2.3%	0.0%	0.0%	1.1%	--	4.8%	

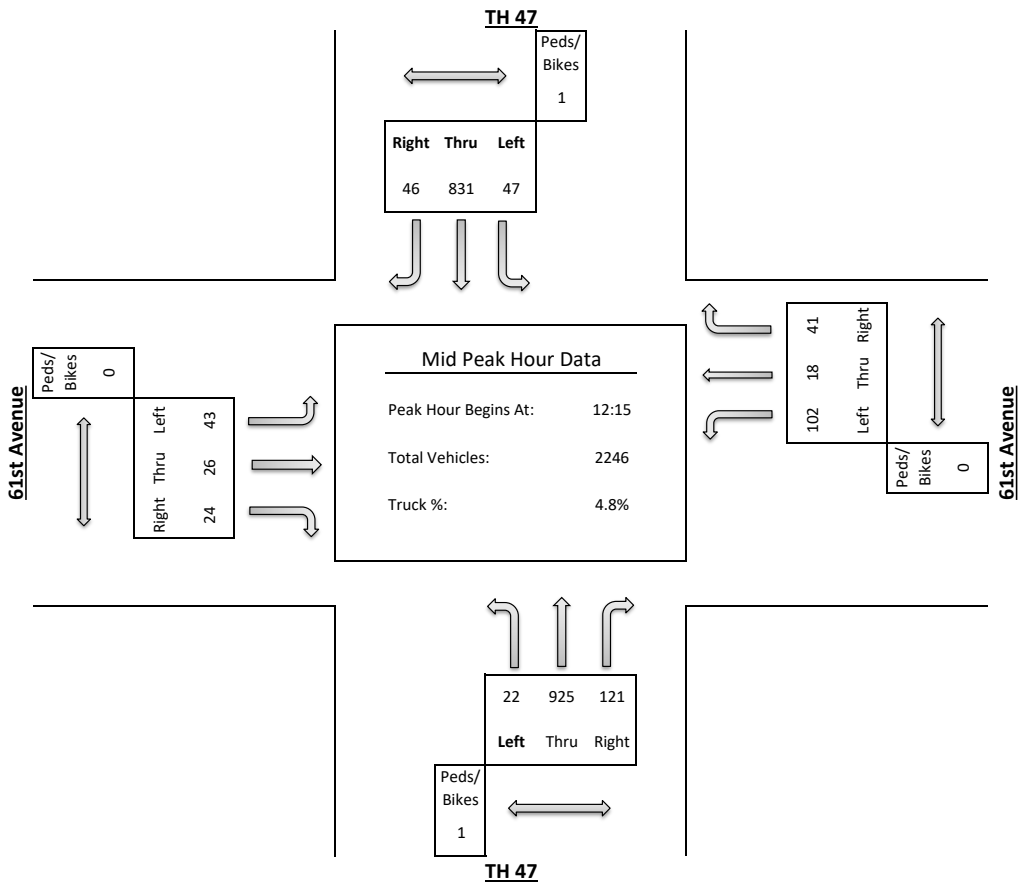

# ALLIANT ENGINEERING, INC.

733 S Marquette Ave #700, Minneapolis, MN 55402

Intersection: TH 47 & 61st Avenue  
 Date: 3/19/2024  
 Duration: 0600-1800

Site Code: 609  
 Ref Pt: N/A  
 Page No: 4 of 4

All Vehicles (Cars & Trucks) Printed

Start Time	TH 47 Southbound						61st Avenue Westbound						TH 47 Northbound						61st Avenue Eastbound						Int. Veh. Total	Int. Ped/Bike Total
	U-Turn	Left	Thru	Right	App. Total	Peds/Bikes	U-Turn	Left	Thru	Right	App. Total	Peds/Bikes	U-Turn	Left	Thru	Right	App. Total	Peds/Bikes	U-Turn	Left	Thru	Right	App. Total	Peds/Bikes		
15:15	--	11	293	31	<b>335</b>	--	--	39	22	30	<b>91</b>	--	--	8	328	41	<b>377</b>	4	--	20	7	7	<b>34</b>	--	837	4
15:30	1	9	291	27	<b>328</b>	1	--	31	12	14	<b>57</b>	--	1	13	308	34	<b>356</b>	1	--	37	17	8	<b>62</b>	--	803	2
15:45	--	15	236	24	<b>275</b>	1	--	33	17	19	<b>69</b>	--	1	10	297	33	<b>341</b>	2	--	21	11	6	<b>38</b>	--	723	3
16:00	--	14	289	24	<b>327</b>	1	--	35	18	18	<b>71</b>	--	--	8	338	35	<b>381</b>	1	--	24	14	14	<b>52</b>	--	831	2
Hour Total	1	49	1109	106	<b>1265</b>	3	--	138	69	81	<b>288</b>	--	2	39	1271	143	<b>1455</b>	8	--	102	49	35	<b>186</b>	--	3194	11
% of App.	0.1%	3.9%	87.7%	8.4%			0.0%	47.9%	24.0%	28.1%			0.1%	2.7%	87.4%	9.8%			0.0%	54.8%	26.3%	18.8%				
% of Total	0.0%	1.5%	34.7%	3.3%	39.6%	27.3%	0.0%	4.3%	2.2%	2.5%	9.0%	0.0%	0.1%	1.2%	39.8%	4.5%	45.6%	72.7%	0.0%	3.2%	1.5%	1.1%	5.8%	0.0%		
Cars Total	1	47	1082	103	<b>1233</b>	1	--	131	64	77	<b>272</b>	--	2	38	1236	140	<b>1416</b>	8	--	99	48	33	<b>180</b>	--	3101	9
Cars % of Movement	100%	95.9%	97.6%	97.2%	97.5%	11.1%	0.0%	94.9%	92.8%	95.1%	94.4%	0.0%	100%	97.4%	97.2%	97.9%	97.3%	88.9%	0.0%	97.1%	98.0%	94.3%	96.8%	0.0%	97.1%	
Trucks Total	--	2	27	3	<b>32</b>	2	--	7	5	4	<b>16</b>	--	--	1	35	3	<b>39</b>	--	--	3	1	2	<b>6</b>	--	93	2
Trucks % of Movement	0.0%	4.1%	2.4%	2.8%	2.5%	#####	0.0%	5.1%	7.2%	4.9%	5.6%	0.0%	0.0%	2.6%	2.8%	2.1%	2.7%	0.0%	0.0%	2.9%	2.0%	5.7%	3.2%	0.0%	2.9%	

