

# ALLIANT ENGINEERING, INC.

733 S Marquette Ave #700, Minneapolis, MN 55402

Intersection: Osborne Road & University Service Road  
 Date: 3/21/2024  
 Duration: 0600-1800

Site Code: 6131  
 Ref Pt: N/A  
 Page No: 1 of 4

All Vehicles (Cars & Trucks) Printed

Start Time	University Service Road Southbound						Osborne Road Westbound						University Service Road Northbound						Osborne Road Eastbound						Int. Veh. Total	Int. Ped/Bike Total	
	U-Turn	Left	Thru	Right	App. Total	Peds/Bikes	U-Turn	Left	Thru	Right	App. Total	Peds/Bikes	U-Turn	Left	Thru	Right	App. Total	Peds/Bikes	U-Turn	Left	Thru	Right	App. Total	Peds/Bikes			
6:00	--	--	--	--	0	--	--	2	32	3	37	--	--	--	--	--	0	--	--	4	17	1	22	--	59	--	
6:15	--	1	--	3	4	--	--	6	19	3	28	--	--	2	--	--	2	--	--	--	23	2	25	--	59	--	
6:30	--	--	3	1	4	--	--	1	40	6	47	--	--	3	1	2	6	--	--	1	21	2	24	--	81	--	
6:45	--	1	2	--	3	--	1	3	48	2	54	--	--	3	2	2	7	--	--	4	31	2	37	--	101	--	
Hour Total	--	2	5	4	11	--	1	12	139	14	166	--	--	8	3	4	15	--	--	9	92	7	108	--	300	--	
7:00	--	4	2	--	6	1	--	3	29	6	38	--	--	2	1	--	3	--	--	1	38	1	40	--	87	1	
7:15	--	1	1	2	4	--	--	6	43	6	55	--	--	5	2	2	9	--	--	4	41	--	45	--	113	--	
7:30	--	4	3	--	7	--	--	5	80	9	94	--	--	2	1	2	5	--	--	10	41	3	54	--	160	--	
7:45	--	3	2	1	6	--	--	5	78	12	95	--	--	1	--	--	1	--	--	7	66	5	78	--	180	--	
Hour Total	--	12	8	3	23	1	--	19	230	33	282	--	--	10	4	4	18	--	--	22	186	9	217	--	540	1	
8:00	--	4	3	4	11	--	--	7	68	14	89	--	--	1	--	3	4	--	--	4	47	2	53	1	157	1	
8:15	--	10	3	6	19	--	--	4	50	13	67	--	--	4	4	4	12	--	--	4	32	4	40	--	138	--	
8:30	--	9	6	3	18	--	--	9	51	8	68	--	--	1	3	3	7	--	--	8	48	1	57	--	150	--	
8:45	--	9	5	4	18	--	--	20	42	7	69	--	--	5	3	11	19	--	--	6	51	6	63	--	169	--	
Hour Total	--	32	17	17	66	--	--	40	211	42	293	--	--	11	10	21	42	--	--	22	178	13	213	1	614	1	
9:00	--	9	1	1	11	--	1	13	48	14	76	--	--	3	5	2	10	--	--	7	35	6	48	--	145	--	
9:15	1	15	4	4	24	--	--	18	31	13	62	--	--	7	4	9	20	--	--	4	29	6	39	--	145	--	
9:30	--	6	3	4	13	--	--	12	36	13	61	--	--	5	--	8	13	--	--	5	24	3	32	--	119	--	
9:45	--	7	4	1	12	--	--	14	28	19	61	--	--	2	2	10	14	--	--	10	43	7	60	--	147	--	
Hour Total	1	37	12	10	60	--	1	57	143	59	260	--	--	17	11	29	57	--	--	26	131	22	179	--	556	--	
10:00	--	11	6	1	18	--	1	15	42	17	75	--	--	2	7	14	23	--	--	4	30	3	37	--	153	--	
10:15	--	10	3	4	17	--	--	8	34	22	64	--	--	3	1	11	15	--	--	11	45	1	57	--	153	--	
10:30	--	13	6	2	21	--	--	6	51	19	76	--	--	5	5	8	18	--	--	7	40	4	51	--	166	--	
10:45	--	10	6	9	25	--	--	9	35	21	65	--	--	3	6	10	19	--	--	12	45	4	61	--	170	--	
Hour Total	--	44	21	16	81	--	1	38	162	79	280	--	--	13	19	43	75	--	--	34	160	12	206	--	642	--	
11:00	--	10	2	3	15	--	--	31	42	19	92	--	--	2	3	15	20	--	--	1	13	41	8	63	--	190	--
11:15	--	15	5	7	27	--	1	19	35	21	76	--	--	4	5	14	23	--	--	11	50	7	68	--	194	--	
11:30	--	14	8	4	26	1	2	14	40	28	84	--	--	4	7	18	29	--	--	7	48	5	60	--	199	1	
11:45	--	17	8	5	30	--	--	26	70	23	119	--	--	4	3	13	20	--	--	1	15	48	7	71	--	240	--
Hour Total	--	56	23	19	98	1	3	90	187	91	371	--	--	14	18	60	92	--	--	2	46	187	27	262	--	823	1
12:00	--	23	8	9	40	--	1	12	49	22	84	--	--	5	5	11	21	--	--	13	56	1	70	--	215	--	
12:15	--	17	9	6	32	--	--	17	53	23	93	--	--	5	7	11	23	--	--	1	10	47	4	62	--	210	--
12:30	--	24	3	9	36	--	1	22	46	18	87	--	--	2	2	15	19	--	--	13	53	7	73	--	215	--	
12:45	--	14	4	3	21	--	--	18	65	23	106	--	--	5	7	18	30	--	--	12	57	7	76	--	233	--	
Hour Total	--	78	24	27	129	--	2	69	213	86	370	--	--	17	21	55	93	--	--	1	48	213	19	281	--	873	--
13:00	--	12	3	12	27	--	--	20	47	13	80	--	--	6	6	11	23	1	--	12	46	3	61	--	191	1	
13:15	--	12	3	5	20	1	1	17	45	17	80	--	--	3	6	16	25	--	--	1	11	52	6	70	--	195	1
13:30	--	14	5	6	25	2	--	15	53	19	87	--	--	3	8	13	24	--	--	2	11	42	4	59	--	195	2
13:45	--	16	8	4	28	--	--	17	48	14	79	--	--	6	6	20	32	--	--	12	53	2	67	--	206	--	
Hour Total	--	54	19	27	100	3	1	69	193	63	326	--	--	18	26	60	104	1	--	3	46	193	15	257	--	787	4
14:00	--	17	8	4	29	1	1	15	49	15	80	--	--	--	8	16	24	--	--	9	59	6	74	--	207	1	
14:15	--	9	6	9	24	--	1	21	50	18	90	--	--	3	6	8	17	--	--	8	59	6	73	--	204	--	
14:30	--	13	3	6	22	--	--	20	44	27	91	--	--	6	6	12	24	--	--	10	80	4	94	--	231	--	
14:45	--	18	1	2	21	--	1	16	57	24	98	--	--	3	4	12	19	1	--	8	81	6	95	1	233	2	
Hour Total	--	57	18	21	96	1	3	72	200	84	359	--	--	12	24	48	84	1	--	35	279	22	336	1	875	3	
15:00	--	19	6	10	35	1	--	11	71	26	108	--	--	7	4	16	27	--	--	3	68	3	74	--	244	1	
15:15	--	21	4	1	26	1	--	17	69	28	114	--	--	4	2	8	14	1	--	1	11	67	10	89	--	243	2
15:30	--	13	3	5	21	--	--	6	62	14	82	--	--	5	6	12	23	--	--	12	78	3	93	--	219	--	
15:45	--	8	8	7	23	--	--	13	66	15	94	--	--	4	5	16	25	--	--	13	84	6	103	--	245	--	
Hour Total	--	61	21	23	105	2	--	47	268	83	398	--	--	20	17	52	89	1	--	1	39	297	22	359	--	951	3
16:00	--	16	5	12	33	--	1	11	89	28	129	--	--	7	5	9	21	--	--	4	84	5	93	--	276	--	
16:15	--	19	1	7	27	--	--	8	80	18	106	--	--	4	10	12	26	--	--	10	91	5	106	--	265	--	
16:30	--	17	6	9	32	--	--	11	64	15	90	--	--	2	6	13	21	--	--	11	92	9	112	--	255	--	
16:45	--	18	5	6	29	--	2	21	60	18	101	--	--	7	8	13	28	--	--	9	90	9	108	--	266	--	
Hour Total	--	70	17	34	121	--	3	51	293	79	426	--	--	20	29	47	96	--	--	34	357	28	419	--	1062	--	
17:00	--	12	5	13	30	--	--	12	74	13	99	--	--	5	4	18	27	--	--	12	75	2	89	--	245	--	
17:15	--	14	5	6	25	2	--	10	64	18	92	--	--	6	3	8	17	--	--	11	72	4	87	1	221	3	
17:30	--	11	4	4	19	--	--	10	50	16	76	--	--	2	3	5	10	--	--	7	57	4	68	--	173	--	
17:45	--	11	4	7	22	--	--	7	50	13	70	--	--	3	5	4	12	--	--	7	52	3	62	--	166	--	
Hour Total	--	48	18	30	96	2	--	39	238	60	337	--	--	16	15	35	66	--	--	37	256	13	306	1	805	3	
Grand Total	1	551	203	231	986	10	15	603	2477	773	3868	--	--	176	197	458	831	3	--	7	398	2529	209	3143	3	8828	16
% of App.	0.1%	55.9%	20.6%	23.4%			0.4%	15.6%	64.0%	20.0%			0.0%	21.2%	23.7%	55.1%			0.2%	12.7%	80.5%	6.6%					
% of Total	0.0%	6.2%	2.3%	2.6%	11.2%	62.5%	0.2%	6.8%	28.1%	8.8%	43.8%	0.0%	0.0%	2.0%	2.2%	5.2%	9.4%	18.8%	0.1%	4.5%	28.6%	2.4%	35.6%	18.8%			
Cars Total	1	543	200	229	973	8	15	602	2361	755	3733	--	--	172	196	456	824	1	--	7	394	2435	207	3043	2	8573	11
Cars % of Movement	100%	98.5%	98.5%	99.1%	98.7%	72.7%	100%	99.8%	95.3%	97.7%	96.5%	0.0%	0.0%	97.7%	9												

# ALLIANT ENGINEERING, INC.

733 S Marquette Ave #700, Minneapolis, MN 55402

Intersection: Osborne Road & University Service Road  
 Date: 3/21/2024  
 Duration: 0600-1800

Site Code: 6131  
 Ref Pt: N/A  
 Page No: 2 of 4

All Vehicles (Cars & Trucks) Printed

Start Time	University Service Road Southbound						Osborne Road Westbound						University Service Road Northbound						Osborne Road Eastbound						Int. Veh. Total	Int. Ped/Bike Total
	U-Turn	Left	Thru	Right	App. Total	Peds/Bikes	U-Turn	Left	Thru	Right	App. Total	Peds/Bikes	U-Turn	Left	Thru	Right	App. Total	Peds/Bikes	U-Turn	Left	Thru	Right	App. Total	Peds/Bikes		
7:30	--	4	3	--	7	--	--	5	80	9	94	--	--	2	1	2	5	--	--	10	41	3	54	--	160	--
7:45	--	3	2	1	6	--	--	5	78	12	95	--	--	1	--	--	1	--	--	7	66	5	78	--	180	--
8:00	--	4	3	4	11	--	--	7	68	14	89	--	--	1	--	3	4	--	--	4	47	2	53	1	157	1
8:15	--	10	3	6	19	--	--	4	50	13	67	--	--	4	4	4	12	--	--	4	32	4	40	--	138	--
Hour Total	--	21	11	11	43	--	--	21	276	48	345	--	--	8	5	9	22	--	--	25	186	14	225	1	635	1
% of App.	0.0%	48.8%	25.6%	25.6%			0.0%	6.1%	80.0%	13.9%			0.0%	36.4%	22.7%	40.9%			0.0%	11.1%	82.7%	6.2%				
% of Total	0.0%	3.3%	1.7%	1.7%	6.8%	0.0%	0.0%	3.3%	43.5%	7.6%	54.3%	0.0%	0.0%	1.3%	0.8%	1.4%	3.5%	0.0%	0.0%	3.9%	29.3%	2.2%	35.4%	#####		
Cars Total	--	21	11	11	43	--	--	21	264	48	333	--	--	7	5	9	21	--	--	25	172	14	211	1	608	1
Cars % of Movement	0.0%	100%	100%	100%	100%	0.0%	0.0%	100%	95.7%	100%	96.5%	0.0%	0.0%	87.5%	100%	100%	95.5%	0.0%	0.0%	100%	92.5%	100%	93.8%	#####	95.7%	
Trucks Total	--	--	--	--	0	--	--	--	12	--	12	--	--	1	--	--	1	--	--	--	14	--	14	--	27	--
Trucks % of Movement	0.0%	0.0%	0.0%	0.0%	0.0%	--	0.0%	0.0%	4.3%	0.0%	3.5%	--	0.0%	12.5%	0.0%	0.0%	4.5%	--	0.0%	0.0%	7.5%	0.0%	6.2%	--	4.3%	

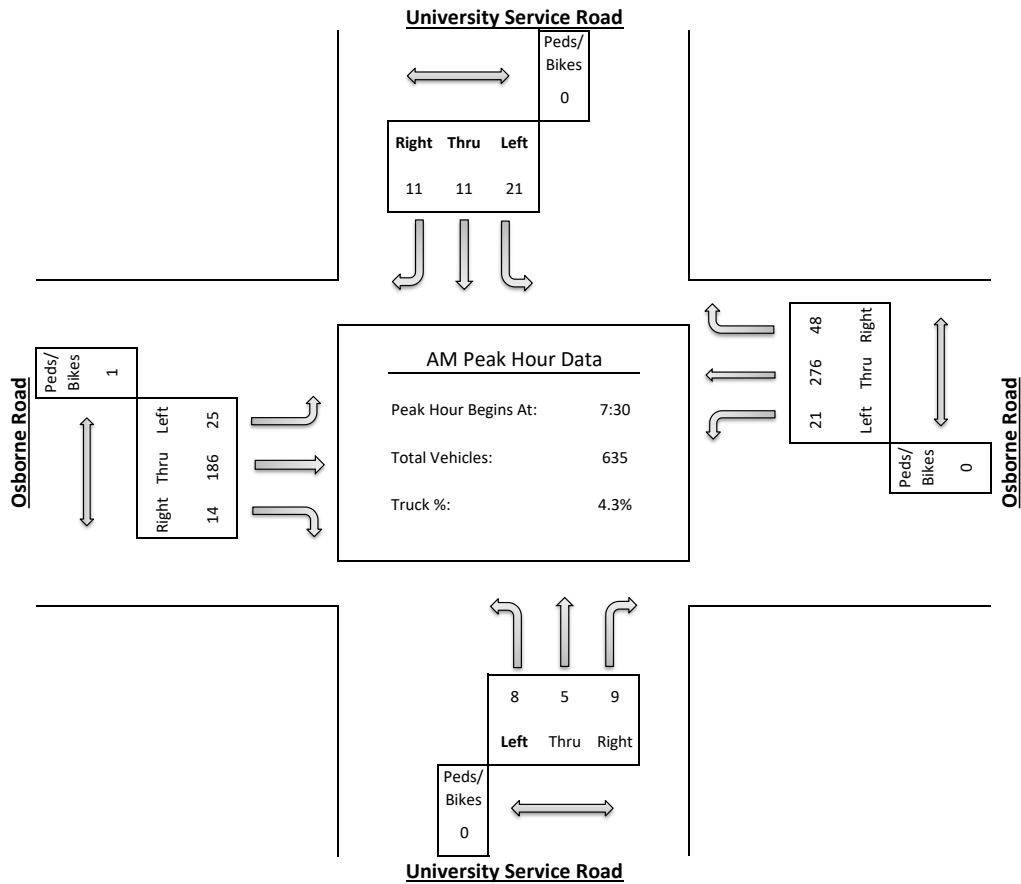

# ALLIANT ENGINEERING, INC.

733 S Marquette Ave #700, Minneapolis, MN 55402

Intersection: Osborne Road & University Service Road  
 Date: 3/21/2024  
 Duration: 0600-1800

Site Code: 6131  
 Ref Pt: N/A  
 Page No: 3 of 4

All Vehicles (Cars & Trucks) Printed

Start Time	University Service Road Southbound						Osborne Road Westbound						University Service Road Northbound						Osborne Road Eastbound						Int. Veh. Total	Int. Ped/Bike Total
	U-Turn	Left	Thru	Right	App. Total	Peds/Bikes	U-Turn	Left	Thru	Right	App. Total	Peds/Bikes	U-Turn	Left	Thru	Right	App. Total	Peds/Bikes	U-Turn	Left	Thru	Right	App. Total	Peds/Bikes		
11:45	--	17	8	5	30	--	--	26	70	23	119	--	--	4	3	13	20	--	1	15	48	7	71	--	240	--
12:00	--	23	8	9	40	--	1	12	49	22	84	--	--	5	5	11	21	--	--	13	56	1	70	--	215	--
12:15	--	17	9	6	32	--	--	17	53	23	93	--	--	5	7	11	23	--	1	10	47	4	62	--	210	--
12:30	--	24	3	9	36	--	1	22	46	18	87	--	--	2	2	15	19	--	--	13	53	7	73	--	215	--
Hour Total	--	81	28	29	138	--	2	77	218	86	383	--	--	16	17	50	83	--	2	51	204	19	276	--	880	--
% of App.	0.0%	58.7%	20.3%	21.0%			0.5%	20.1%	56.9%	22.5%			0.0%	19.3%	20.5%	60.2%			0.7%	18.5%	73.9%	6.9%				
% of Total	0.0%	9.2%	3.2%	3.3%	15.7%	--	0.2%	8.8%	24.8%	9.8%	43.5%	--	0.0%	1.8%	1.9%	5.7%	9.4%	--	0.2%	5.8%	23.2%	2.2%	31.4%	--		
Cars Total	--	78	28	28	134	--	2	77	204	84	367	--	--	15	17	50	82	--	2	51	198	19	270	--	853	--
Cars % of Movement	0.0%	96.3%	100%	96.6%	97.1%	--	100%	100%	93.6%	97.7%	95.8%	--	0.0%	93.8%	100%	100%	98.8%	--	100%	100%	97.1%	100%	97.8%	--	96.9%	--
Trucks Total	--	3	--	1	4	--	--	--	14	2	16	--	--	1	--	--	1	--	--	--	6	--	6	--	27	--
Trucks % of Movement	0.0%	3.7%	0.0%	3.4%	2.9%	--	0.0%	0.0%	6.4%	2.3%	4.2%	--	0.0%	6.3%	0.0%	0.0%	1.2%	--	0.0%	0.0%	2.9%	0.0%	2.2%	--	3.1%	--

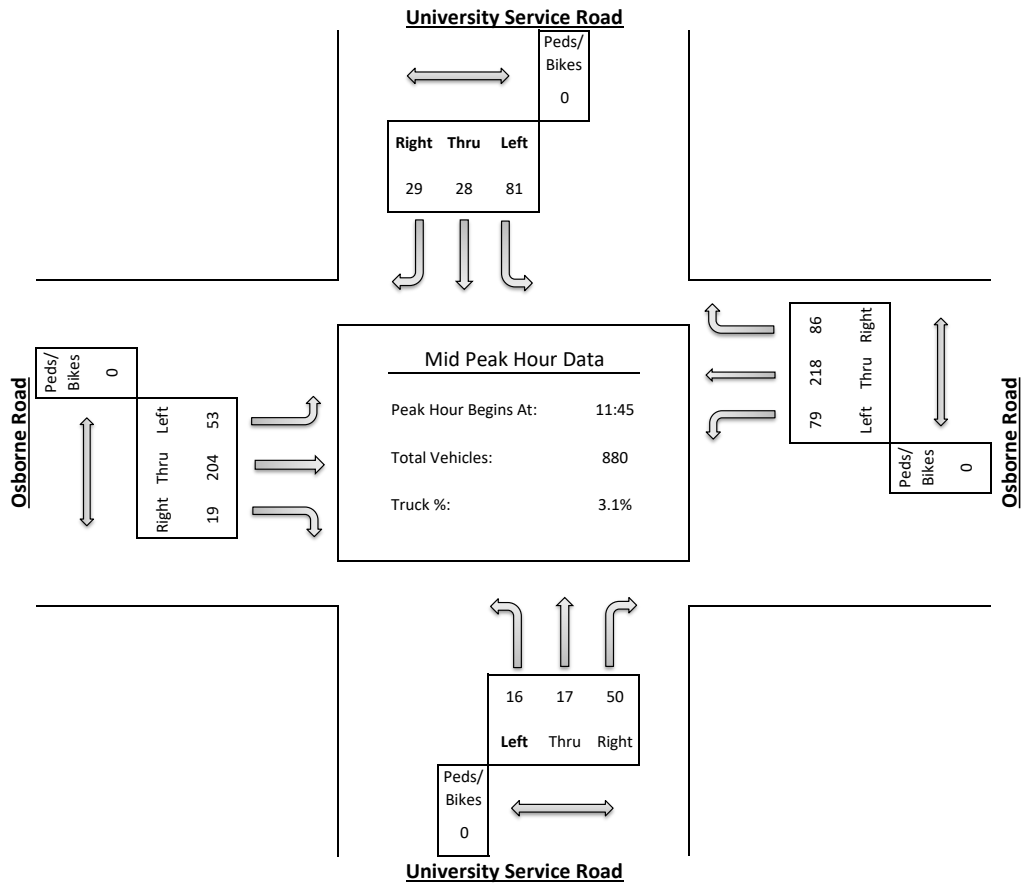

# ALLIANT ENGINEERING, INC.

733 S Marquette Ave #700, Minneapolis, MN 55402

Intersection: Osborne Road & University Service Road  
 Date: 3/21/2024  
 Duration: 0600-1800

Site Code: 6131  
 Ref Pt: N/A  
 Page No: 4 of 4

All Vehicles (Cars & Trucks) Printed

Start Time	University Service Road Southbound						Osborne Road Westbound						University Service Road Northbound						Osborne Road Eastbound						Int. Veh. Total	Int. Ped/Bike Total
	U-Turn	Left	Thru	Right	App. Total	Peds/Bikes	U-Turn	Left	Thru	Right	App. Total	Peds/Bikes	U-Turn	Left	Thru	Right	App. Total	Peds/Bikes	U-Turn	Left	Thru	Right	App. Total	Peds/Bikes		
16:00	--	16	5	12	33	--	1	11	89	28	129	--	--	7	5	9	21	--	--	4	84	5	93	--	276	--
16:15	--	19	1	7	27	--	--	8	80	18	106	--	--	4	10	12	26	--	--	10	91	5	106	--	265	--
16:30	--	17	6	9	32	--	--	11	64	15	90	--	--	2	6	13	21	--	--	11	92	9	112	--	255	--
16:45	--	18	5	6	29	--	2	21	60	18	101	--	--	7	8	13	28	--	--	9	90	9	108	--	266	--
Hour Total	--	70	17	34	121	--	3	51	293	79	426	--	--	20	29	47	96	--	--	34	357	28	419	--	1062	--
% of App.	0.0%	57.9%	14.0%	28.1%			0.7%	12.0%	68.8%	18.5%			0.0%	20.8%	30.2%	49.0%			0.0%	8.1%	85.2%	6.7%				
% of Total	0.0%	6.6%	1.6%	3.2%	11.4%	--	0.3%	4.8%	27.6%	7.4%	40.1%	--	0.0%	1.9%	2.7%	4.4%	9.0%	--	0.0%	3.2%	33.6%	2.6%	39.5%	--		
Cars Total	--	70	17	34	121	--	3	51	287	79	420	--	--	20	29	47	96	--	--	34	349	28	411	--	1048	--
Cars % of Movement	0.0%	100%	100%	100%	100%	--	100%	100%	98.0%	100%	98.6%	--	0.0%	100%	100%	100%	100%	--	0.0%	100%	97.8%	100%	98.1%	--	98.7%	--
Trucks Total	--	--	--	--	0	--	--	--	6	--	6	--	--	--	--	--	0	--	--	--	8	--	8	--	14	--
Trucks % of Movement	0.0%	0.0%	0.0%	0.0%	0.0%	--	0.0%	0.0%	2.0%	0.0%	1.4%	--	0.0%	0.0%	0.0%	0.0%	0.0%	--	0.0%	0.0%	2.2%	0.0%	1.9%	--	1.3%	--

