

ALLIANT ENGINEERING, INC.

733 S Marquette Ave #700, Minneapolis, MN 55402

Intersection: 81st Avenue & University Service Road
 Date: 3/21/2024
 Duration: 0600-1800

Site Code: 6141
 Ref Pt: N/A
 Page No: 1 of 4

All Vehicles (Cars & Trucks) Printed

Start Time	University Service Road Southbound						81st Avenue Westbound						University Service Road Northbound						81st Avenue Eastbound						Int. Veh. Total	Int. Ped/Bike Total
	U-Turn	Left	Thru	Right	App. Total	Peds/Bikes	U-Turn	Left	Thru	Right	App. Total	Peds/Bikes	U-Turn	Left	Thru	Right	App. Total	Peds/Bikes	U-Turn	Left	Thru	Right	App. Total	Peds/Bikes		
6:00	--	5	--	5	10	--	--	3	32	10	45	--	--	--	2	2	4	--	--	4	19	1	24	--	83	--
6:15	--	11	3	3	17	--	--	4	33	17	54	--	--	1	--	2	3	--	--	2	19	2	23	--	97	--
6:30	--	16	3	6	25	--	--	8	40	23	71	--	--	2	3	2	7	--	--	2	15	--	17	--	120	--
6:45	--	9	2	5	16	--	--	9	58	17	84	--	--	1	2	4	7	--	--	1	21	1	23	--	130	--
Hour Total	--	41	8	19	68	--	--	24	163	67	254	--	--	4	7	10	21	--	--	9	74	4	87	--	430	--
7:00	--	14	2	5	21	--	--	10	36	26	72	--	--	1	3	4	8	2	--	4	21	1	26	--	127	2
7:15	--	25	3	2	30	2	--	10	28	30	68	--	--	2	2	5	9	--	--	4	20	3	27	--	134	2
7:30	--	25	2	7	34	--	--	10	32	37	79	--	--	1	3	7	11	1	--	6	17	--	23	--	147	1
7:45	--	22	5	7	34	--	--	8	58	44	110	--	--	2	2	7	11	--	--	2	19	2	23	--	178	--
Hour Total	--	86	12	21	119	2	--	38	154	137	329	--	--	6	10	23	39	3	--	16	77	6	99	--	586	5
8:00	--	20	8	11	39	--	--	21	57	32	110	1	--	1	4	4	9	1	--	7	16	3	26	--	184	2
8:15	--	9	16	18	43	--	1	29	45	23	98	1	--	2	11	6	19	--	--	9	19	4	32	--	192	1
8:30	--	13	23	6	42	--	--	6	44	43	93	--	--	1	5	4	10	--	--	3	26	4	33	--	178	--
8:45	--	24	17	4	45	--	2	15	44	41	102	1	--	2	9	7	18	--	--	2	40	6	48	--	213	1
Hour Total	--	66	64	39	169	--	3	71	190	139	403	3	--	6	29	21	56	1	--	21	101	17	139	--	767	4
9:00	--	22	1	6	29	--	--	15	62	45	122	--	1	2	8	5	16	--	--	6	36	1	43	--	210	--
9:15	--	26	10	8	44	--	--	5	44	52	101	--	--	3	7	10	20	--	--	2	28	1	31	--	196	--
9:30	--	25	6	6	37	--	--	10	61	53	124	--	--	1	6	8	15	--	--	5	46	3	54	--	230	--
9:45	--	21	8	2	31	--	--	11	54	58	123	--	--	--	12	9	21	--	--	3	48	2	53	--	228	--
Hour Total	--	94	25	22	141	--	--	41	221	208	470	--	1	6	33	32	72	--	--	16	158	7	181	--	864	--
10:00	--	25	11	5	41	--	--	10	48	46	104	--	--	2	5	3	10	--	--	7	49	--	56	--	211	--
10:15	--	32	7	7	46	--	--	11	54	43	108	--	--	--	10	7	17	1	--	2	45	3	50	--	221	1
10:30	--	42	10	3	55	--	--	6	45	47	98	--	--	3	5	9	17	--	--	4	61	--	65	--	235	--
10:45	--	38	7	2	47	--	--	8	59	51	118	--	--	4	10	11	25	--	--	5	43	2	50	--	240	--
Hour Total	--	137	35	17	189	--	--	35	206	187	428	--	--	9	30	30	69	1	--	18	198	5	221	--	907	1
11:00	--	37	4	9	50	--	--	9	48	41	98	--	--	1	5	9	15	--	--	11	57	4	72	--	235	--
11:15	--	31	10	9	50	--	--	8	49	50	107	--	--	2	10	8	20	--	--	9	50	3	62	--	239	--
11:30	--	35	14	10	59	--	2	16	66	55	139	--	--	7	10	16	33	1	--	14	52	4	70	--	301	1
11:45	--	36	11	17	64	--	--	17	63	46	126	--	--	3	8	15	26	--	--	16	64	5	85	--	301	--
Hour Total	--	139	39	45	223	--	2	50	226	192	470	--	--	13	33	48	94	1	--	50	223	16	289	--	1076	1
12:00	--	33	13	13	59	--	--	12	46	58	116	--	--	8	6	14	28	--	--	7	66	7	80	--	283	--
12:15	--	40	7	9	56	--	--	10	57	58	125	--	--	2	9	21	32	--	--	9	53	6	68	--	281	--
12:30	--	41	13	12	66	1	--	17	63	63	143	--	--	2	5	15	22	--	--	15	65	2	82	--	313	1
12:45	--	49	7	9	65	--	--	6	72	49	127	--	--	2	12	12	26	--	--	11	52	3	66	--	284	--
Hour Total	--	163	40	43	246	1	--	45	238	228	511	--	--	14	32	62	108	--	--	42	236	18	296	--	1161	1
13:00	--	43	13	7	63	1	--	7	80	41	128	--	--	3	10	14	27	--	--	4	57	4	65	--	283	1
13:15	--	41	6	7	54	--	--	8	55	33	96	--	--	1	12	8	21	--	--	5	52	4	61	--	232	--
13:30	--	31	8	6	45	3	--	8	55	51	114	--	--	2	11	13	26	--	--	7	62	1	70	--	255	3
13:45	--	42	12	9	63	--	--	11	65	44	120	--	--	1	10	6	17	--	--	9	58	2	69	--	269	--
Hour Total	--	157	39	29	225	4	--	34	255	169	458	--	--	7	43	41	91	--	--	25	229	11	265	--	1039	4
14:00	--	40	7	5	52	--	--	6	61	36	103	--	--	1	12	13	26	1	--	6	76	1	83	--	264	1
14:15	--	34	12	6	52	--	--	12	66	50	128	--	--	1	7	14	22	--	--	10	56	2	68	--	270	--
14:30	--	39	6	4	49	--	--	5	61	56	122	--	--	3	19	16	38	--	--	8	76	3	87	--	296	--
14:45	--	47	8	15	70	--	--	7	49	54	110	--	--	2	9	6	17	--	--	7	69	2	78	--	275	--
Hour Total	--	160	33	30	223	--	--	30	237	196	463	--	--	7	47	49	103	1	--	31	277	8	316	--	1105	1
15:00	--	41	7	9	57	--	--	9	51	50	110	--	--	1	13	9	23	--	--	8	106	3	117	--	307	--
15:15	--	45	3	4	52	--	1	10	52	60	123	--	--	3	9	10	22	1	--	5	71	2	78	--	275	1
15:30	--	41	11	9	61	--	--	6	61	55	122	--	--	2	11	12	25	--	--	16	94	2	112	--	320	--
15:45	--	37	7	8	52	--	--	7	64	58	129	--	--	1	8	11	20	--	--	13	62	5	80	--	281	--
Hour Total	--	164	28	30	222	--	1	32	228	223	484	--	--	7	41	42	90	1	--	42	333	12	387	--	1183	1
16:00	--	46	10	6	62	--	--	4	57	46	107	--	--	1	10	10	21	--	--	10	91	3	104	--	294	--
16:15	--	50	6	3	59	--	--	9	65	45	119	--	--	7	4	13	24	1	--	10	84	--	94	--	296	1
16:30	--	39	12	6	57	--	--	4	65	50	119	--	--	3	6	5	14	1	--	8	95	3	106	--	296	1
16:45	--	48	8	4	60	--	--	8	74	50	132	--	--	6	12	10	28	--	--	10	77	4	91	--	311	--
Hour Total	--	183	36	19	238	--	--	25	261	191	477	--	--	17	32	38	87	2	--	38	347	10	395	--	1197	2
17:00	--	48	8	19	75	--	--	9	74	40	123	1	--	7	5	10	22	--	--	13	118	7	138	--	358	1
17:15	1	48	6	7	62	--	--	3	49	53	105	--	--	4	9	7	20	--	--	17	95	8	120	--	307	--
17:30	--	49	7	5	61	--	--	3	52	51	106	--	--	9	7	5	21	1	--	10	66	2	78	--	266	1
17:45	--	44	8	8	60	--	--	6	61	51	118	--	--	5	3	5	13	--	--	6	58	7	71	--	262	--
Hour Total	1	189	29	39	258	--	--	21	236	195	452	1	--	25	24	27	76	1	--	46	337	24	407	--	1193	2
Grand Total	1	1579	388	353	2321	7	6	446	2615	2132	5199	4	1	121	361	423	906	11	--	354	2590	138	3082	--	11508	22
% of App.	0.0%	68.0%	16.7%	15.2%			0.1%	8.6%	50.3%	41.0%			0.1%	13.4%	39.8%	46.7%			0.0%	11.5%	84.0%	4.5%				
% of Total	0.0%	13.7%	3.4%	3.1%	20.2%	31.8%	0.1%	3.9%	22.7%	18.5%	45.2%	18.2%	0.0%	1.1%	3.1%	3.7%	7.9%	50.0%	0.0%	3.1%	22.5%	1.2%	26.8%	0.0%		
Cars Total	1	1567	388	352	2308	7	6	435	2401	2102	4944	4	1	119	359	415	894	9	--	348	2334	133	2815	--	10961	20
Cars % of Movement	100%	99.2%	100%	99.7%	99.4%	35.0%	100%	97.5%	91.8%	98.6%	95.1%	20.0%	100%	98.3%	99.4%	98.1%	98.7%	45.0%	0.0%	98.3%	90.1%	96.4%	91.3%	0.0%	95.2%	
Trucks Total	--	12	--	1																						

ALLIANT ENGINEERING, INC.

733 S Marquette Ave #700, Minneapolis, MN 55402

Intersection: 81st Avenue & University Service Road
 Date: 3/21/2024
 Duration: 0600-1800

Site Code: 6141
 Ref Pt: N/A
 Page No: 2 of 4

All Vehicles (Cars & Trucks) Printed

Start Time	University Service Road Southbound						81st Avenue Westbound						University Service Road Northbound						81st Avenue Eastbound						Int. Veh. Total	Int. Ped/Bike Total
	U-Turn	Left	Thru	Right	App. Total	Peds/Bikes	U-Turn	Left	Thru	Right	App. Total	Peds/Bikes	U-Turn	Left	Thru	Right	App. Total	Peds/Bikes	U-Turn	Left	Thru	Right	App. Total	Peds/Bikes		
8:30	--	13	23	6	42	--	--	6	44	43	93	--	--	1	5	4	10	--	--	3	26	4	33	--	178	--
8:45	--	24	17	4	45	--	2	15	44	41	102	1	--	2	9	7	18	--	--	2	40	6	48	--	213	1
9:00	--	22	1	6	29	--	--	15	62	45	122	--	1	2	8	5	16	--	--	6	36	1	43	--	210	--
9:15	--	26	10	8	44	--	--	5	44	52	101	--	--	3	7	10	20	--	--	2	28	1	31	--	196	--
Hour Total	--	85	51	24	160	--	2	41	194	181	418	1	1	8	29	26	64	--	--	13	130	12	155	--	797	1
% of App.	0.0%	53.1%	31.9%	15.0%			0.5%	9.8%	46.4%	43.3%			1.6%	12.5%	45.3%	40.6%			0.0%	8.4%	83.9%	7.7%				
% of Total	0.0%	10.7%	6.4%	3.0%	20.1%	0.0%	0.3%	5.1%	24.3%	22.7%	52.4%	#####	0.1%	1.0%	3.6%	3.3%	8.0%	0.0%	0.0%	1.6%	16.3%	1.5%	19.4%	0.0%		
Cars Total	--	84	51	24	159	--	2	38	157	177	374	1	1	7	29	23	60	--	--	13	112	11	136	--	729	1
Cars % of Movement	0.0%	98.8%	100%	100%	99.4%	0.0%	100%	92.7%	80.9%	97.8%	89.5%	#####	100%	87.5%	100%	88.5%	93.8%	0.0%	0.0%	100%	86.2%	91.7%	87.7%	0.0%	91.5%	
Trucks Total	--	1	--	--	1	--	--	3	37	4	44	--	--	1	--	3	4	--	--	--	18	1	19	--	68	--
Trucks % of Movement	0.0%	1.2%	0.0%	0.0%	0.6%	--	0.0%	7.3%	19.1%	2.2%	10.5%	--	0.0%	12.5%	0.0%	11.5%	6.3%	--	0.0%	0.0%	13.8%	8.3%	12.3%	--	8.5%	

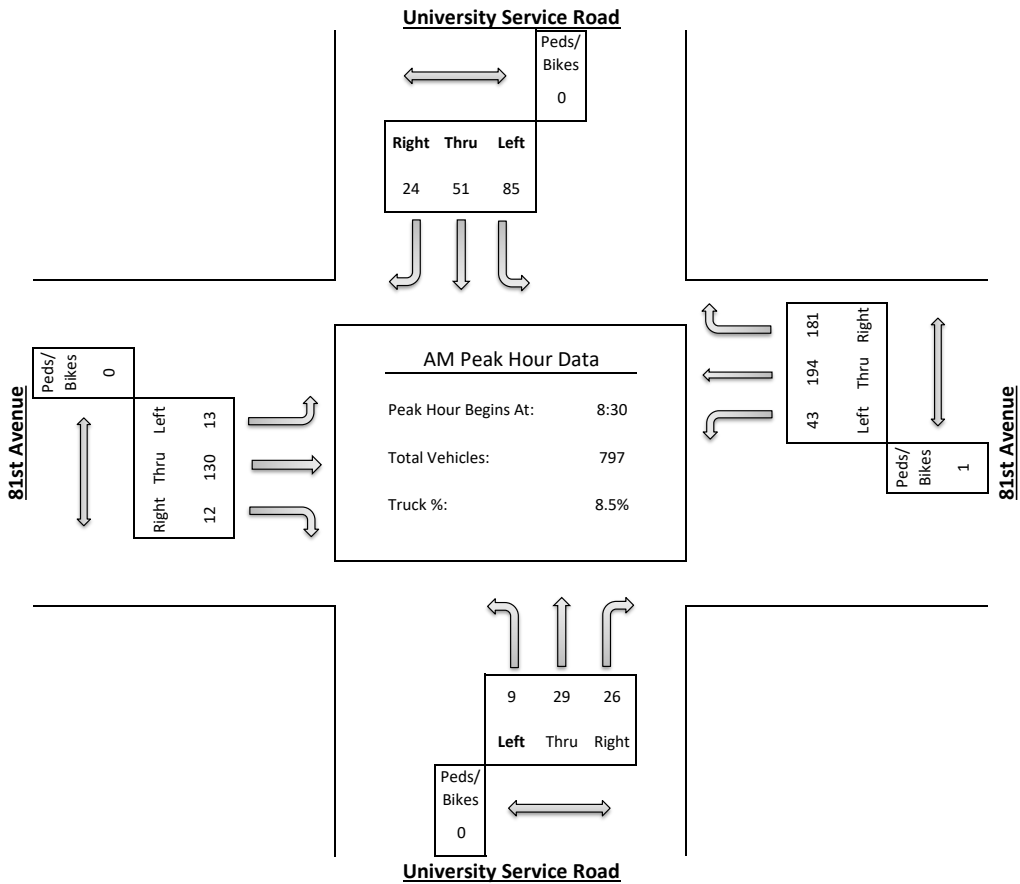

ALLIANT ENGINEERING, INC.

733 S Marquette Ave #700, Minneapolis, MN 55402

Intersection: 81st Avenue & University Service Road
 Date: 3/21/2024
 Duration: 0600-1800

Site Code: 6141
 Ref Pt: N/A
 Page No: 3 of 4

All Vehicles (Cars & Trucks) Printed

Start Time	University Service Road Southbound						81st Avenue Westbound						University Service Road Northbound						81st Avenue Eastbound						Int. Veh. Total	Int. Ped/Bike Total
	U-Turn	Left	Thru	Right	App. Total	Peds/Bikes	U-Turn	Left	Thru	Right	App. Total	Peds/Bikes	U-Turn	Left	Thru	Right	App. Total	Peds/Bikes	U-Turn	Left	Thru	Right	App. Total	Peds/Bikes		
11:45	--	36	11	17	64	--	--	17	63	46	126	--	--	3	8	15	26	--	--	16	64	5	85	--	301	--
12:00	--	33	13	13	59	--	--	12	46	58	116	--	--	8	6	14	28	--	--	7	66	7	80	--	283	--
12:15	--	40	7	9	56	--	--	10	57	58	125	--	--	2	9	21	32	--	--	9	53	6	68	--	281	--
12:30	--	41	13	12	66	1	--	17	63	63	143	--	--	2	5	15	22	--	--	15	65	2	82	--	313	1
Hour Total	--	150	44	51	245	1	--	56	229	225	510	--	--	15	28	65	108	--	--	47	248	20	315	--	1178	1
% of App.	0.0%	61.2%	18.0%	20.8%			0.0%	11.0%	44.9%	44.1%			0.0%	13.9%	25.9%	60.2%			0.0%	14.9%	78.7%	6.3%				
% of Total	0.0%	12.7%	3.7%	4.3%	20.8%	#####	0.0%	4.8%	19.4%	19.1%	43.3%	0.0%	0.0%	1.3%	2.4%	5.5%	9.2%	0.0%	0.0%	4.0%	21.1%	1.7%	26.7%	0.0%		
Cars Total	--	148	44	51	243	1	--	56	217	220	493	--	--	15	28	64	107	--	--	47	230	19	296	--	1139	1
Cars % of Movement	0.0%	98.7%	100%	100%	99.2%	#####	0.0%	100%	94.8%	97.8%	96.7%	0.0%	0.0%	100%	100%	98.5%	99.1%	0.0%	0.0%	100%	92.7%	95.0%	94.0%	0.0%	96.7%	
Trucks Total	--	2	--	--	2	--	--	--	12	5	17	--	--	--	--	1	1	--	--	--	18	1	19	--	39	--
Trucks % of Movement	0.0%	1.3%	0.0%	0.0%	0.8%	--	0.0%	0.0%	5.2%	2.2%	3.3%	--	0.0%	0.0%	0.0%	1.5%	0.9%	--	0.0%	0.0%	7.3%	5.0%	6.0%	--	3.3%	

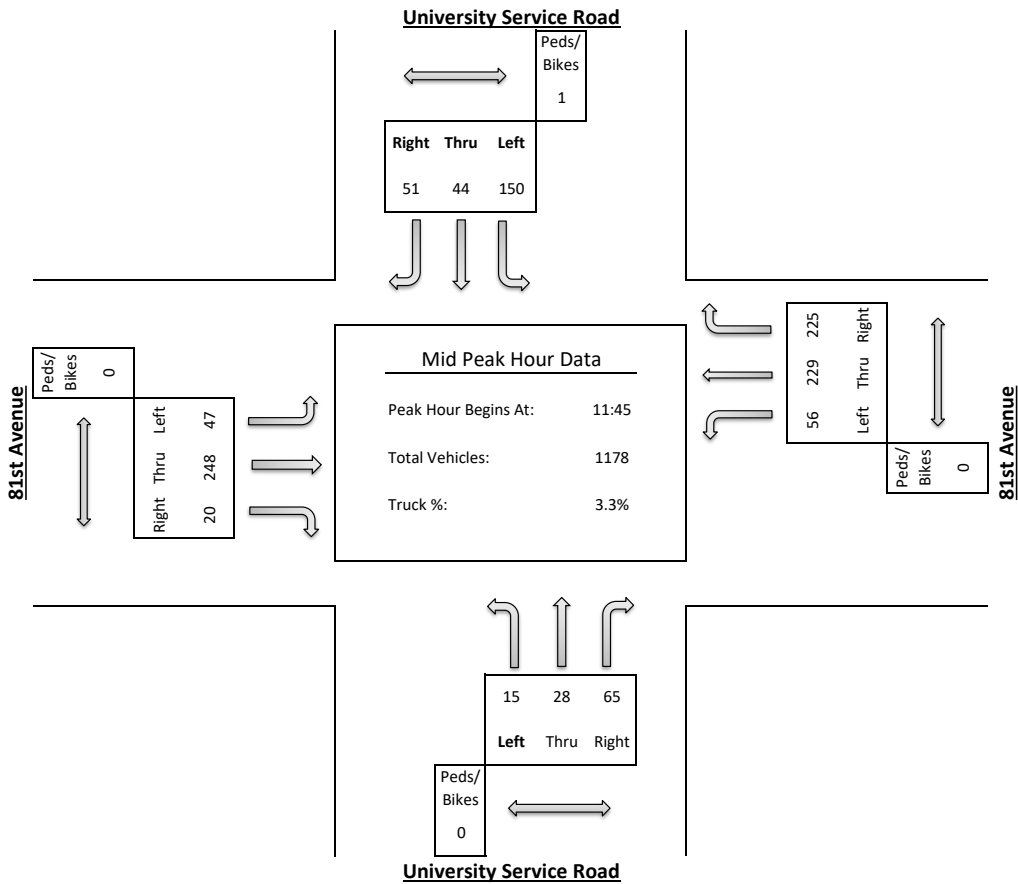

ALLIANT ENGINEERING, INC.

733 S Marquette Ave #700, Minneapolis, MN 55402

Intersection: 81st Avenue & University Service Road
 Date: 3/21/2024
 Duration: 0600-1800

Site Code: 6141
 Ref Pt: N/A
 Page No: 4 of 4

All Vehicles (Cars & Trucks) Printed

Start Time	University Service Road Southbound						81st Avenue Westbound						University Service Road Northbound						81st Avenue Eastbound						Int. Veh. Total	Int. Ped/Bike Total
	U-Turn	Left	Thru	Right	App. Total	Peds/Bikes	U-Turn	Left	Thru	Right	App. Total	Peds/Bikes	U-Turn	Left	Thru	Right	App. Total	Peds/Bikes	U-Turn	Left	Thru	Right	App. Total	Peds/Bikes		
16:30	--	39	12	6	57	--	--	4	65	50	119	--	--	3	6	5	14	1	--	8	95	3	106	--	296	1
16:45	--	48	8	4	60	--	--	8	74	50	132	--	--	6	12	10	28	--	--	10	77	4	91	--	311	--
17:00	--	48	8	19	75	--	--	9	74	40	123	1	--	7	5	10	22	--	--	13	118	7	138	--	358	1
17:15	1	48	6	7	62	--	--	3	49	53	105	--	--	4	9	7	20	--	--	17	95	8	120	--	307	--
Hour Total	1	183	34	36	254	--	--	24	262	193	479	1	--	20	32	32	84	1	--	48	385	22	455	--	1272	2
% of App.	0.4%	72.0%	13.4%	14.2%			0.0%	5.0%	54.7%	40.3%			0.0%	23.8%	38.1%	38.1%			0.0%	10.5%	84.6%	4.8%				
% of Total	0.1%	14.4%	2.7%	2.8%	20.0%	0.0%	0.0%	1.9%	20.6%	15.2%	37.7%	50.0%	0.0%	1.6%	2.5%	2.5%	6.6%	50.0%	0.0%	3.8%	30.3%	1.7%	35.8%	0.0%		
Cars Total	1	182	34	35	252	--	--	23	226	192	441	1	--	20	32	31	83	1	--	48	376	22	446	--	1222	2
Cars % of Movement	100%	99.5%	100%	97.2%	99.2%	0.0%	0.0%	95.8%	86.3%	99.5%	92.1%	50.0%	0.0%	100%	100%	96.9%	98.8%	50.0%	0.0%	100%	97.7%	100%	98.0%	0.0%	96.1%	
Trucks Total	--	1	--	1	2	--	--	1	36	1	38	--	--	--	--	1	1	--	--	--	9	--	9	--	50	--
Trucks % of Movement	0.0%	0.5%	0.0%	2.8%	0.8%	--	0.0%	4.2%	13.7%	0.5%	7.9%	--	0.0%	0.0%	0.0%	3.1%	1.2%	--	0.0%	0.0%	2.3%	0.0%	2.0%	--	3.9%	

