



MINNESOTA DEPT OF TRANSPORTATION

TRAFFIC DATA COLLECTION - METRO

TH-47 at McKinley St NW
 Ref.Pt.: 021.585
 JAMAR # 631 RE
 TURN MOVEMENT COUNT

ANOKA

File Name : TH-47 at McKinley St NW 2008
 Site Code : 00000000
 Start Date : 4/17/2008
 Page No : 1

Groups Printed- Cars & Trucks

Start Time	TH-47 Southbound				McKinley St NW Westbound				TH-47 Northbound				McKinley St NW Eastbound				Int. Total
	Left	Thru	Right	Peds	Left	Thru	Right	Peds	Left	Thru	Right	Peds	Left	Thru	Right	Peds	
05:45	1	195	2	0	2	0	0	0	5	15	0	0	0	0	11	0	231
Total	1	195	2	0	2	0	0	0	5	15	0	0	0	0	11	0	231
06:00	0	210	1	0	1	1	0	0	4	11	1	0	0	0	15	0	244
06:15	0	228	0	0	3	0	0	0	5	25	0	0	0	0	13	0	274
06:30	0	238	2	0	2	0	1	0	5	46	1	0	0	0	19	0	314
06:45	1	255	1	0	7	1	2	0	8	28	1	0	0	0	22	0	326
Total	1	931	4	0	13	2	3	0	22	110	3	0	0	0	69	0	1158
07:00	1	240	1	0	4	1	1	0	7	46	1	0	0	0	20	0	322
07:15	1	223	1	0	1	1	3	0	6	41	2	0	1	0	13	0	293
07:30	0	204	1	0	2	0	2	0	9	85	2	0	0	0	19	0	324
07:45	0	267	1	0	5	1	0	0	13	77	1	0	0	0	11	0	376
Total	2	934	4	0	12	3	6	0	35	249	6	0	1	0	63	0	1315
08:00	0	207	0	0	4	1	1	0	6	59	1	0	0	0	10	0	289
08:15	0	173	4	0	3	0	0	0	3	55	0	0	0	0	10	0	248
08:30	0	177	2	0	2	0	1	0	12	66	1	0	0	0	13	0	274
08:45	0	200	1	0	3	0	1	0	7	64	1	0	1	0	12	0	290
Total	0	757	7	0	12	1	3	0	28	244	3	0	1	0	45	0	1101
*** BREAK ***																	
14:30	1	109	2	0	2	0	0	0	15	152	4	0	0	2	27	0	314
14:45	3	100	5	0	1	0	1	0	19	199	3	0	4	0	16	0	351
Total	4	209	7	0	3	0	1	0	34	351	7	0	4	2	43	0	665
15:00	0	118	3	0	2	1	0	0	29	197	1	0	4	1	49	0	405
15:15	1	115	1	0	1	0	0	0	37	247	5	0	1	0	20	0	428
15:30	2	149	1	0	1	1	1	0	34	214	6	0	1	1	28	0	439
15:45	3	134	6	0	2	1	3	0	23	225	3	0	0	0	23	0	423
Total	6	516	11	0	6	3	4	0	123	883	15	0	6	2	120	0	1695
16:00	0	130	3	0	2	0	0	0	47	273	6	0	1	0	23	0	485
16:15	0	134	3	0	1	0	2	0	41	227	5	0	0	1	16	0	430
16:30	0	137	2	0	1	0	3	0	31	217	5	0	1	0	23	0	420
16:45	0	162	3	0	0	0	0	0	64	230	5	0	0	0	19	0	483
Total	0	563	11	0	4	0	5	0	183	947	21	0	2	1	81	0	1818
17:00	1	142	3	0	2	0	0	0	60	224	8	0	0	0	37	0	477
17:15	1	126	1	0	0	0	0	0	55	267	5	0	0	0	23	0	478
17:30	1	121	5	0	1	1	0	0	29	230	9	0	2	0	16	0	415
17:45	4	129	7	0	1	2	3	0	40	259	9	0	2	0	23	0	479
Total	7	518	16	0	4	3	3	0	184	980	31	0	4	0	99	0	1849
Grand Total	21	4623	62	0	56	12	25	0	614	3779	86	0	18	5	531	0	9832
Apprch %	0.4	98.2	1.3	0	60.2	12.9	26.9	0	13.7	84.4	1.9	0	3.2	0.9	95.8	0	
Total %	0.2	47	0.6	0	0.6	0.1	0.3	0	6.2	38.4	0.9	0	0.2	0.1	5.4	0	

PM - NB Traffic : occasional back-up queue at McKinley St NW from the stoplight at Bunker Lake Blvd.



MINNESOTA DEPT OF TRANSPORTATION

TRAFFIC DATA COLLECTION - METRO

TH-47 at McKinley St NW ANOKA
 Ref.Pt.: 021.585
 JAMAR # 631 RE
 TURN MOVEMENT COUNT

File Name : TH-47 at McKinley St NW 2008
 Site Code : 00000000
 Start Date : 4/17/2008
 Page No : 2

Start Time	TH-47 Southbound					McKinley St NW Westbound					TH-47 Northbound					McKinley St NW Eastbound					Int. Total
	Left	Thru	Right	Peds	App. Total	Left	Thru	Right	Peds	App. Total	Left	Thru	Right	Peds	App. Total	Left	Thru	Right	Peds	App. Total	
Peak Hour Analysis From 05:45 to 08:45 - Peak 1 of 1																					
Peak Hour for Entire Intersection Begins at 07:00																					
07:00	1	240	1	0	242	4	1	1	0	6	7	46	1	0	54	0	0	20	0	20	322
07:15	1	223	1	0	225	1	1	3	0	5	6	41	2	0	49	1	0	13	0	14	293
07:30	0	204	1	0	205	2	0	2	0	4	9	85	2	0	96	0	0	19	0	19	324
07:45	0	267	1	0	268	5	1	0	0	6	13	77	1	0	91	0	0	11	0	11	376
Total Volume	2	934	4	0	940	12	3	6	0	21	35	249	6	0	290	1	0	63	0	64	1315
% App. Total																					
PHF	.500	.875	1.000	.000	.877	.600	.750	.500	.000	.875	.673	.732	.750	.000	.755	.250	.000	.788	.000	.800	.874

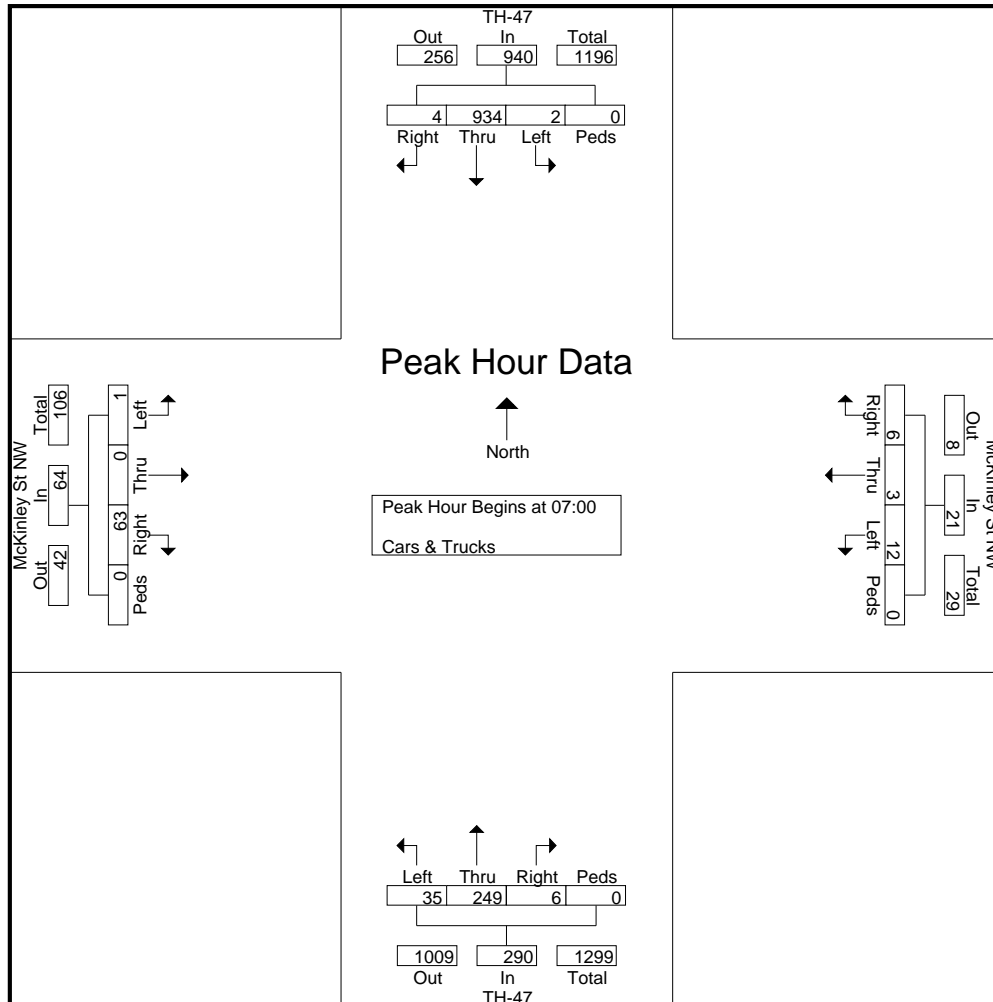



MINNESOTA DEPT OF TRANSPORTATION

TRAFFIC DATA COLLECTION - METRO

TH-47 at McKinley St NW
 Ref.Pt.: 021.585
 JAMAR # 631 RE
 TURN MOVEMENT COUNT

ANOKA

File Name : TH-47 at McKinley St NW 2008
 Site Code : 00000000
 Start Date : 4/17/2008
 Page No : 3

Start Time	TH-47 Southbound					McKinley St NW Westbound					TH-47 Northbound					McKinley St NW Eastbound					Int. Total
	Left	Thru	Right	Peds	App. Total	Left	Thru	Right	Peds	App. Total	Left	Thru	Right	Peds	App. Total	Left	Thru	Right	Peds	App. Total	
Peak Hour Analysis From 14:30 to 17:45 - Peak 1 of 1																					
Peak Hour for Entire Intersection Begins at 16:30																					
16:30	0	137	2	0	139	1	0	3	0	4	31	217	5	0	253	1	0	23	0	24	420
16:45	0	162	3	0	165	0	0	0	0	0	64	230	5	0	299	0	0	19	0	19	483
17:00	1	142	3	0	146	2	0	0	0	2	60	224	8	0	292	0	0	37	0	37	477
17:15	1	126	1	0	128	0	0	0	0	0	55	267	5	0	327	0	0	23	0	23	478
Total Volume	2	567	9	0	578	3	0	3	0	6	210	938	23	0	1171	1	0	102	0	103	1858
% App. Total																					
PHF	.500	.875	.750	.000	.876	.375	.000	.250	.000	.375	.820	.878	.719	.000	.895	.250	.000	.689	.000	.696	.962

