

TRAFFIC DATA INC.

3268 Xenwood Ave S
St Louis Park, MN 55416

TH-5 at Oak Ave WACONIA
Ref.Pt.: 030+01.006
TDI Inc
TURN MOVEMENT COUNT

File Name : 2681111 Hwy 5 & Oak
Site Code : 2681111
Start Date : 2/16/2011
Page No : 1

Groups Printed- Class 1

Start Time	Oak Ave Southbound				TH-5 Westbound				Oak Ave Northbound				TH-5 Eastbound				Int. Total
	Left	Thru	Right	Peds	Left	Thru	Right	Peds	Left	Thru	Right	Peds	Left	Thru	Right	Peds	
06:00	11	4	4	0	2	8	6	0	1	3	18	0	3	43	0	0	103
06:15	12	8	1	0	1	13	2	0	2	2	15	0	1	54	0	0	111
06:30	18	4	4	0	4	17	5	0	1	7	29	0	7	84	0	0	180
06:45	15	5	7	0	4	18	14	0	2	8	30	0	7	77	0	0	187
Total	56	21	16	0	11	56	27	0	6	20	92	0	18	258	0	0	581
07:00	16	4	6	0	5	16	27	0	2	14	33	0	9	58	0	1	191
07:15	34	3	5	0	3	19	62	0	3	41	39	0	17	70	2	0	298
07:30	60	23	10	0	9	19	80	0	3	64	50	0	22	78	3	3	424
07:45	75	25	5	0	14	23	50	0	3	37	36	0	13	86	3	0	370
Total	185	55	26	0	31	77	219	0	11	156	158	0	61	292	8	4	1283
08:00	26	8	1	0	13	27	9	0	2	13	23	0	5	80	0	1	208
08:15	13	3	3	0	7	26	5	0	1	7	20	0	2	64	1	0	152
08:30	11	5	3	0	9	18	13	0	1	9	14	0	1	49	2	0	135
08:45	6	9	0	0	4	16	18	0	1	5	19	0	3	42	1	0	124
Total	56	25	7	0	33	87	45	0	5	34	76	0	11	235	4	1	619
09:00	16	3	2	0	8	29	16	0	3	8	16	0	4	39	2	0	146
09:15	17	3	3	0	9	24	11	0	0	5	15	0	0	43	0	0	130
09:30	13	3	2	0	6	20	7	0	1	5	17	0	2	25	4	0	105
09:45	7	2	0	0	9	20	6	0	0	6	8	0	4	35	0	0	97
Total	53	11	7	0	32	93	40	0	4	24	56	0	10	142	6	0	478
10:00	11	6	2	0	6	27	10	0	1	6	12	0	1	38	2	0	122
10:15	14	2	1	0	5	34	10	0	0	4	11	0	0	28	0	0	109
10:30	14	6	3	0	7	33	8	0	0	3	13	0	4	31	2	0	124
10:45	12	7	1	0	11	35	9	0	2	3	15	0	3	37	2	0	137
Total	51	21	7	0	29	129	37	0	3	16	51	0	8	134	6	0	492
11:00	6	3	1	0	20	44	14	0	1	6	20	0	1	27	1	0	144
11:15	10	9	1	0	14	40	12	0	0	2	18	0	2	28	2	0	138
11:30	11	5	1	0	16	33	9	0	4	6	14	0	3	44	1	1	148
11:45	8	7	2	0	13	33	9	0	0	8	17	0	4	43	0	0	144
Total	35	24	5	0	63	150	44	0	5	22	69	0	10	142	4	1	574
12:00	15	10	6	0	12	33	18	0	2	9	10	0	2	29	1	0	147
12:15	13	7	4	0	11	27	11	0	0	5	17	0	1	29	2	1	128
12:30	14	5	2	0	22	48	9	0	1	4	13	0	2	39	0	4	163
12:45	10	9	2	0	18	37	13	0	0	5	12	0	1	32	1	0	140
Total	52	31	14	0	63	145	51	0	3	23	52	0	6	129	4	5	578
13:00	14	4	5	0	11	36	14	0	2	7	17	0	1	29	2	1	143
13:15	10	5	4	0	9	35	17	0	1	8	16	0	1	33	2	1	142
13:30	9	4	4	0	10	44	13	1	2	7	10	0	1	40	2	0	147
13:45	10	5	4	0	11	36	6	0	0	6	16	0	4	35	1	1	135
Total	43	18	17	0	41	151	50	1	5	28	59	0	7	137	7	3	567
14:00	10	4	3	0	12	45	16	0	0	6	9	0	3	27	3	0	138
14:15	16	9	4	0	13	51	12	0	0	7	18	0	1	36	2	2	171
14:30	19	11	5	0	17	48	35	0	0	6	15	0	2	32	2	2	194
14:45	49	45	3	4	27	41	41	3	0	16	13	2	3	29	1	9	286
Total	94	69	15	4	69	185	104	3	0	35	55	2	9	124	8	13	789
15:00	91	55	13	0	18	77	31	1	3	27	19	2	5	29	1	7	379
15:15	42	18	9	0	13	57	15	0	4	12	14	0	2	33	1	3	223
15:30	28	9	9	0	30	120	24	0	3	14	14	0	5	36	3	0	295

TRAFFIC DATA INC.

3268 Xenwood Ave S
St Louis Park, MN 55416

TH-5 at Oak Ave WACONIA
Ref.Pt.: 030+01.006
TDI Inc
TURN MOVEMENT COUNT

File Name : 2681111 Hwy 5 & Oak
Site Code : 2681111
Start Date : 2/16/2011
Page No : 2

Groups Printed- Class 1

Start Time	Oak Ave Southbound				TH-5 Westbound				Oak Ave Northbound				TH-5 Eastbound				Int. Total
	Left	Thru	Rght	Peds	Left	Thru	Rght	Peds	Left	Thru	Rght	Peds	Left	Thru	Rght	Peds	
15:45	21	16	6	0	17	90	24	0	2	14	23	0	5	51	2	2	273
Total	182	98	37	0	78	344	94	1	12	67	70	2	17	149	7	12	1170
16:00	21	19	10	0	32	79	36	1	2	13	14	0	4	31	5	1	268
16:15	25	22	7	0	29	79	28	0	3	16	17	0	6	33	3	1	269
16:30	25	18	10	0	26	120	31	0	3	21	22	0	8	38	6	4	332
16:45	21	13	7	0	32	89	33	0	4	21	25	0	8	32	0	1	286
Total	92	72	34	0	119	367	128	1	12	71	78	0	26	134	14	7	1155
17:00	34	21	11	0	33	89	42	0	6	17	17	0	15	38	6	0	329
17:15	21	23	13	0	38	76	28	0	6	18	18	0	4	43	4	2	294
17:30	29	25	5	0	35	66	28	0	1	14	17	0	5	29	3	2	259
17:45	22	22	8	0	26	60	32	0	3	20	20	0	11	29	5	4	262
Total	106	91	37	0	132	291	130	0	16	69	72	0	35	139	18	8	1144
18:00	31	28	14	0	28	62	35	0	1	20	25	0	3	35	4	0	286
18:15	20	19	7	0	32	43	38	0	1	18	36	0	2	32	3	0	251
18:30	29	17	13	0	28	41	24	0	2	11	12	0	3	27	1	0	208
18:45	14	16	5	0	53	40	27	0	0	13	13	0	1	17	1	0	200
Total	94	80	39	0	141	186	124	0	4	62	86	0	9	111	9	0	945
Grand Total	1099	616	261	4	842	2261	1093	6	86	627	974	4	227	2126	95	54	10375
Apprch %	55.5	31.1	13.2	0.2	20	53.8	26	0.1	5.1	37.1	57.6	0.2	9.1	85	3.8	2.2	
Total %	10.6	5.9	2.5	0	8.1	21.8	10.5	0.1	0.8	6	9.4	0	2.2	20.5	0.9	0.5	

TRAFFIC DATA INC.

3268 Xenwood Ave S
St Louis Park, MN 55416

TH-5 at Oak Ave WACONIA
Ref.Pt.: 030+01.006
TDI Inc
TURN MOVEMENT COUNT

File Name : 2681111 Hwy 5 & Oak
Site Code : 2681111
Start Date : 2/16/2011
Page No : 3

Start Time	Oak Ave Southbound					TH-5 Westbound					Oak Ave Northbound					TH-5 Eastbound					Int. Total
	Left	Thru	Rght	Peds	App. Total	Left	Thru	Rght	Peds	App. Total	Left	Thru	Rght	Peds	App. Total	Left	Thru	Rght	Peds	App. Total	
Peak Hour Analysis From 06:00 to 10:00 - Peak 1 of 1																					
Peak Hour for Entire Intersection Begins at 07:15																					
07:15	34	3	5	0	42	3	19	62	0	84	3	41	39	0	83	17	70	2	0	89	298
07:30	60	23	10	0	93	9	19	80	0	108	3	64	50	0	117	22	78	3	3	106	424
07:45	75	25	5	0	105	14	23	50	0	87	3	37	36	0	76	13	86	3	0	102	370
08:00	26	8	1	0	35	13	27	9	0	49	2	13	23	0	38	5	80	0	1	86	208
Total Volume	195	59	21	0	275	39	88	201	0	328	11	155	148	0	314	57	314	8	4	383	1300
% App. Total	70.9	21.5	7.6	0		11.9	26.8	61.3	0		3.5	49.4	47.1	0		14.9	82	2.1	1		
PHF	.650	.590	.525	.000	.655	.696	.815	.628	.000	.759	.917	.605	.740	.000	.671	.648	.913	.667	.333	.903	.767

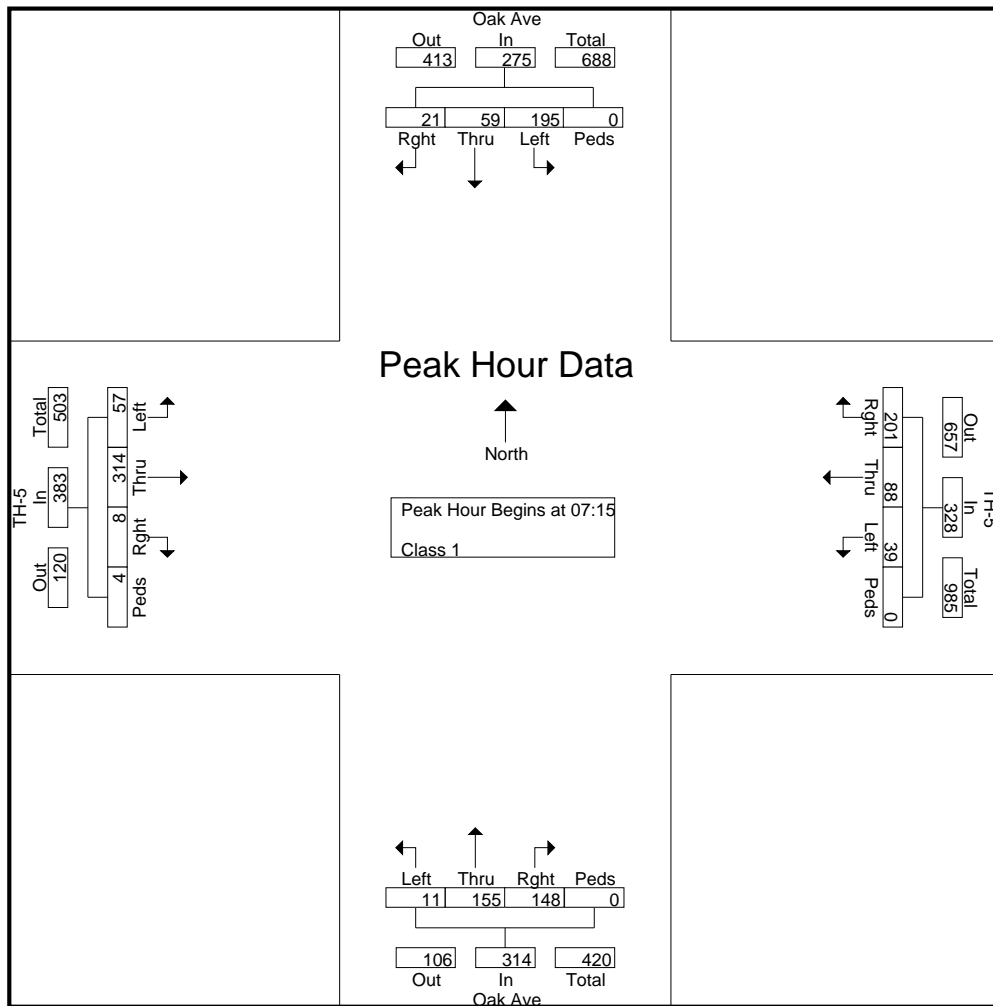

TRAFFIC DATA INC.

3268 Xenwood Ave S
St Louis Park, MN 55416

TH-5 at Oak Ave WACONIA
Ref.Pt.: 030+01.006
TDI Inc
TURN MOVEMENT COUNT

File Name : 2681111 Hwy 5 & Oak
Site Code : 2681111
Start Date : 2/16/2011
Page No : 4

Start Time	Oak Ave Southbound					TH-5 Westbound					Oak Ave Northbound					TH-5 Eastbound					Int. Total
	Left	Thru	Rght	Peds	App. Total	Left	Thru	Rght	Peds	App. Total	Left	Thru	Rght	Peds	App. Total	Left	Thru	Rght	Peds	App. Total	
Peak Hour Analysis From 15:00 to 18:45 - Peak 1 of 1																					
Peak Hour for Entire Intersection Begins at 16:30																					
16:30	25	18	10	0	53	26	120	31	0	177	3	21	22	0	46	8	38	6	4	56	332
16:45	21	13	7	0	41	32	89	33	0	154	4	21	25	0	50	8	32	0	1	41	286
17:00	34	21	11	0	66	33	89	42	0	164	6	17	17	0	40	15	38	6	0	59	329
17:15	21	23	13	0	57	38	76	28	0	142	6	18	18	0	42	4	43	4	2	53	294
Total Volume	101	75	41	0	217	129	374	134	0	637	19	77	82	0	178	35	151	16	7	209	1241
% App. Total	46.5	34.6	18.9	0		20.3	58.7	21	0		10.7	43.3	46.1	0		16.7	72.2	7.7	3.3		
PHF	.743	.815	.788	.000	.822	.849	.779	.798	.000	.900	.792	.917	.820	.000	.890	.583	.878	.667	.438	.886	.934

