



MINNESOTA DEPT OF TRANSPORTATION

TRAFFIC DATA COLLECTION - METRO

TH-5 at TH-41 Chanhassen
 Ref.Pt.: 042.422
 Data by: Westwood Professional Services
 TURN MOVEMENT COUNT

File Name : TH-5 at TH-41 2008
 Site Code : 03053424
 Start Date : 9/24/2008
 Page No : 1

Groups Printed- Unshifted

Start Time	TH-41 Southbound				TH-5 Westbound				TH-41 Northbound				TH-5 Eastbound				Int. Total
	Left	Thru	Right	Peds	Left	Thru	Right	Peds	Left	Thru	Right	Peds	Left	Thru	Right	Peds	
06:00	12	23	7	0	43	19	0	0	4	25	8	1	21	134	37	0	334
06:15	18	44	7	0	35	49	4	0	5	34	13	0	29	169	44	0	451
06:30	21	42	23	0	18	51	13	0	19	42	26	0	45	200	45	0	545
06:45	34	51	19	0	28	92	8	0	27	46	18	0	50	241	38	0	652
Total	85	160	56	0	124	211	25	0	55	147	65	1	145	744	164	0	1982
07:00	31	58	41	0	15	104	6	0	9	48	18	0	47	243	29	0	649
07:15	30	68	13	0	29	60	13	0	13	75	28	0	47	245	34	0	655
07:30	53	80	16	0	39	58	13	0	10	56	38	0	48	299	48	0	758
07:45	47	98	16	0	37	73	7	0	11	62	28	0	50	311	45	0	785
Total	161	304	86	0	120	295	39	0	43	241	112	0	192	1098	156	0	2847
08:00	59	74	24	0	29	51	4	0	18	59	32	0	38	220	40	0	648
08:15	43	57	16	0	34	71	16	0	15	74	20	0	30	216	34	0	626
08:30	43	68	22	0	38	58	7	0	12	39	28	0	42	210	35	0	602
08:45	50	54	22	0	24	58	20	0	14	51	22	0	28	194	32	0	569
Total	195	253	84	0	125	238	47	0	59	223	102	0	138	840	141	0	2445
*** BREAK ***																	
11:00	17	24	6	0	39	103	32	0	21	55	28	0	28	114	16	0	483
11:15	18	38	24	1	35	87	38	0	15	56	42	0	33	116	21	0	524
11:30	30	57	43	0	32	118	24	0	24	69	36	0	28	110	16	0	587
11:45	67	59	38	0	46	105	31	0	22	40	30	0	24	95	25	0	582
Total	132	178	111	1	152	413	125	0	82	220	136	0	113	435	78	0	2176
12:00	30	39	19	0	38	97	29	0	29	47	30	0	32	98	17	0	505
12:15	26	44	17	0	37	99	36	0	20	52	42	0	41	118	25	0	557
12:30	32	44	30	0	46	119	41	1	24	52	30	0	38	124	26	0	607
12:45	35	60	18	0	33	110	32	0	24	35	47	0	22	108	25	0	549
Total	123	187	84	0	154	425	138	1	97	186	149	0	133	448	93	0	2218
*** BREAK ***																	
15:00	16	72	44	0	49	168	36	0	67	72	33	0	30	111	17	0	715
15:15	30	62	26	0	33	176	35	1	44	61	41	0	29	110	23	0	671
15:30	29	46	21	0	34	188	30	1	58	76	38	0	30	120	8	0	679
15:45	24	51	20	0	25	170	42	0	44	81	37	0	26	134	13	0	667
Total	99	231	111	0	141	702	143	2	213	290	149	0	115	475	61	0	2732
16:00	36	62	32	0	40	191	39	0	38	80	32	0	32	93	15	0	690
16:15	19	60	29	0	28	240	56	0	54	81	30	0	25	145	15	0	782
16:30	29	51	31	0	21	218	64	0	73	111	46	0	44	127	21	0	836
16:45	25	67	29	0	31	205	69	0	57	76	58	0	28	126	7	0	778
Total	109	240	121	0	120	854	228	0	222	348	166	0	129	491	58	0	3086
17:00	18	43	32	0	26	260	67	0	55	96	33	0	39	140	7	0	816
17:15	27	63	24	0	36	226	54	0	41	102	34	0	25	140	7	0	779
17:30	26	44	26	0	36	220	44	1	46	91	31	0	37	125	14	0	741
17:45	25	62	24	0	31	199	39	0	27	64	29	0	20	145	17	0	682
Total	96	212	106	0	129	905	204	1	169	353	127	0	121	550	45	0	3018
Grand Total	1000	1765	759	1	1065	4043	949	4	940	2008	1006	1	1086	5081	796	0	20504
Apprch %	28.4	50.1	21.5	0	17.6	66.7	15.7	0.1	23.8	50.8	25.4	0	15.6	73	11.4	0	
Total %	4.9	8.6	3.7	0	5.2	19.7	4.6	0	4.6	9.8	4.9	0	5.3	24.8	3.9	0	



MINNESOTA DEPT OF TRANSPORTATION

TRAFFIC DATA COLLECTION - METRO

TH-5 at TH-41 Chanhassen
 Ref.Pt.: 042.422
 Data by: Westwood Professional Services
 TURN MOVEMENT COUNT

File Name : TH-5 at TH-41 2008
 Site Code : 03053424
 Start Date : 9/24/2008
 Page No : 2

Start Time	TH-41 Southbound					TH-5 Westbound					TH-41 Northbound					TH-5 Eastbound					Int. Total
	Left	Thru	Right	Peds	App. Total	Left	Thru	Right	Peds	App. Total	Left	Thru	Right	Peds	App. Total	Left	Thru	Right	Peds	App. Total	
Peak Hour Analysis From 06:00 to 08:45 - Peak 1 of 1																					
Peak Hour for Entire Intersection Begins at 07:00																					
07:00	31	58	41	0	130	15	104	6	0	125	9	48	18	0	75	47	243	29	0	319	649
07:15	30	68	13	0	111	29	60	13	0	102	13	75	28	0	116	47	245	34	0	326	655
07:30	53	80	16	0	149	39	58	13	0	110	10	56	38	0	104	48	299	48	0	395	758
07:45	47	98	16	0	161	37	73	7	0	117	11	62	28	0	101	50	311	45	0	406	785
Total Volume	161	304	86	0	551	120	295	39	0	454	43	241	112	0	396	192	1098	156	0	1446	2847
% App. Total	29.2	55.2	15.6	0		26.4	65	8.6	0		10.9	60.9	28.3	0		13.3	75.9	10.8	0		
PHF	.759	.776	.524	.000	.856	.769	.709	.750	.000	.908	.827	.803	.737	.000	.853	.960	.883	.813	.000	.890	.907

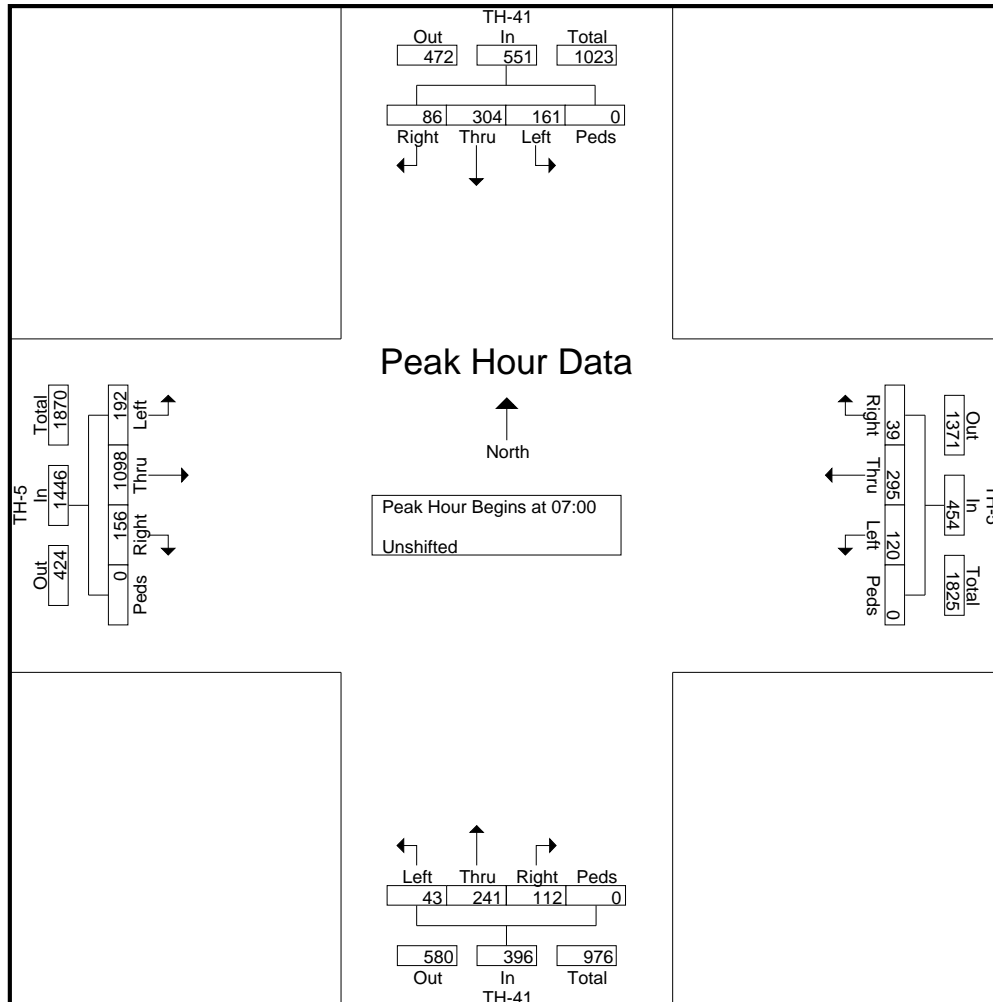



MINNESOTA DEPT OF TRANSPORTATION

TRAFFIC DATA COLLECTION - METRO

TH-5 at TH-41 Chanhassen
 Ref.Pt.: 042.422
 Data by: Westwood Professional Services
 TURN MOVEMENT COUNT

File Name : TH-5 at TH-41 2008
 Site Code : 03053424
 Start Date : 9/24/2008
 Page No : 3

Start Time	TH-41 Southbound					TH-5 Westbound					TH-41 Northbound					TH-5 Eastbound					Int. Total
	Left	Thru	Right	Peds	App. Total	Left	Thru	Right	Peds	App. Total	Left	Thru	Right	Peds	App. Total	Left	Thru	Right	Peds	App. Total	

Peak Hour Analysis From 15:00 to 17:45 - Peak 1 of 1
 Peak Hour for Entire Intersection Begins at 16:15

16:15	19	60	29	0	108	28	240	56	0	324	54	81	30	0	165	25	145	15	0	185	782
16:30	29	51	31	0	111	21	218	64	0	303	73	111	46	0	230	44	127	21	0	192	836
16:45	25	67	29	0	121	31	205	69	0	305	57	76	58	0	191	28	126	7	0	161	778
17:00	18	43	32	0	93	26	260	67	0	353	55	96	33	0	184	39	140	7	0	186	816
Total Volume	91	221	121	0	433	106	923	256	0	1285	239	364	167	0	770	136	538	50	0	724	3212
% App. Total	21	51	27.9	0		8.2	71.8	19.9	0		31	47.3	21.7	0		18.8	74.3	6.9	0		
PHF	.784	.825	.945	.000	.895	.855	.888	.928	.000	.910	.818	.820	.720	.000	.837	.773	.928	.595	.000	.943	.961

