



MINNESOTA DEPT OF TRANSPORTATION

TRAFFIC DATA COLLECTION - METRO

Location: TH-5 AT CSAH-13
 Ref.Pt.: 40+00.403
 JAMAR# 634 DR
 TURN MOVEMENT COUNT

File Name : TH 5 AT CSAH 13 TM 2007
 Site Code : 00000000
 Start Date : 8/8/2007
 Page No : 1

Groups Printed- Unshifted

Start Time	CSAH-13 / ROLLING ACRES RD. Southbound				TH 5 Westbound				CSAH-13 / BAVIARIA RD. Northbound				TH 5 Eastbound				Int. Total
	Left	Thru	Right	Peds	Left	Thru	Right	Peds	Left	Thru	Right	Peds	Left	Thru	Right	Peds	
06:00	87	6	2	0	5	49	17	0	0	6	33	0	8	176	1	0	390
06:15	118	13	4	0	2	69	21	0	5	11	66	0	6	256	3	0	574
06:30	106	11	3	0	8	82	26	0	2	13	87	0	30	253	0	0	621
06:45	103	20	3	0	10	115	17	0	5	29	109	0	13	270	4	0	698
Total	414	50	12	0	25	315	81	0	12	59	295	0	57	955	8	0	2283
07:00	83	7	4	0	23	84	20	0	2	23	108	0	16	262	6	0	638
07:15	88	12	12	0	24	74	14	0	9	37	110	0	18	213	4	0	615
07:30	103	17	11	0	19	102	25	0	1	21	92	0	5	255	0	0	651
07:45	94	13	6	0	41	86	29	0	4	25	115	0	16	224	2	0	655
Total	368	49	33	0	107	346	88	0	16	106	425	0	55	954	12	0	2559
08:00	92	14	9	0	19	87	15	0	0	20	111	0	14	213	5	0	599
08:15	80	14	6	0	15	83	24	0	5	24	73	0	18	197	2	0	541
08:30	80	18	19	0	24	79	20	0	3	17	78	0	18	173	1	0	530
08:45	72	18	12	0	19	87	23	0	4	9	76	0	9	170	6	0	505
Total	324	64	46	0	77	336	82	0	12	70	338	0	59	753	14	0	2175
*** BREAK ***																	
15:00	25	18	20	0	18	192	69	0	6	20	30	0	13	90	6	0	507
15:15	29	14	21	0	29	205	67	0	8	17	26	0	13	97	4	0	530
15:30	33	12	16	0	25	222	96	0	6	11	25	0	8	127	3	0	584
15:45	55	15	28	0	35	218	85	0	11	18	31	0	13	114	6	0	629
Total	142	59	85	0	107	837	317	0	31	66	112	0	47	428	19	0	2250
16:00	35	29	17	0	29	237	90	0	9	18	25	0	6	109	4	0	608
16:15	68	31	33	0	51	205	104	0	10	11	31	0	13	104	6	0	667
16:30	43	15	31	0	44	242	100	0	8	23	28	0	8	96	3	0	641
16:45	47	33	32	0	40	248	90	0	6	14	45	0	8	145	6	0	714
Total	193	108	113	0	164	932	384	0	33	66	129	0	35	454	19	0	2630
17:00	36	35	35	0	47	251	94	0	11	14	45	0	8	117	7	0	700
17:15	46	33	26	0	34	271	114	0	16	22	47	0	13	146	8	0	776
17:30	46	30	27	0	103	220	91	0	7	19	26	0	14	85	11	0	679
17:45	43	71	22	0	124	188	62	0	9	16	55	0	10	121	10	0	731
Total	171	169	110	0	308	930	361	0	43	71	173	0	45	469	36	0	2886
Grand Total	1612	499	399	0	788	3696	1313	0	147	438	1472	0	298	4013	108	0	14783
Apprch %	64.2	19.9	15.9	0	13.6	63.8	22.6	0	7.1	21.3	71.6	0	6.7	90.8	2.4	0	
Total %	10.9	3.4	2.7	0	5.3	25	8.9	0	1	3	10	0	2	27.1	0.7	0	



MINNESOTA DEPT OF TRANSPORTATION

TRAFFIC DATA COLLECTION - METRO

Location: TH-5 AT CSAH-13
 Ref.Pt.: 40+00.403
 JAMAR# 634 DR
 TURN MOVEMENT COUNT

File Name : TH 5 AT CSAH 13 TM 2007
 Site Code : 00000000
 Start Date : 8/8/2007
 Page No : 2

Start Time	CSAH-13 / ROLLING ACRES RD. Southbound					TH 5 Westbound					CSAH-13 / BAVIARIA RD. Northbound					TH 5 Eastbound					Int. Total
	Left	Thru	Right	Peds	App. Total	Left	Thru	Right	Peds	App. Total	Left	Thru	Right	Peds	App. Total	Left	Thru	Right	Peds	App. Total	
Peak Hour Analysis From 06:00 to 08:45 - Peak 1 of 1																					
Peak Hour for Entire Intersection Begins at 06:45																					
06:45	103	20	3	0	126	10	115	17	0	142	5	29	109	0	143	13	270	4	0	287	698
07:00	83	7	4	0	94	23	84	20	0	127	2	23	108	0	133	16	262	6	0	284	638
07:15	88	12	12	0	112	24	74	14	0	112	9	37	110	0	156	18	213	4	0	235	615
07:30	103	17	11	0	131	19	102	25	0	146	1	21	92	0	114	5	255	0	0	260	651
Total Volume	377	56	30	0	463	76	375	76	0	527	17	110	419	0	546	52	1000	14	0	1066	2602
% App. Total	81.4	12.1	6.5	0		14.4	71.2	14.4	0		3.1	20.1	76.7	0		4.9	93.8	1.3	0		
PHF	.915	.700	.625	.000	.884	.792	.815	.760	.000	.902	.472	.743	.952	.000	.875	.722	.926	.583	.000	.929	.932

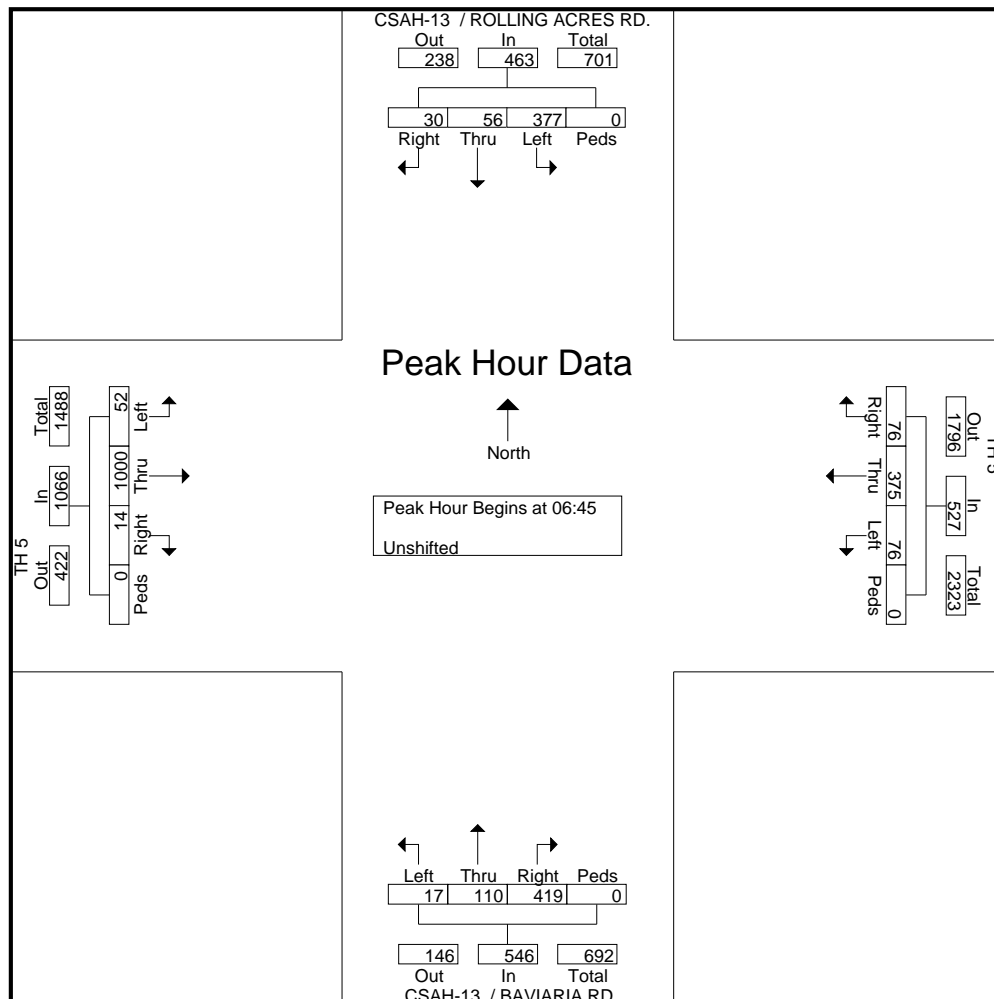



MINNESOTA DEPT OF TRANSPORTATION

TRAFFIC DATA COLLECTION - METRO

Location: TH-5 AT CSAH-13
 Ref.Pt.: 40+00.403
 JAMAR# 634 DR
 TURN MOVEMENT COUNT

File Name : TH 5 AT CSAH 13 TM 2007
 Site Code : 00000000
 Start Date : 8/8/2007
 Page No : 3

Start Time	CSAH-13 / ROLLING ACRES RD. Southbound					TH 5 Westbound					CSAH-13 / BAVARIA RD. Northbound					TH 5 Eastbound					Int. Total
	Left	Thru	Right	Peds	App. Total	Left	Thru	Right	Peds	App. Total	Left	Thru	Right	Peds	App. Total	Left	Thru	Right	Peds	App. Total	
Peak Hour Analysis From 15:00 to 17:45 - Peak 1 of 1																					
Peak Hour for Entire Intersection Begins at 17:00																					
17:00	36	35	35	0	106	47	251	94	0	392	11	14	45	0	70	8	117	7	0	132	700
17:15	46	33	26	0	105	34	271	114	0	419	16	22	47	0	85	13	146	8	0	167	776
17:30	46	30	27	0	103	103	220	91	0	414	7	19	26	0	52	14	85	11	0	110	679
17:45	43	71	22	0	136	124	188	62	0	374	9	16	55	0	80	10	121	10	0	141	731
Total Volume	171	169	110	0	450	308	930	361	0	1599	43	71	173	0	287	45	469	36	0	550	2886
% App. Total	38	37.6	24.4	0		19.3	58.2	22.6	0		15	24.7	60.3	0		8.2	85.3	6.5	0		
PHF	.929	.595	.786	.000	.827	.621	.858	.792	.000	.954	.672	.807	.786	.000	.844	.804	.803	.818	.000	.823	.930

