

Associated Consulting Services (ACS)
 Roseville, MN 55113
 -- TRAFFIC DATA --

MN-51 at Saunders Ave_2022
 City: St Paul
 Data Prepared By: ACS
 TURNING MOVEMENT COUNT

File Name : MN-51 at Saunders Ave_2022
 Site Code :
 Start Date : 5/11/2022
 Page No : 1

Groups Printed- Cars - Trucks

Start Time	MN-51 Southbound				Westbound				MN-51 Northbound				Saunders Ave Eastbound				Int. Total	
	Left	Thru	Right	Peds	Left	Thru	Right	Peds	Left	Thru	Right	Peds	Left	Thru	Right	Peds		
06:00	0	19	1	0	0	0	0	0	0	0	39	0	0	0	0	1	3	63
06:15	0	39	1	0	0	0	0	0	0	1	36	0	0	0	0	0	0	77
06:30	0	41	0	0	0	0	0	0	0	0	55	0	0	2	0	1	1	100
06:45	0	44	2	0	0	0	0	0	0	1	65	0	1	0	0	1	3	117
Total	0	143	4	0	0	0	0	0	0	2	195	0	1	2	0	3	7	357
07:00	0	56	1	0	0	0	0	0	0	2	57	0	0	1	0	4	0	121
07:15	0	95	2	0	0	0	0	0	0	2	82	0	0	4	0	4	3	192
07:30	0	102	2	0	0	0	0	0	0	1	77	0	0	5	0	0	2	189
07:45	0	102	1	0	0	0	0	0	0	3	93	0	0	0	0	3	2	204
Total	0	355	6	0	0	0	0	0	0	8	309	0	0	10	0	11	7	706
08:00	0	110	5	0	0	0	0	0	0	2	116	0	0	2	0	3	7	245
08:15	0	172	0	0	0	0	0	0	0	3	113	0	0	1	0	2	17	308
08:30	0	96	3	0	0	0	0	0	0	5	141	0	0	2	0	5	4	256
08:45	0	95	4	0	0	0	0	0	0	7	91	0	0	1	0	2	9	209
Total	0	473	12	0	0	0	0	0	0	17	461	0	0	6	0	12	37	1018
09:00	0	68	5	0	0	0	0	0	0	6	80	0	0	0	0	4	2	165
09:15	0	68	7	0	0	0	0	0	0	5	87	0	0	20	0	21	2	210
09:30	0	79	3	0	0	0	0	0	0	7	82	0	0	4	0	10	1	186
09:45	0	81	2	0	0	0	0	0	0	1	90	0	0	2	0	1	3	180
Total	0	296	17	0	0	0	0	0	0	19	339	0	0	26	0	36	8	741
10:00	0	73	3	0	0	0	0	0	0	0	88	0	0	2	0	1	2	169
10:15	0	74	2	0	0	0	0	0	0	0	86	0	1	1	0	1	4	169
10:30	0	81	0	0	0	0	0	0	0	2	65	0	0	2	0	3	1	154
10:45	0	84	1	0	0	0	0	0	0	2	83	0	1	2	0	0	2	175
Total	0	312	6	0	0	0	0	0	0	4	322	0	2	7	0	5	9	667
11:00	0	80	1	0	0	0	0	0	0	0	106	0	0	1	0	2	1	191
11:15	0	96	2	0	0	0	0	0	0	1	105	0	0	4	0	0	3	211
11:30	0	96	3	0	0	0	0	0	0	0	81	0	0	2	0	2	11	195
11:45	0	120	1	0	0	0	0	0	0	1	92	0	0	2	0	1	2	219
Total	0	392	7	0	0	0	0	0	0	2	384	0	0	9	0	5	17	816
12:00	0	98	2	0	0	0	0	0	0	1	90	0	0	1	0	2	6	200
12:15	0	99	1	0	0	0	0	0	0	0	96	0	0	0	0	1	5	202
12:30	0	90	4	0	0	0	0	0	0	1	98	0	0	1	0	1	1	196
12:45	0	85	2	0	0	0	0	0	0	2	109	0	0	1	0	2	3	204
Total	0	372	9	0	0	0	0	0	0	4	393	0	0	3	0	6	15	802
13:00	0	76	2	0	0	0	0	0	0	3	97	0	0	1	0	0	1	180
13:15	0	93	2	0	0	0	0	0	0	4	88	0	0	1	0	0	1	189
13:30	0	97	3	0	0	0	0	0	0	3	97	0	0	1	0	0	2	203
13:45	0	99	2	0	0	0	0	0	0	0	104	0	0	0	0	0	2	207
Total	0	365	9	0	0	0	0	0	0	10	386	0	0	3	0	0	6	779
14:00	0	101	2	0	0	0	0	0	0	1	94	0	0	2	0	0	2	202
14:15	0	110	2	0	0	0	0	0	0	1	114	0	0	2	0	0	1	230
14:30	0	107	5	0	0	0	0	0	0	2	129	0	0	1	0	4	1	249
14:45	0	131	1	0	0	0	0	0	0	0	118	0	0	1	0	2	1	254
Total	0	449	10	0	0	0	0	0	0	4	455	0	0	6	0	6	5	935

Associated Consulting Services (ACS)
 Roseville, MN 55113
 -- TRAFFIC DATA --

MN-51 at Saunders Ave_2022
 City: St Paul
 Data Prepared By: ACS
 TURNING MOVEMENT COUNT

File Name : MN-51 at Saunders Ave_2022
 Site Code :
 Start Date : 5/11/2022
 Page No : 2

Groups Printed- Cars - Trucks

Start Time	MN-51 Southbound				Westbound				MN-51 Northbound				Saunders Ave Eastbound				Int. Total
	Left	Thru	Right	Peds	Left	Thru	Right	Peds	Left	Thru	Right	Peds	Left	Thru	Right	Peds	
15:00	0	146	2	0	0	0	0	0	2	156	0	0	2	0	2	22	332
15:15	0	136	1	0	0	0	0	0	1	126	0	4	3	0	4	13	288
15:30	0	138	5	0	0	0	0	0	2	120	0	0	2	0	1	8	276
15:45	0	121	3	0	0	0	0	0	1	137	0	0	3	0	3	4	272
Total	0	541	11	0	0	0	0	0	6	539	0	4	10	0	10	47	1168
16:00	0	145	4	0	0	0	0	0	1	154	0	0	20	0	18	0	342
16:15	0	152	2	0	0	0	0	0	1	138	0	0	10	0	17	9	329
16:30	0	152	1	0	0	0	0	0	1	145	0	2	5	0	4	10	320
16:45	0	153	2	0	0	0	0	0	2	148	0	0	3	0	3	2	313
Total	0	602	9	0	0	0	0	0	5	585	0	2	38	0	42	21	1304
17:00	0	143	4	0	0	0	0	0	2	134	0	0	4	0	1	13	301
17:15	0	129	2	0	0	0	0	0	0	126	0	0	1	0	0	3	261
17:30	0	141	5	0	0	0	0	0	3	120	0	0	4	0	5	3	281
17:45	0	189	2	0	0	0	0	0	0	130	0	0	2	0	7	2	332
Total	0	602	13	0	0	0	0	0	5	510	0	0	11	0	13	21	1175
Grand Total	0	4902	113	0	0	0	0	0	86	4878	0	9	131	0	149	200	10468
Apprch %	0	97.7	2.3	0	0	0	0	0	1.7	98.1	0	0.2	27.3	0	31	41.7	
Total %	0	46.8	1.1	0	0	0	0	0	0.8	46.6	0	0.1	1.3	0	1.4	1.9	
Cars	0	4607	110	0	0	0	0	0	84	4568	0	9	128	0	144	200	9850
% Cars	0	94	97.3	0	0	0	0	0	97.7	93.6	0	100	97.7	0	96.6	100	94.1
Trucks	0	295	3	0	0	0	0	0	2	310	0	0	3	0	5	0	618
% Trucks	0	6	2.7	0	0	0	0	0	2.3	6.4	0	0	2.3	0	3.4	0	5.9

Associated Consulting Services (ACS)
 Roseville, MN 55113
 -- TRAFFIC DATA --

MN-51 at Saunders Ave_2022
 City: St Paul
 Data Prepared By: ACS
 TURNING MOVEMENT COUNT

File Name : MN-51 at Saunders Ave_2022
 Site Code :
 Start Date : 5/11/2022
 Page No : 3

Start Time	MN-51 Southbound					Westbound					MN-51 Northbound					Saunders Ave Eastbound					Int. Total
	Left	Thru	Right	Peds	App. Total	Left	Thru	Right	Peds	App. Total	Left	Thru	Right	Peds	App. Total	Left	Thru	Right	Peds	App. Total	
Peak Hour Analysis From 06:00 to 11:45 - Peak 1 of 1																					
Peak Hour for Entire Intersection Begins at 08:00																					
08:00	0	110	5	0	115	0	0	0	0	0	2	116	0	0	118	2	0	3	7	12	245
08:15	0	172	0	0	172	0	0	0	0	0	3	113	0	0	116	1	0	2	17	20	308
08:30	0	96	3	0	99	0	0	0	0	0	5	141	0	0	146	2	0	5	4	11	256
08:45	0	95	4	0	99	0	0	0	0	0	7	91	0	0	98	1	0	2	9	12	209
Total Volume	0	473	12	0	485	0	0	0	0	0	17	461	0	0	478	6	0	12	37	55	1018
% App. Total	0	97.5	2.5	0		0	0	0	0		3.6	96.4	0	0		10.9	0	21.8	67.3		
PHF	.000	.688	.600	.000	.705	.000	.000	.000	.000	.000	.607	.817	.000	.000	.818	.750	.000	.600	.544	.688	.826

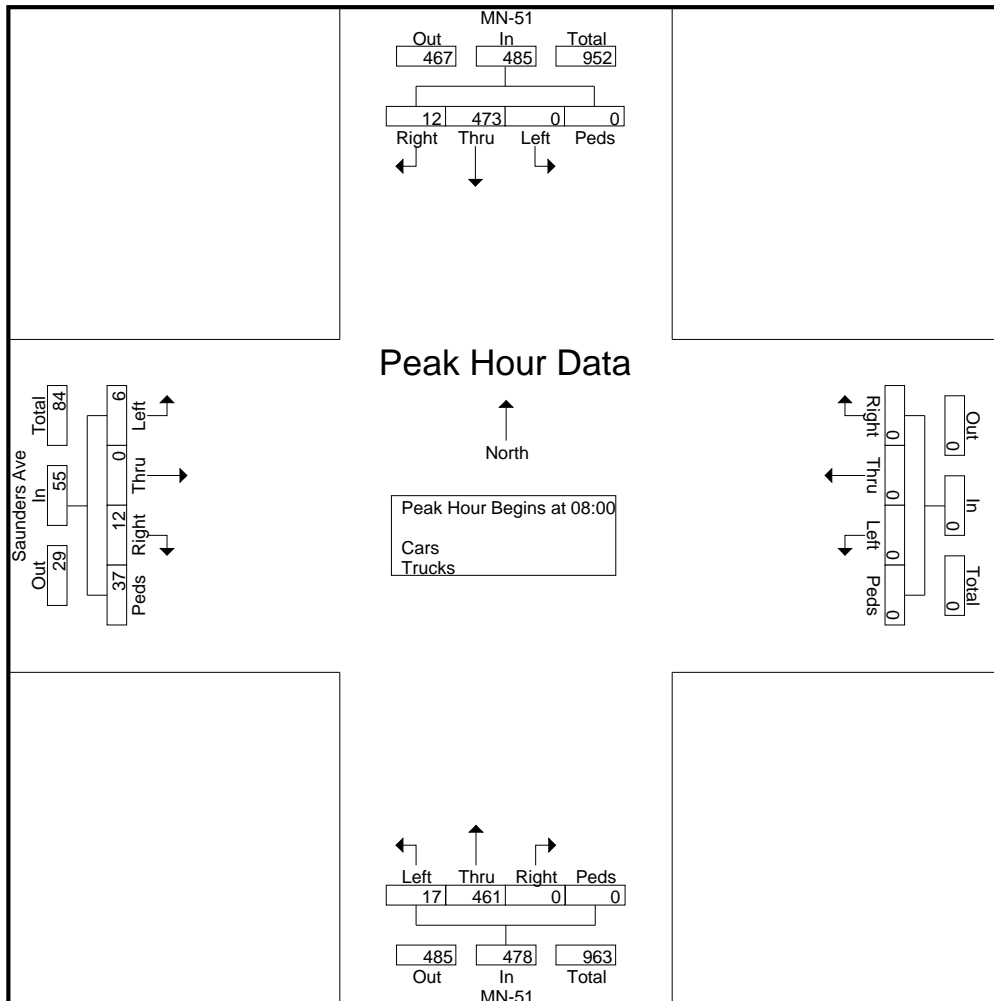

Associated Consulting Services (ACS)
 Roseville, MN 55113
 -- TRAFFIC DATA --

MN-51 at Saunders Ave_2022
 City: St Paul
 Data Prepared By: ACS
 TURNING MOVEMENT COUNT

File Name : MN-51 at Saunders Ave_2022
 Site Code :
 Start Date : 5/11/2022
 Page No : 4

Start Time	MN-51 Southbound					Westbound					MN-51 Northbound					Saunders Ave Eastbound					Int. Total
	Left	Thru	Right	Peds	App. Total	Left	Thru	Right	Peds	App. Total	Left	Thru	Right	Peds	App. Total	Left	Thru	Right	Peds	App. Total	
Peak Hour Analysis From 12:00 to 17:45 - Peak 1 of 1																					
Peak Hour for Entire Intersection Begins at 16:00																					
16:00	0	145	4	0	149	0	0	0	0	0	1	154	0	0	155	20	0	18	0	38	342
16:15	0	152	2	0	154	0	0	0	0	0	1	138	0	0	139	10	0	17	9	36	329
16:30	0	152	1	0	153	0	0	0	0	0	1	145	0	2	148	5	0	4	10	19	320
16:45	0	153	2	0	155	0	0	0	0	0	2	148	0	0	150	3	0	3	2	8	313
Total Volume	0	602	9	0	611	0	0	0	0	0	5	585	0	2	592	38	0	42	21	101	1304
% App. Total	0	98.5	1.5	0		0	0	0	0		0.8	98.8	0	0.3		37.6	0	41.6	20.8		
PHF	.000	.984	.563	.000	.985	.000	.000	.000	.000	.000	.625	.950	.000	.250	.955	.475	.000	.583	.525	.664	.953

