

SEH CONSULTING  
Traffic Data Collection  
TURN MOVEMENT COUNT

Co.Rd.C at E Snelling Drive  
Ref.Pt.: E of TH-51 /Snelling Ave.  
data by SEH  
TURN MOVEMENT COUNT

File Name : CoRd C at E Snelling Drive 2008  
Site Code : 00000022  
Start Date : 11/20/2008  
Page No : 1

Groups Printed- Unshifted - Heavy Veh

Start Time	E Snelling Drive Southbound				Co.Rd. C Westbound				commercial entrance Northbound				Co.Rd. C Eastbound				Int. Total
	Left	Thru	Right	Peds	Left	Thru	Right	Peds	Left	Thru	Right	Peds	Left	Thru	Right	Peds	
06:00	0	0	5	0	2	25	5	0	0	0	0	0	7	18	2	0	64
06:15	1	0	1	0	3	29	9	0	2	0	0	0	11	19	1	0	76
06:30	2	0	4	0	0	49	8	0	0	0	2	0	19	24	3	0	111
06:45	2	0	0	0	3	53	10	1	1	0	0	0	17	18	2	0	107
Total	5	0	10	0	8	156	32	1	3	0	2	0	54	79	8	0	358
07:00	1	1	6	1	0	75	16	0	2	0	1	0	27	33	0	0	163
07:15	3	0	7	0	1	114	23	1	1	0	0	1	29	26	1	0	207
07:30	2	0	9	1	1	121	30	0	0	0	1	0	29	27	3	0	224
07:45	5	0	13	0	1	142	36	0	0	0	0	0	24	43	2	0	266
Total	11	1	35	2	3	452	105	1	3	0	2	1	109	129	6	0	860
08:00	3	0	3	0	1	116	20	0	0	0	0	0	37	31	0	0	211
08:15	5	0	12	0	2	91	28	0	1	0	1	0	45	35	3	0	223
08:30	8	0	14	0	0	70	12	0	2	1	0	0	40	41	2	0	190
08:45	6	0	13	0	0	69	18	0	0	1	1	0	34	45	0	0	187
Total	22	0	42	0	3	346	78	0	3	2	2	0	156	152	5	0	811
*** BREAK ***																	
11:00	16	0	49	0	0	62	14	0	0	0	1	0	38	62	1	0	243
11:15	19	0	36	0	1	85	26	1	4	0	1	1	61	55	2	0	292
11:30	17	0	44	0	0	68	22	0	1	0	0	0	77	65	0	0	294
11:45	17	0	54	0	1	76	22	0	2	0	1	0	63	42	3	0	281
Total	69	0	183	0	2	291	84	1	7	0	3	1	239	224	6	0	1110
12:00	16	0	69	1	0	77	20	0	1	0	0	0	69	62	2	0	317
12:15	19	0	59	0	0	92	16	0	0	0	0	0	61	55	2	0	304
12:30	21	0	65	1	0	91	22	0	3	0	4	0	52	53	5	0	317
12:45	16	0	57	0	1	71	26	0	1	0	0	0	54	60	3	0	289
Total	72	0	250	2	1	331	84	0	5	0	4	0	236	230	12	0	1227
*** BREAK ***																	
15:00	19	0	36	0	3	86	10	0	2	2	1	0	41	77	2	0	279
15:15	28	0	38	0	0	78	11	0	2	1	0	0	34	76	3	0	271
15:30	16	0	42	0	0	113	15	1	2	5	2	0	31	84	2	0	313
15:45	24	0	46	0	1	68	22	1	2	2	1	0	39	90	1	0	297
Total	87	0	162	0	4	345	58	2	8	10	4	0	145	327	8	0	1160
16:00	37	0	44	0	0	67	17	0	1	4	0	0	39	114	0	0	323
16:15	38	0	33	0	0	69	23	0	1	3	0	0	39	114	2	0	322
16:30	40	0	47	0	0	86	18	0	0	0	1	0	26	147	0	0	365
16:45	28	0	55	1	1	95	24	0	0	1	0	0	46	161	1	0	413
Total	143	0	179	1	1	317	82	0	2	8	1	0	150	536	3	0	1423
17:00	31	0	52	0	0	128	22	0	2	0	1	0	39	167	0	0	442
17:15	21	0	49	1	0	77	20	0	1	0	0	0	41	152	1	0	363
17:30	21	0	31	0	0	81	17	0	0	0	1	0	51	175	0	0	377
17:45	24	0	40	1	0	92	20	0	0	0	0	0	40	156	0	0	373
Total	97	0	172	2	0	378	79	0	3	0	2	0	171	650	1	0	1555
Grand Total	506	1	1033	7	22	2616	602	5	34	20	20	2	1260	2327	49	0	8504
Apprch %	32.7	0.1	66.8	0.5	0.7	80.6	18.6	0.2	44.7	26.3	26.3	2.6	34.7	64	1.3	0	
Total %	6	0	12.1	0.1	0.3	30.8	7.1	0.1	0.4	0.2	0.2	0	14.8	27.4	0.6	0	
Unshifted	506	1	1032	7	22	2586	602	5	33	20	20	2	1260	2298	48	0	8442
% Unshifted	100	100	99.9	100	100	98.9	100	100	97.1	100	100	100	100	98.8	98	0	99.3
Heavy Veh	0	0	1	0	0	30	0	0	1	0	0	0	0	29	1	0	62
% Heavy Veh	0	0	0.1	0	0	1.1	0	0	2.9	0	0	0	0	1.2	2	0	0.7

SEH CONSULTING  
Traffic Data Collection  
TURN MOVEMENT COUNT

Co.Rd.C at E Snelling Drive  
Ref.Pt.: E of TH-51 /Snelling Ave.  
data by SEH  
TURN MOVEMENT COUNT

File Name : CoRd C at E Snelling Drive 2008  
Site Code : 00000022  
Start Date : 11/20/2008  
Page No : 2

Start Time	E Snelling Drive Southbound					Co.Rd. C Westbound					commercial entrance Northbound					Co.Rd. C Eastbound					Int. Total
	Left	Thru	Right	Peds	App. Total	Left	Thru	Right	Peds	App. Total	Left	Thru	Right	Peds	App. Total	Left	Thru	Right	Peds	App. Total	
Peak Hour Analysis From 06:00 to 08:45 - Peak 1 of 1																					
Peak Hour for Entire Intersection Begins at 07:30																					
07:30	2	0	9	1	12	1	121	30	0	152	0	0	1	0	1	29	27	3	0	59	224
07:45	5	0	13	0	18	1	142	36	0	179	0	0	0	0	0	24	43	2	0	69	266
08:00	3	0	3	0	6	1	116	20	0	137	0	0	0	0	0	37	31	0	0	68	211
08:15	5	0	12	0	17	2	91	28	0	121	1	0	1	0	2	45	35	3	0	83	223
Total Volume	15	0	37	1	53	5	470	114	0	589	1	0	2	0	3	135	136	8	0	279	924
% App. Total	28.3	0	69.8	1.9		0.8	79.8	19.4	0		33.3	0	66.7	0		48.4	48.7	2.9	0		
PHF	.750	.000	.712	.250	.736	.625	.827	.792	.000	.823	.250	.000	.500	.000	.375	.750	.791	.667	.000	.840	.868

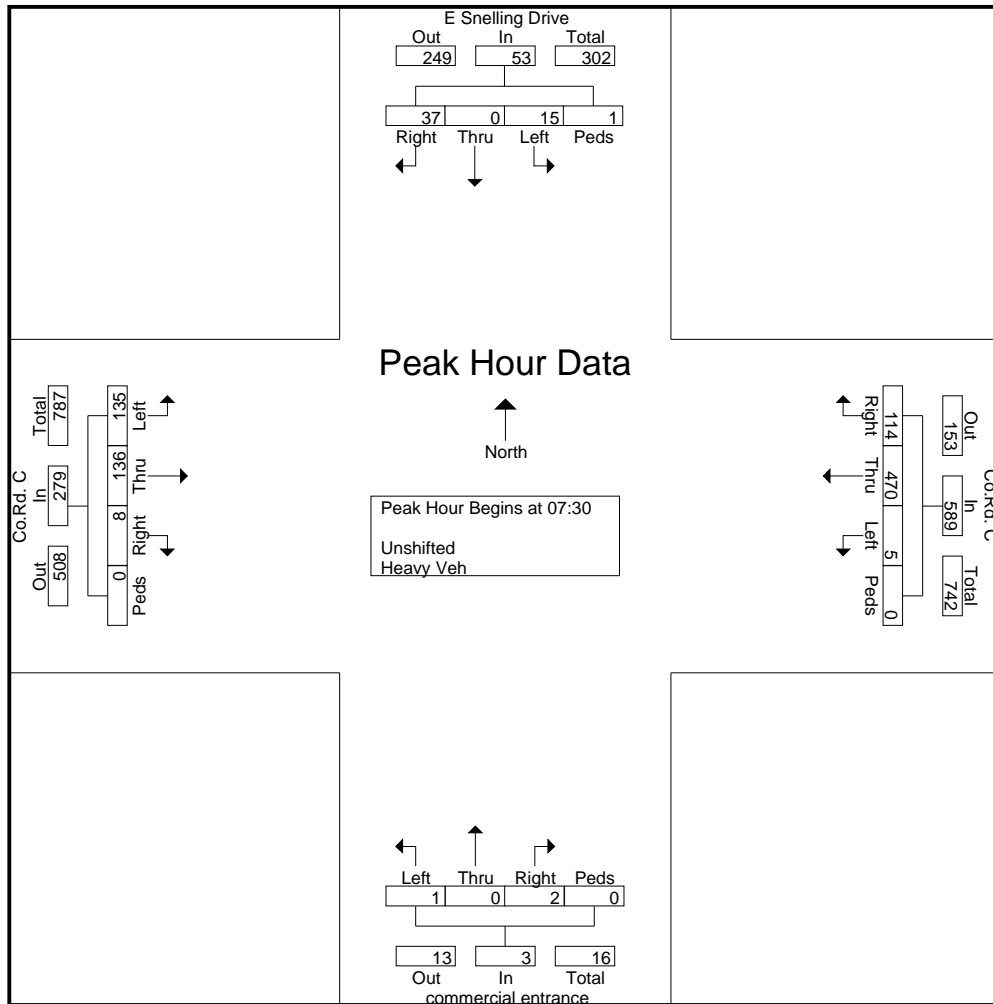

SEH CONSULTING  
Traffic Data Collection  
TURN MOVEMENT COUNT

Co.Rd.C at E Snelling Drive  
Ref.Pt.: E of TH-51 /Snelling Ave.  
data by SEH  
TURN MOVEMENT COUNT

File Name : CoRd C at E Snelling Drive 2008  
Site Code : 0000022  
Start Date : 11/20/2008  
Page No : 3

Start Time	E Snelling Drive Southbound					Co.Rd. C Westbound					commercial entrance Northbound					Co.Rd. C Eastbound					Int. Total
	Left	Thru	Right	Peds	App. Total	Left	Thru	Right	Peds	App. Total	Left	Thru	Right	Peds	App. Total	Left	Thru	Right	Peds	App. Total	

Peak Hour Analysis From 15:00 to 17:45 - Peak 1 of 1

Peak Hour for Entire Intersection Begins at 16:45

16:45	28	0	55	1	84	1	95	24	0	120	0	1	0	0	1	46	161	1	0	208	413
17:00	31	0	52	0	83	0	128	22	0	150	2	0	1	0	3	39	167	0	0	206	442
17:15	21	0	49	1	71	0	77	20	0	97	1	0	0	0	1	41	152	1	0	194	363
17:30	21	0	31	0	52	0	81	17	0	98	0	0	1	0	1	51	175	0	0	226	377
Total Volume	101	0	187	2	290	1	381	83	0	465	3	1	2	0	6	177	655	2	0	834	1595
% App. Total	34.8	0	64.5	0.7		0.2	81.9	17.8	0		50	16.7	33.3	0		21.2	78.5	0.2	0		
PHF	.815	.000	.850	.500	.863	.250	.744	.865	.000	.775	.375	.250	.500	.000	.500	.868	.936	.500	.000	.923	.902

