

# Alliant Engineering Inc Minneapolis, MN 55415

Douglas Drive at N Frontage Rd.  
Ref.Pt.: north of TH-55  
Alliant Engineering Inc  
TURN MOVEMENT COUNT

File Name : 64\_Douglas Dr at North Frontage Rd\_011811  
Site Code : 00000064  
Start Date : 1/18/2011  
Page No : 1

### Groups Printed- Unshifted - Bank 1

Start Time	Douglas Drive / Co.Rd.102 Southbound				N Frontage Rd Westbound				Douglas Drive / Co.Rd.102 Northbound				N Frontage Rd Eastbound				Int. Total
	Left	Thru	Right	Peds	Left	Thru	Right	Peds	Left	Thru	Right	Peds	Left	Thru	Right	Peds	
06:00	1	32	1	0	13	0	0	0	12	20	12	0	0	0	1	0	92
06:15	1	21	3	0	5	0	0	0	26	26	21	2	0	0	1	0	106
06:30	1	41	4	0	1	0	0	0	38	42	23	0	0	0	1	0	151
06:45	5	63	13	0	0	0	0	0	57	46	32	1	1	0	1	0	219
Total	8	157	21	0	19	0	0	0	133	134	88	3	1	0	4	0	568
07:00	3	80	17	0	5	0	1	0	70	50	17	0	0	0	1	0	244
07:15	7	96	29	0	7	0	2	0	97	69	23	0	1	0	4	0	335
07:30	3	111	38	2	5	0	2	0	126	63	33	0	0	0	5	0	388
07:45	7	109	50	0	9	0	0	0	131	63	41	2	0	0	1	0	413
Total	20	396	134	2	26	0	5	0	424	245	114	2	1	0	11	0	1380
08:00	5	107	33	0	4	1	1	0	144	69	35	4	0	0	4	0	407
08:15	10	94	26	0	7	0	2	0	136	49	24	0	1	0	3	0	352
08:30	4	69	14	3	8	1	2	3	117	56	23	0	0	0	3	0	303
08:45	4	66	16	0	11	0	2	0	93	59	24	0	0	0	5	0	280
Total	23	336	89	3	30	2	7	3	490	233	106	4	1	0	15	0	1342
09:00	4	65	9	0	16	0	3	0	57	58	25	0	1	0	6	0	244
09:15	3	50	4	0	9	0	2	0	44	42	12	0	0	0	2	0	168
*** BREAK ***																	
Total	7	115	13	0	25	0	5	0	101	100	37	0	1	0	8	0	412
*** BREAK ***																	
10:30	4	37	2	0	13	0	6	0	13	31	14	0	2	0	8	0	130
10:45	1	47	1	0	9	0	9	0	6	32	11	0	3	0	7	0	126
Total	5	84	3	0	22	0	15	0	19	63	25	0	5	0	15	0	256
11:00	2	45	7	0	15	0	6	0	9	24	17	0	6	1	15	0	147
11:15	0	49	5	0	26	0	6	0	14	42	14	0	4	0	14	0	174
11:30	2	41	2	1	36	0	2	0	10	38	21	0	6	0	10	0	169
11:45	5	48	10	0	17	1	3	0	13	39	22	0	6	0	21	0	185
Total	9	183	24	1	94	1	17	0	46	143	74	0	22	1	60	0	675
12:00	6	44	4	0	25	0	6	0	12	41	20	0	9	0	15	0	182
12:15	4	45	7	0	15	0	6	0	15	52	14	0	2	1	12	0	173
12:30	5	53	6	0	7	1	2	0	13	45	12	0	3	1	10	0	158
12:45	8	46	5	0	11	0	9	0	27	44	29	1	2	0	8	0	190
Total	23	188	22	0	58	1	23	0	67	182	75	1	16	2	45	0	703
13:00	10	43	6	0	18	0	6	0	17	47	17	0	1	0	12	0	177
13:15	3	43	5	0	10	1	3	0	13	58	25	0	0	0	7	0	168
*** BREAK ***																	
Total	13	86	11	0	28	1	9	0	30	105	42	0	1	0	19	0	345
*** BREAK ***																	
14:30	4	72	3	0	14	1	0	0	11	45	8	0	0	0	11	0	169
14:45	6	58	2	0	9	0	10	0	9	62	19	0	3	0	17	0	195
Total	10	130	5	0	23	1	10	0	20	107	27	0	3	0	28	0	364
15:00	2	61	6	0	27	0	2	0	7	49	10	0	7	1	29	0	201
15:15	0	48	1	0	39	0	3	0	7	57	12	1	6	1	11	0	186
15:30	4	72	0	0	26	0	5	0	9	74	8	0	15	0	32	0	245
15:45	1	56	2	0	21	0	5	0	8	71	9	0	6	0	37	0	216
Total	7	237	9	0	113	0	15	0	31	251	39	1	34	2	109	0	848

# Alliant Engineering Inc Minneapolis, MN 55415

Douglas Drive at N Frontage Rd.  
Ref.Pt.: north of TH-55  
Alliant Engineering Inc  
TURN MOVEMENT COUNT

File Name : 64\_Douglas Dr at North Frontage Rd\_011811  
Site Code : 00000064  
Start Date : 1/18/2011  
Page No : 2

### Groups Printed- Unshifted - Bank 1

Start Time	Douglas Drive / Co.Rd.102 Southbound				N Frontage Rd Westbound				Douglas Drive / Co.Rd.102 Northbound				N Frontage Rd Eastbound				Int. Total
	Left	Thru	Right	Peds	Left	Thru	Right	Peds	Left	Thru	Right	Peds	Left	Thru	Right	Peds	
16:00	4	82	3	0	25	1	6	0	8	85	7	0	25	0	58	0	304
16:15	2	63	3	1	22	0	1	0	7	98	7	0	24	0	62	0	290
16:30	2	64	1	0	31	0	2	0	4	81	6	0	35	0	87	2	315
16:45	2	52	2	0	25	0	1	0	6	131	3	0	35	0	114	0	371
Total	10	261	9	1	103	1	10	0	25	395	23	0	119	0	321	2	1280
17:00	0	70	2	0	37	0	2	0	1	107	9	0	38	2	114	0	382
17:15	0	48	1	0	16	0	3	0	0	117	5	0	23	0	102	0	315
17:30	0	51	0	0	21	0	0	0	2	104	3	0	26	1	89	0	297
17:45	0	57	1	0	14	0	1	0	4	92	1	0	9	0	67	0	246
Total	0	226	4	0	88	0	6	0	7	420	18	0	96	3	372	0	1240
Grand Total	135	2399	344	7	629	7	122	3	1393	2378	668	11	300	8	1007	2	9413
Apprch %	4.7	83.2	11.9	0.2	82.7	0.9	16	0.4	31.3	53.4	15	0.2	22.8	0.6	76.5	0.2	
Total %	1.4	25.5	3.7	0.1	6.7	0.1	1.3	0	14.8	25.3	7.1	0.1	3.2	0.1	10.7	0	
Unshifted	134	2388	342	7	622	7	121	3	1392	2347	660	11	299	7	1001	2	9343
% Unshifted	99.3	99.5	99.4	100	98.9	100	99.2	100	99.9	98.7	98.8	100	99.7	87.5	99.4	100	99.3
Bank 1	1	11	2	0	7	0	1	0	1	31	8	0	1	1	6	0	70
% Bank 1	0.7	0.5	0.6	0	1.1	0	0.8	0	0.1	1.3	1.2	0	0.3	12.5	0.6	0	0.7

# Alliant Engineering Inc Minneapolis, MN 55415

Douglas Drive at N Frontage Rd.  
Ref.Pt.: north of TH-55  
Alliant Engineering Inc  
TURN MOVEMENT COUNT

File Name : 64\_Douglas Dr at North Frontage Rd\_011811  
Site Code : 00000064  
Start Date : 1/18/2011  
Page No : 3

Start Time	Douglas Drive / Co.Rd.102 Southbound					N Frontage Rd Westbound					Douglas Drive / Co.Rd.102 Northbound					N Frontage Rd Eastbound					Int. Total
	Left	Thru	Right	Peds	App. Total	Left	Thru	Right	Peds	App. Total	Left	Thru	Right	Peds	App. Total	Left	Thru	Right	Peds	App. Total	
Peak Hour Analysis From 06:00 to 09:15 - Peak 1 of 1																					
Peak Hour for Entire Intersection Begins at 07:30																					
07:30	3	111	38	2	154	5	0	2	0	7	126	63	33	0	222	0	0	5	0	5	388
07:45	7	109	50	0	166	9	0	0	0	9	131	63	41	2	237	0	0	1	0	1	413
08:00	5	107	33	0	145	4	1	1	0	6	144	69	35	4	252	0	0	4	0	4	407
08:15	10	94	26	0	130	7	0	2	0	9	136	49	24	0	209	1	0	3	0	4	352
Total Volume	25	421	147	2	595	25	1	5	0	31	537	244	133	6	920	1	0	13	0	14	1560
% App. Total	4.2	70.8	24.7	0.3		80.6	3.2	16.1	0		58.4	26.5	14.5	0.7		7.1	0	92.9	0		
PHF	.625	.948	.735	.250	.896	.694	.250	.625	.000	.861	.932	.884	.811	.375	.913	.250	.000	.650	.000	.700	.944

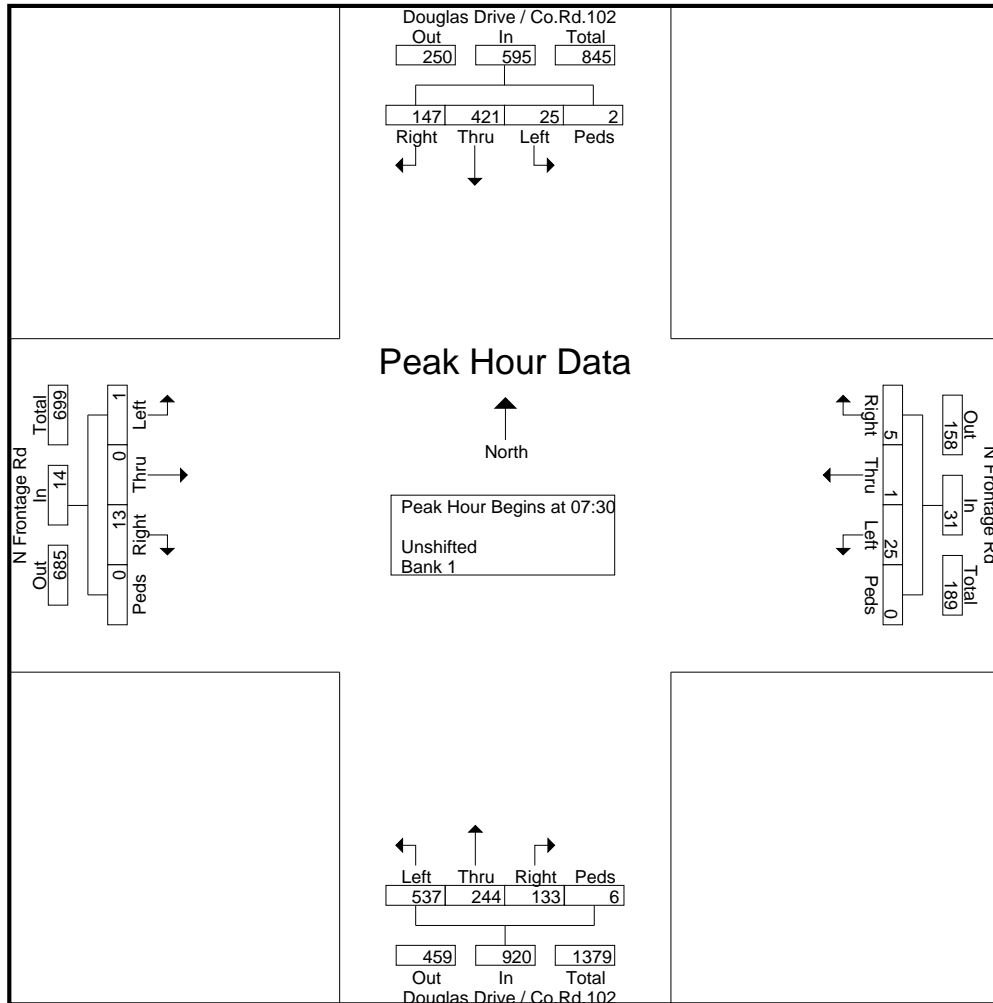

# Alliant Engineering Inc Minneapolis, MN 55415

Douglas Drive at N Frontage Rd.  
Ref.Pt.: north of TH-55  
Alliant Engineering Inc  
TURN MOVEMENT COUNT

File Name : 64\_Douglas Dr at North Frontage Rd\_011811  
Site Code : 00000064  
Start Date : 1/18/2011  
Page No : 4

Start Time	Douglas Drive / Co.Rd.102 Southbound					N Frontage Rd Westbound					Douglas Drive / Co.Rd.102 Northbound					N Frontage Rd Eastbound					Int. Total
	Left	Thru	Right	Peds	App. Total	Left	Thru	Right	Peds	App. Total	Left	Thru	Right	Peds	App. Total	Left	Thru	Right	Peds	App. Total	
Peak Hour Analysis From 14:30 to 17:45 - Peak 1 of 1																					
Peak Hour for Entire Intersection Begins at 16:30																					
16:30	2	64	1	0	67	31	0	2	0	33	4	81	6	0	91	35	0	87	2	124	315
16:45	2	52	2	0	56	25	0	1	0	26	6	131	3	0	140	35	0	114	0	149	371
17:00	0	70	2	0	72	37	0	2	0	39	1	107	9	0	117	38	2	114	0	154	382
17:15	0	48	1	0	49	16	0	3	0	19	0	117	5	0	122	23	0	102	0	125	315
Total Volume	4	234	6	0	244	109	0	8	0	117	11	436	23	0	470	131	2	417	2	552	1383
% App. Total	1.6	95.9	2.5	0		93.2	0	6.8	0		2.3	92.8	4.9	0		23.7	0.4	75.5	0.4		
PHF	.500	.836	.750	.000	.847	.736	.000	.667	.000	.750	.458	.832	.639	.000	.839	.862	.250	.914	.250	.896	.905

