

# Alliant Engineering

Minneapolis, MN 55415

--TRAFFIC DATA --

TH-13 at TH-55

File Name : 103 - TH 55 & TH 13

Site Code : 103

BY: Alliant Eng.

Start Date : 11/18/2014

TURN MOVEMENT COUNT

Page No : 1

Groups Printed- Cars - Trucks

Start Time	TH 13 Southbound				TH 55 Westbound				TH 13 Northbound				TH 55 Eastbound				Int. Total
	Left	Thru	Rght	Bikes	Left	Thru	Rght	Bikes	Left	Thru	Rght	Bikes	Left	Thru	Rght	Bikes	
06:00	3	4	1	0	4	157	1	0	44	5	0	0	0	124	22	0	365
06:15	2	2	1	0	2	251	3	0	71	6	1	0	0	175	24	0	538
06:30	1	5	3	0	1	280	5	0	63	9	7	0	1	231	23	0	629
06:45	3	9	2	0	3	316	3	0	92	16	5	0	0	305	50	0	804
Total	9	20	7	0	10	1004	12	0	270	36	13	0	1	835	119	0	2336
07:00	3	4	0	0	2	354	4	0	130	17	4	0	0	228	50	0	796
07:15	5	10	6	0	11	373	6	0	146	29	4	0	0	345	48	0	983
07:30	6	7	0	0	5	414	5	0	145	31	19	0	2	323	57	0	1014
07:45	3	14	1	1	13	343	7	0	172	42	4	0	2	319	68	0	989
Total	17	35	7	1	31	1484	22	0	593	119	31	0	4	1215	223	0	3782
08:00	5	7	1	0	6	298	4	0	121	41	8	0	1	347	69	0	908
08:15	8	7	2	0	5	273	4	0	103	25	17	0	2	336	66	0	848
08:30	3	11	0	0	5	234	7	0	75	27	15	0	2	263	62	0	704
08:45	7	5	5	0	9	186	7	0	59	10	9	0	2	267	73	0	639
Total	23	30	8	0	25	991	22	0	358	103	49	0	7	1213	270	0	3099
09:00	2	7	4	0	10	161	4	0	44	11	6	0	0	184	51	0	484
09:15	6	6	1	0	3	195	2	0	45	10	9	0	0	184	40	0	501
*** BREAK ***																	
Total	8	13	5	0	13	356	6	0	89	21	15	0	0	368	91	0	985
*** BREAK ***																	
10:30	4	12	0	0	10	120	3	0	34	8	8	0	2	128	30	0	359
10:45	6	13	2	0	7	117	7	0	28	13	12	0	1	135	28	0	369
Total	10	25	2	0	17	237	10	0	62	21	20	0	3	263	58	0	728
11:00	4	15	3	0	10	120	4	0	33	7	10	0	0	112	31	0	349
11:15	2	8	1	0	5	113	4	0	28	10	9	0	0	111	40	0	331
11:30	3	6	2	0	11	137	7	0	36	9	7	0	1	114	20	0	353
11:45	10	10	3	0	5	142	8	0	26	10	3	0	2	117	34	0	370
Total	19	39	9	0	31	512	23	0	123	36	29	0	3	454	125	0	1403
12:00	6	8	1	0	6	118	3	0	32	7	6	0	0	138	30	0	355
12:15	6	7	5	0	8	118	10	0	39	13	2	0	1	124	46	0	379
12:30	9	11	2	0	3	132	11	0	34	11	6	0	3	147	37	0	406
12:45	4	6	0	0	3	114	4	0	28	13	13	0	2	134	35	0	356
Total	25	32	8	0	20	482	28	0	133	44	27	0	6	543	148	0	1496
13:00	5	9	0	0	4	154	5	0	28	12	9	0	7	116	34	0	383
13:15	6	14	0	0	5	109	3	0	27	8	5	0	0	140	41	0	358
*** BREAK ***																	
Total	11	23	0	0	9	263	8	0	55	20	14	0	7	256	75	0	741
*** BREAK ***																	
14:30	5	14	0	0	9	154	13	0	62	26	4	0	2	167	34	0	490
14:45	3	5	0	0	10	194	7	0	51	19	3	0	1	195	50	0	538
Total	8	19	0	0	19	348	20	0	113	45	7	0	3	362	84	0	1028
15:00	4	14	2	0	10	246	8	0	41	21	4	0	0	203	57	0	610
15:15	3	14	4	0	8	202	8	0	38	15	18	0	2	239	85	0	636
15:30	1	12	1	0	8	320	3	0	65	28	8	0	3	238	78	0	765
15:45	5	12	1	0	11	250	6	0	56	15	7	0	2	240	87	0	692
Total	13	52	8	0	37	1018	25	0	200	79	37	0	7	920	307	0	2703
16:00	0	11	2	0	5	358	15	0	63	14	6	0	2	250	81	0	807
16:15	7	11	6	0	5	289	3	0	70	26	12	0	0	306	107	0	842
16:30	2	17	0	0	4	363	9	0	96	26	7	0	0	342	116	0	982

# Alliant Engineering

Minneapolis, MN 55415

--TRAFFIC DATA --

TH-13 at TH-55

File Name : 103 - TH 55 & TH 13

Site Code : 103

BY: Alliant Eng.

Start Date : 11/18/2014

TURN MOVEMENT COUNT

Page No : 2

Groups Printed- Cars - Trucks

Start Time	TH 13 Southbound				TH 55 Westbound				TH 13 Northbound				TH 55 Eastbound				Int. Total
	Left	Thru	Rght	Bikes	Left	Thru	Rght	Bikes	Left	Thru	Rght	Bikes	Left	Thru	Rght	Bikes	
16:45	5	12	2	0	5	302	12	0	83	41	6	0	5	274	138	0	885
Total	14	51	10	0	19	1312	39	0	312	107	31	0	7	1172	442	0	3516
17:00	2	19	2	0	13	331	14	0	111	20	5	0	1	289	122	0	929
17:15	2	20	1	0	10	339	11	0	77	22	10	1	0	294	130	0	917
17:30	2	18	2	0	8	299	10	0	71	23	9	0	1	268	107	0	818
17:45	2	8	1	0	6	269	10	0	49	21	4	0	0	266	77	0	713
Total	8	65	6	0	37	1238	45	0	308	86	28	1	2	1117	436	0	3377
Grand Total	165	404	70	1	268	9245	260	0	2616	717	301	1	50	8718	2378	0	25194
Apprch %	25.8	63.1	10.9	0.2	2.7	94.6	2.7	0	72	19.7	8.3	0	0.4	78.2	21.3	0	
Total %	0.7	1.6	0.3	0	1.1	36.7	1	0	10.4	2.8	1.2	0	0.2	34.6	9.4	0	
Cars	157	391	69	0	229	8791	247	0	2537	705	235	0	47	8112	2293	0	23813
% Cars	95.2	96.8	98.6	0	85.4	95.1	95	0	97	98.3	78.1	0	94	93	96.4	0	94.5
Trucks	8	13	1	1	39	454	13	0	79	12	66	1	3	606	85	0	1381
% Trucks	4.8	3.2	1.4	100	14.6	4.9	5	0	3	1.7	21.9	100	6	7	3.6	0	5.5

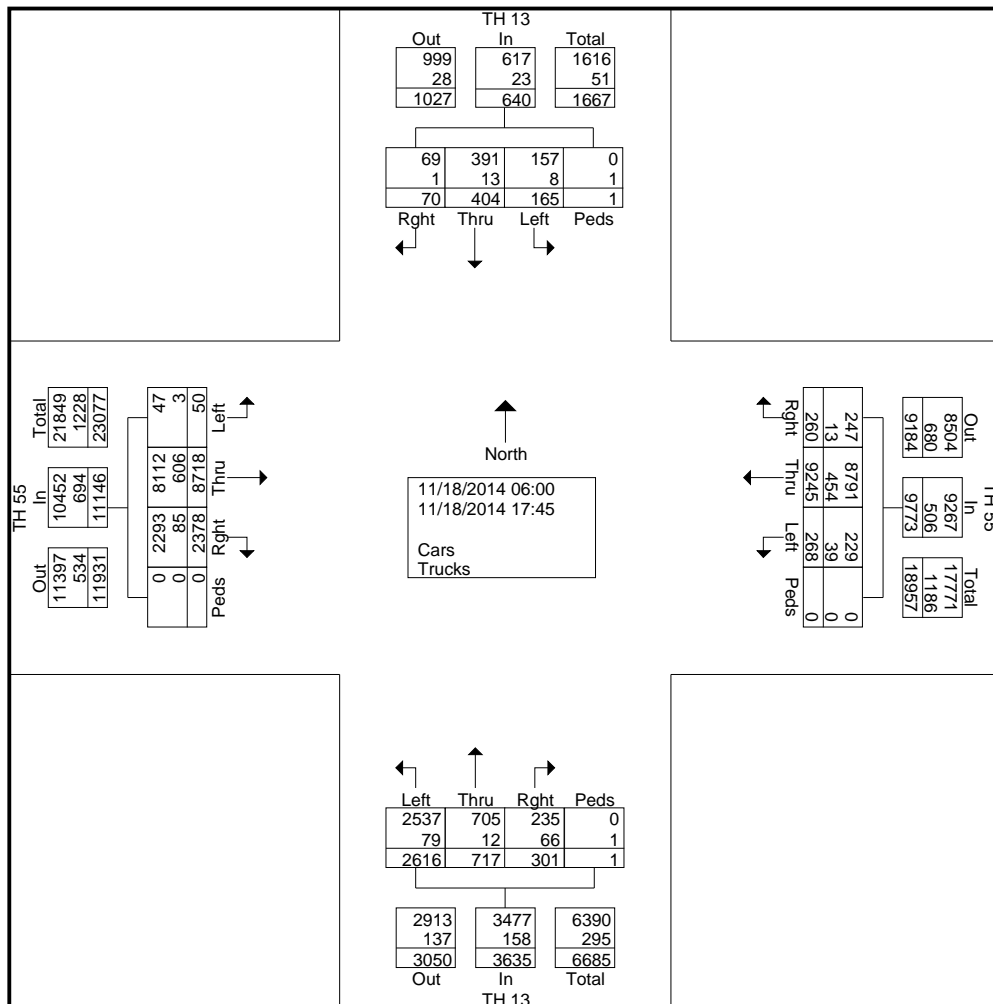

# Alliant Engineering

Minneapolis, MN 55415  
--TRAFFIC DATA --

TH-13 at TH-55

File Name : 103 - TH 55 & TH 13

BY: Alliant Eng.  
TURN MOVEMENT COUNT

Site Code : 103  
Start Date : 11/18/2014  
Page No : 3

Start Time	TH 13 Southbound					TH 55 Westbound					TH 13 Northbound					TH 55 Eastbound					Int. Total
	Left	Thru	Right	Bikes	App. Total	Left	Thru	Right	Bikes	App. Total	Left	Thru	Right	Bikes	App. Total	Left	Thru	Right	Bikes	App. Total	
Peak Hour Analysis From 06:00 to 11:45 - Peak 1 of 1																					
Peak Hour for Entire Intersection Begins at 07:15																					
07:15	5	10	6	0	21	11	373	6	0	390	146	29	4	0	179	0	345	48	0	393	983
07:30	6	7	0	0	13	5	414	5	0	424	145	31	19	0	195	2	323	57	0	382	1014
07:45	3	14	1	1	19	13	343	7	0	363	172	42	4	0	218	2	319	68	0	389	989
08:00	5	7	1	0	13	6	298	4	0	308	121	41	8	0	170	1	347	69	0	417	908
Total Volume	19	38	8	1	66	35	1428	22	0	1485	584	143	35	0	762	5	1334	242	0	1581	3894
% App. Total	28.8	57.6	12.1	1.5		2.4	96.2	1.5	0		76.6	18.8	4.6	0		0.3	84.4	15.3	0		
PHF	.792	.679	.333	.250	.786	.673	.862	.786	.000	.876	.849	.851	.461	.000	.874	.625	.961	.877	.000	.948	.960

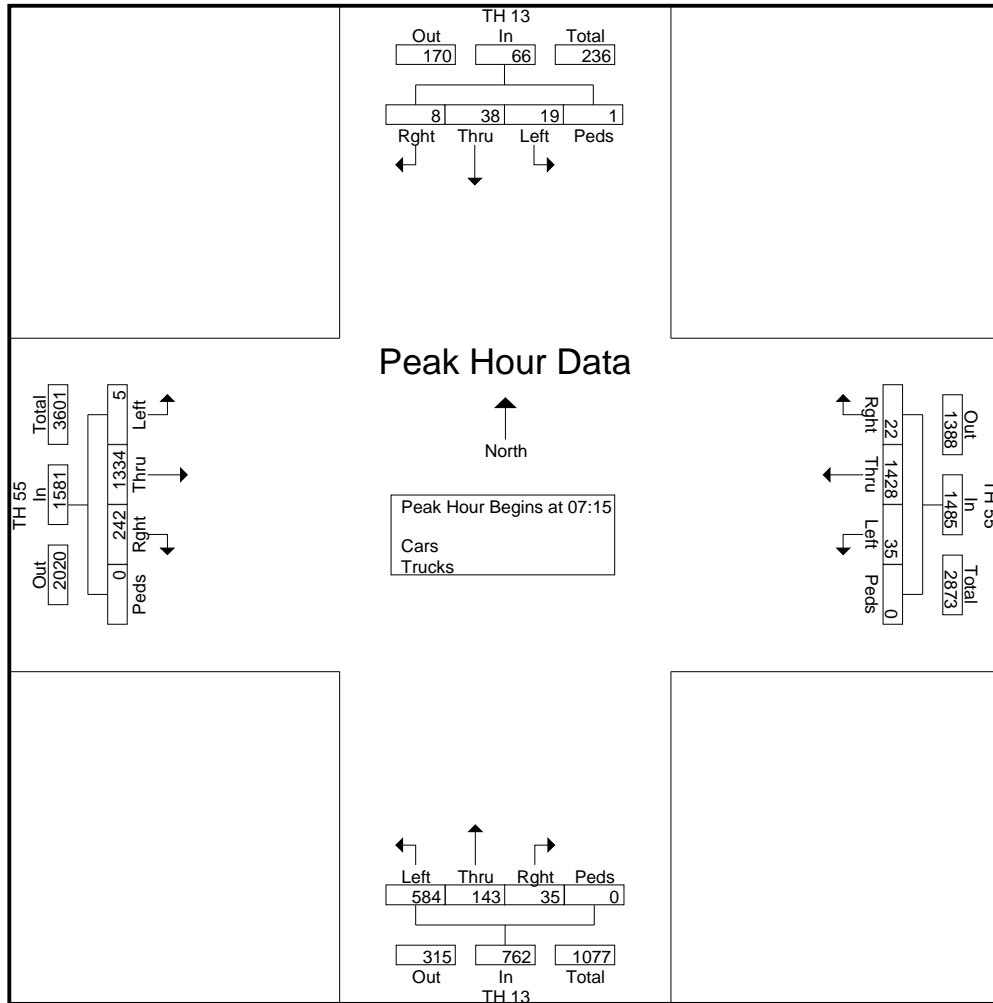

# Alliant Engineering

Minneapolis, MN 55415

--TRAFFIC DATA --

TH-13 at TH-55

File Name : 103 - TH 55 & TH 13

Site Code : 103

BY: Alliant Eng.

Start Date : 11/18/2014

TURN MOVEMENT COUNT

Page No : 4

Start Time	TH 13 Southbound					TH 55 Westbound					TH 13 Northbound					TH 55 Eastbound					Int. Total
	Left	Thru	Rght	Bikes	App. Total	Left	Thru	Rght	Bikes	App. Total	Left	Thru	Rght	Bikes	App. Total	Left	Thru	Rght	Bikes	App. Total	
Peak Hour Analysis From 12:00 to 17:45 - Peak 1 of 1																					
Peak Hour for Entire Intersection Begins at 16:30																					
16:30	2	17	0	0	19	4	363	9	0	376	96	26	7	0	129	0	342	116	0	458	982
16:45	5	12	2	0	19	5	302	12	0	319	83	41	6	0	130	5	274	138	0	417	885
17:00	2	19	2	0	23	13	331	14	0	358	111	20	5	0	136	1	289	122	0	412	929
17:15	2	20	1	0	23	10	339	11	0	360	77	22	10	1	110	0	294	130	0	424	917
Total Volume	11	68	5	0	84	32	1335	46	0	1413	367	109	28	1	505	6	1199	506	0	1711	3713
% App. Total	13.1	81	6	0		2.3	94.5	3.3	0		72.7	21.6	5.5	0.2		0.4	70.1	29.6	0		
PHF	.550	.850	.625	.000	.913	.615	.919	.821	.000	.939	.827	.665	.700	.250	.928	.300	.876	.917	.000	.934	.945

