



MINNESOTA DEPT OF TRANSPORTATION
TRAFFIC DATA COLLECTION - METRO

MN-55 AT LONE OAK RD / CSAH-26
REF.PT.: 202.512
DATA COLLECTED BY TDI
TURN MOVEMENT COUNT

File Name : TH-55 AT LONE OAK RD 2007
Site Code : 00198722
Start Date : 5/17/2007
Page No : 1

Groups Printed- Unshifted

Start Time	MN-55 Southbound				LONE OAK RD / CSAH-26 Westbound				MN-55 Northbound				LONE OAK RD / CSAH-26 Eastbound				Int. Total
	Left	Thru	Right	Peds	Left	Thru	Right	Peds	Left	Thru	Right	Peds	Left	Thru	Right	Peds	
06:00	4	103	14	0	0	15	18	0	20	159	1	0	11	15	19	0	379
06:15	5	100	16	0	0	37	10	0	52	235	0	1	14	33	19	0	522
06:30	8	149	25	1	1	46	21	0	47	270	2	1	13	26	27	0	637
06:45	12	151	31	0	2	43	29	0	53	285	0	0	16	42	22	0	686
Total	29	503	86	1	3	141	78	0	172	949	3	2	54	116	87	0	2224
07:00	10	159	14	0	0	34	22	0	45	321	3	0	21	51	28	1	709
07:15	7	216	34	0	1	37	30	0	52	364	4	0	23	75	39	0	882
07:30	5	193	33	0	0	58	21	0	59	352	1	1	33	76	39	0	871
07:45	13	237	39	0	5	60	24	0	83	369	5	0	46	85	38	0	1004
Total	35	805	120	0	6	189	97	0	239	1406	13	1	123	287	144	1	3466
08:00	14	245	27	0	4	38	15	0	61	300	1	0	31	88	44	0	868
08:15	16	225	17	0	2	35	16	0	30	271	3	0	23	52	23	0	713
08:30	13	182	20	0	2	24	18	0	43	260	5	0	25	49	30	0	671
08:45	8	171	20	0	2	30	13	0	32	192	3	0	25	38	24	1	559
Total	51	823	84	0	10	127	62	0	166	1023	12	0	104	227	121	1	2811
*** BREAK ***																	
11:00	13	126	38	0	3	25	3	0	30	159	3	0	23	44	47	1	515
11:15	12	151	21	0	4	55	10	0	25	166	6	0	21	29	43	0	543
11:30	20	137	27	0	17	47	11	0	33	149	2	0	31	49	53	1	577
11:45	26	159	26	0	2	65	14	0	42	176	2	0	19	44	41	0	616
Total	71	573	112	0	26	192	38	0	130	650	13	0	94	166	184	2	2251
12:00	24	144	20	0	2	83	17	0	45	171	2	0	24	60	63	0	655
12:15	29	112	19	1	2	52	16	0	47	188	1	1	25	59	33	1	586
12:30	18	134	22	0	3	40	15	0	45	170	2	1	25	67	54	1	597
12:45	15	172	29	0	11	46	20	0	42	170	2	0	27	87	30	0	651
Total	86	562	90	1	18	221	68	0	179	699	7	2	101	273	180	2	2489
*** BREAK ***																	
15:00	7	191	24	0	1	28	13	0	32	191	5	0	35	47	46	0	620
15:15	21	223	25	0	0	27	14	0	19	209	3	0	32	40	45	0	658
15:30	16	295	23	1	2	37	7	0	25	203	5	1	38	68	81	1	803
15:45	20	286	31	0	1	48	9	0	36	181	1	0	29	49	66	0	757
Total	64	995	103	1	4	140	43	0	112	784	14	1	134	204	238	1	2838
16:00	19	299	28	0	5	49	16	0	28	235	1	0	45	64	55	0	844
16:15	10	361	23	0	4	65	9	0	21	216	0	0	26	53	56	0	844
16:30	22	343	40	0	2	91	18	0	36	209	1	1	36	64	96	0	959
16:45	15	379	45	0	11	85	14	0	31	248	1	0	30	65	73	1	998
Total	66	1382	136	0	22	290	57	0	116	908	3	1	137	246	280	1	3645
17:00	19	395	63	0	6	80	22	0	36	261	0	1	49	80	85	1	1098
17:15	15	358	63	0	7	81	10	0	36	246	0	1	21	66	66	0	970
17:30	19	368	54	0	2	63	7	0	35	255	4	0	22	35	62	0	926
17:45	21	341	43	0	1	68	15	0	43	214	3	0	26	34	42	0	851
Total	74	1462	223	0	16	292	54	0	150	976	7	2	118	215	255	1	3845



MINNESOTA DEPT OF TRANSPORTATION
 TRAFFIC DATA COLLECTION - METRO

MN-55 AT LONE OAK RD / CSAH-26
 REF.PT.: 202.512
 DATA COLLECTED BY TDI
 TURN MOVEMENT COUNT

File Name : TH-55 AT LONE OAK RD 2007
 Site Code : 00198722
 Start Date : 5/17/2007
 Page No : 2

Groups Printed- Unshifted

	MN-55 Southbound				LONE OAK RD / CSAH-26 Westbound				MN-55 Northbound				LONE OAK RD / CSAH-26 Eastbound				Int. Total
	Left	Thru	Right	Peds	Left	Thru	Right	Peds	Left	Thru	Right	Peds	Left	Thru	Right	Peds	
Grand Total	476	7105	954	3	105	1592	497	0	1264	7395	72	9	865	1734	1489	9	23569
Apprch %	5.6	83.2	11.2	0	4.8	72.6	22.7	0	14.5	84.6	0.8	0.1	21.1	42.3	36.3	0.2	
Total %	2	30.1	4	0	0.4	6.8	2.1	0	5.4	31.4	0.3	0	3.7	7.4	6.3	0	



MINNESOTA DEPT OF TRANSPORTATION

TRAFFIC DATA COLLECTION - METRO

MN-55 AT LONE OAK RD / CSAH-26
 REF.PT.: 202.512
 DATA COLLECTED BY TDI
 TURN MOVEMENT COUNT

File Name : TH-55 AT LONE OAK RD 2007
 Site Code : 00198722
 Start Date : 5/17/2007
 Page No : 3

Start Time	MN-55 Southbound					LONE OAK RD / CSAH-26 Westbound					MN-55 Northbound					LONE OAK RD / CSAH-26 Eastbound					Int. Total
	Left	Thru	Right	Peds	App. Total	Left	Thru	Right	Peds	App. Total	Left	Thru	Right	Peds	App. Total	Left	Thru	Right	Peds	App. Total	
Peak Hour Analysis From 06:00 to 08:45 - Peak 1 of 1																					
Peak Hour for Entire Intersection Begins at 07:15																					
07:15	7	216	34	0	257	1	37	30	0	68	52	364	4	0	420	23	75	39	0	137	882
07:30	5	193	33	0	231	0	58	21	0	79	59	352	1	1	413	33	76	39	0	148	871
07:45	13	237	39	0	289	5	60	24	0	89	83	369	5	0	457	46	85	38	0	169	1004
08:00	14	245	27	0	286	4	38	15	0	57	61	300	1	0	362	31	88	44	0	163	868
Total Volume	39	891	133	0	1063	10	193	90	0	293	255	1385	11	1	1652	133	324	160	0	617	3625
% App. Total	3.7	83.8	12.5	0		3.4	65.9	30.7	0		15.4	83.8	0.7	0.1		21.6	52.5	25.9	0		
PHF	.696	.909	.853	.000	.920	.500	.804	.750	.000	.823	.768	.938	.550	.250	.904	.723	.920	.909	.000	.913	.903

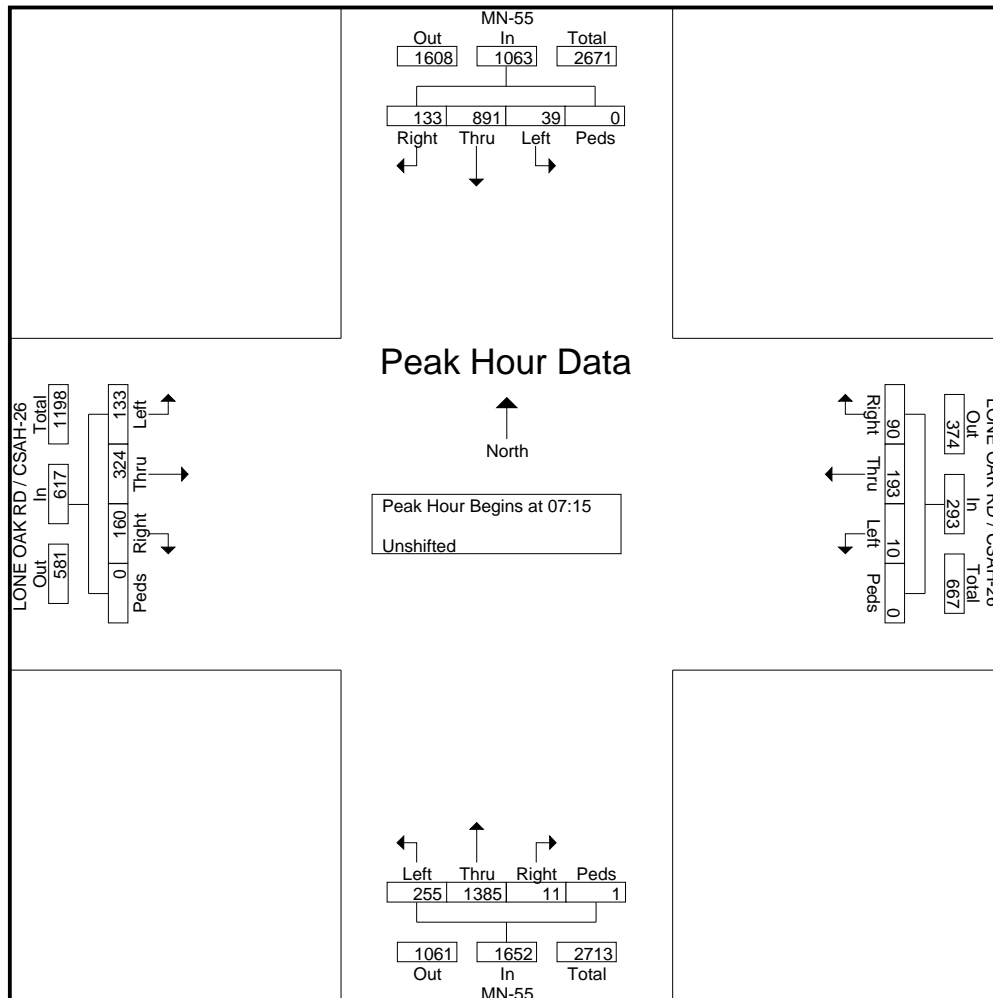



MINNESOTA DEPT OF TRANSPORTATION

TRAFFIC DATA COLLECTION - METRO

MN-55 AT LONE OAK RD / CSAH-26
 REF.PT.: 202.512
 DATA COLLECTED BY TDI
 TURN MOVEMENT COUNT

File Name : TH-55 AT LONE OAK RD 2007
 Site Code : 00198722
 Start Date : 5/17/2007
 Page No : 4

Start Time	MN-55 Southbound					LONE OAK RD / CSAH-26 Westbound					MN-55 Northbound					LONE OAK RD / CSAH-26 Eastbound					Int. Total
	Left	Thru	Right	Peds	App. Total	Left	Thru	Right	Peds	App. Total	Left	Thru	Right	Peds	App. Total	Left	Thru	Right	Peds	App. Total	
Peak Hour Analysis From 15:00 to 17:45 - Peak 1 of 1																					
Peak Hour for Entire Intersection Begins at 16:30																					
16:30	22	343	40	0	405	2	91	18	0	111	36	209	1	1	247	36	64	96	0	196	959
16:45	15	379	45	0	439	11	85	14	0	110	31	248	1	0	280	30	65	73	1	169	998
17:00	19	395	63	0	477	6	80	22	0	108	36	261	0	1	298	49	80	85	1	215	1098
17:15	15	358	63	0	436	7	81	10	0	98	36	246	0	1	283	21	66	66	0	153	970
Total Volume	71	1475	211	0	1757	26	337	64	0	427	139	964	2	3	1108	136	275	320	2	733	4025
% App. Total	4	83.9	12	0		6.1	78.9	15	0		12.5	87	0.2	0.3		18.6	37.5	43.7	0.3		
PHF	.807	.934	.837	.000	.921	.591	.926	.727	.000	.962	.965	.923	.500	.750	.930	.694	.859	.833	.500	.852	.916

