



# Minnesota Dept. of Transportation

## Traffic Data Collection -Metro

TH-65 / CENTRAL AVE AT 41ST AVE NE  
 Ref.Pt; 004.635  
 Jamar # T-2638 CAH  
 TURN MOVEMENT COUNT

File Name : TH-65 at 41st Ave NE 2012  
 Site Code : 004.635  
 Start Date : 3/8/2012  
 Page No : 1

**Groups Printed- Unshifted**

Start Time	TH-65 / CENTRAL AVE Southbound				41ST AVE NE Westbound				TH-65 / CENTRAL AVE Northbound				41ST AVE NE Eastbound				Int. Total
	Right	Thru	Left	Peds	Right	Thru	Left	Peds	Right	Thru	Left	Peds	Right	Thru	Left	Peds	
06:00	2	77	1	1	3	0	1	0	3	29	0	0	4	0	4	1	126
06:15	2	103	2	1	5	0	1	0	3	47	0	0	1	0	3	0	168
06:30	4	145	5	2	4	2	1	0	3	50	2	0	1	0	1	1	221
06:45	7	143	7	5	2	0	2	0	1	50	1	0	4	0	3	2	227
Total	15	468	15	9	14	2	5	0	10	176	3	0	10	0	11	4	742
07:00	6	150	3	1	3	1	3	0	2	75	0	0	1	1	5	0	251
07:15	11	223	7	0	5	1	2	0	0	97	3	0	3	1	5	0	358
07:30	15	239	6	0	4	0	4	1	2	115	5	2	9	0	5	1	408
07:45	19	219	9	0	7	1	5	0	3	125	2	0	1	0	11	1	403
Total	51	831	25	1	19	3	14	1	7	412	10	2	14	2	26	2	1420
08:00	14	190	8	2	7	4	4	3	9	88	0	1	4	0	10	0	344
08:15	11	157	7	2	6	1	4	3	3	94	1	2	2	1	5	0	299
08:30	10	150	9	1	12	2	4	0	5	89	0	0	8	1	3	0	294
08:45	5	146	12	2	9	3	2	2	2	115	1	3	1	1	7	0	311
Total	40	643	36	7	34	10	14	8	19	386	2	6	15	3	25	0	1248
*** BREAK ***																	
11:00	6	120	10	1	5	1	2	0	4	136	2	0	6	0	5	0	298
11:15	3	134	9	1	5	0	3	0	2	131	4	2	2	1	6	0	303
11:30	9	145	11	0	5	0	4	3	4	148	3	7	3	1	9	0	352
11:45	9	182	19	1	7	1	1	0	4	141	6	0	4	1	4	1	381
Total	27	581	49	3	22	2	10	3	14	556	15	9	15	3	24	1	1334
12:00	8	153	10	2	10	1	6	2	3	182	3	2	3	0	8	1	394
12:15	3	160	11	3	10	0	5	2	4	149	5	2	2	0	9	2	367
12:30	6	151	9	1	13	2	2	2	3	149	3	5	1	1	7	1	356
12:45	6	134	12	1	10	1	3	1	1	164	5	0	4	0	6	0	348
Total	23	598	42	7	43	4	16	7	11	644	16	9	10	1	30	4	1465
*** BREAK ***																	
15:00	9	147	4	1	3	1	3	1	3	210	2	2	5	1	13	0	405
15:15	4	169	11	3	6	0	7	1	6	204	4	8	3	0	7	3	436
15:30	6	187	13	5	9	1	9	0	4	231	8	2	3	3	13	7	501
15:45	6	159	13	7	26	2	13	2	2	232	2	8	5	0	12	5	494
Total	25	662	41	16	44	4	32	4	15	877	16	20	16	4	45	15	1836
16:00	5	166	15	4	8	0	6	1	3	201	3	5	3	0	8	3	431
16:15	11	170	4	5	6	2	4	0	3	304	4	3	2	0	9	3	530
16:30	10	153	17	5	4	2	5	3	4	221	1	3	2	0	5	4	439
16:45	8	209	11	8	10	0	6	0	3	243	8	2	6	0	13	0	527
Total	34	698	47	22	28	4	21	4	13	969	16	13	13	0	35	10	1927
17:00	4	176	10	4	14	0	3	2	2	265	5	6	4	2	18	1	516
17:15	9	192	14	2	10	2	6	7	6	251	7	12	1	3	11	1	534
17:30	5	153	15	3	7	1	1	1	4	217	4	4	7	2	8	1	433
17:45	7	143	8	7	10	0	3	0	5	214	4	7	4	0	5	1	418
Total	25	664	47	16	41	3	13	10	17	947	20	29	16	7	42	4	1901
Grand Total	240	5145	302	81	245	32	125	37	106	4967	98	88	109	20	238	40	11873
Apprch %	4.2	89.2	5.2	1.4	55.8	7.3	28.5	8.4	2	94.4	1.9	1.7	26.8	4.9	58.5	9.8	
Total %	2	43.3	2.5	0.7	2.1	0.3	1.1	0.3	0.9	41.8	0.8	0.7	0.9	0.2	2	0.3	



# Minnesota Dept. of Transportation

## Traffic Data Collection -Metro

TH-65 / CENTRAL AVE AT 41ST AVE NE  
 Ref.Pt; 004.635  
 Jamar # T-2638 CAH  
 TURN MOVEMENT COUNT

File Name : TH-65 at 41st Ave NE 2012  
 Site Code : 004.635  
 Start Date : 3/8/2012  
 Page No : 2

Start Time	TH-65 / CENTRAL AVE Southbound					41ST AVE NE Westbound					TH-65 / CENTRAL AVE Northbound					41ST AVE NE Eastbound					Int. Total
	Right	Thru	Left	Peds	App. Total	Right	Thru	Left	Peds	App. Total	Right	Thru	Left	Peds	App. Total	Right	Thru	Left	Peds	App. Total	
Peak Hour Analysis From 06:00 to 08:45 - Peak 1 of 1																					
Peak Hour for Entire Intersection Begins at 07:15																					
07:15	11	223	7	0	241	5	1	2	0	8	0	97	3	0	100	3	1	5	0	9	358
07:30	15	<b>239</b>	6	0	<b>260</b>	4	0	4	1	9	2	115	5	2	124	<b>9</b>	0	5	<b>1</b>	<b>15</b>	<b>408</b>
07:45	<b>19</b>	219	<b>9</b>	0	247	<b>7</b>	1	<b>5</b>	0	13	3	<b>125</b>	2	0	<b>130</b>	1	0	<b>11</b>	1	13	403
08:00	14	190	8	2	214	7	<b>4</b>	4	<b>3</b>	<b>18</b>	<b>9</b>	88	0	1	98	4	0	10	0	14	344
Total Volume	59	871	30	2	962	23	6	15	4	48	14	425	10	3	452	17	1	31	2	51	1513
% App. Total	6.1	90.5	3.1	0.2		47.9	12.5	31.2	8.3		3.1	94	2.2	0.7		33.3	2	60.8	3.9		
PHF	.776	.911	.833	.250	.925	.821	.375	.750	.333	.667	.389	.850	.500	.375	.869	.472	.250	.705	.500	.850	.927

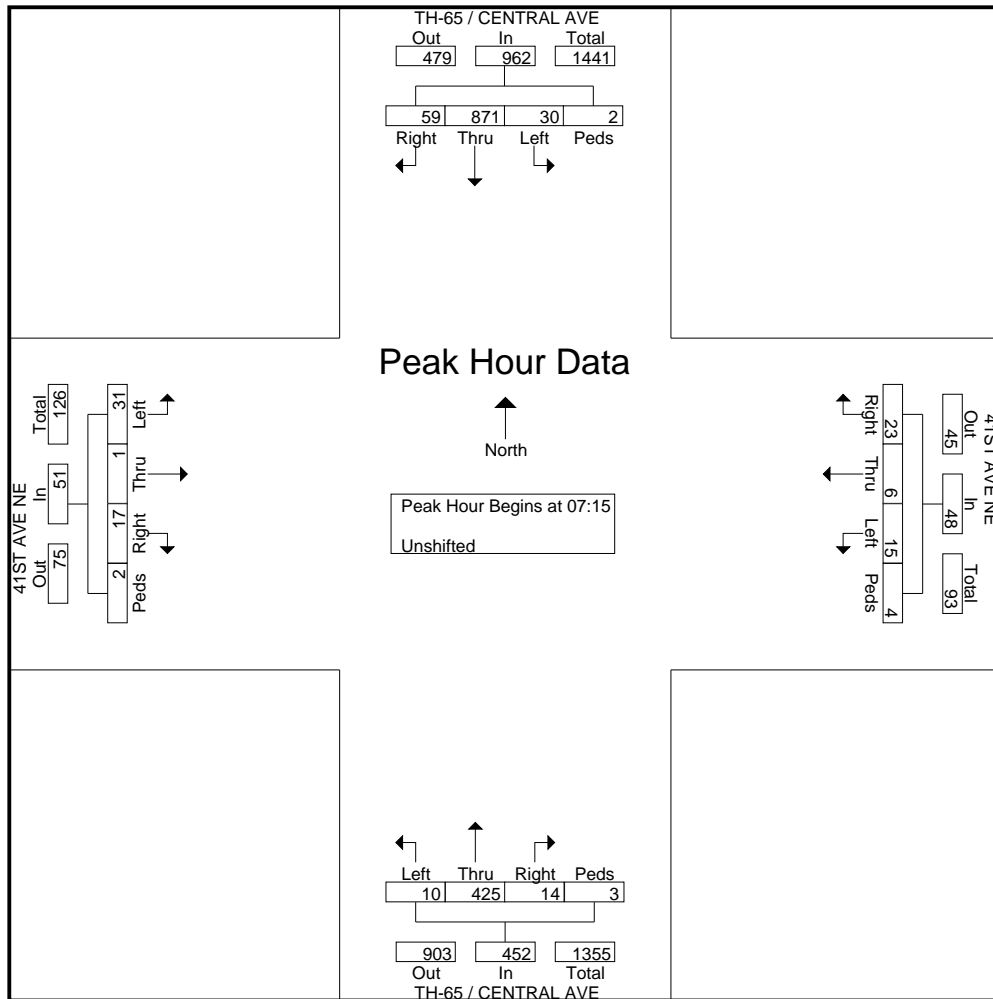



# Minnesota Dept. of Transportation

## Traffic Data Collection -Metro

TH-65 / CENTRAL AVE AT 41ST AVE NE  
 Ref.Pt; 004.635  
 Jamar # T-2638 CAH  
 TURN MOVEMENT COUNT

File Name : TH-65 at 41st Ave NE 2012  
 Site Code : 004.635  
 Start Date : 3/8/2012  
 Page No : 3

Start Time	TH-65 / CENTRAL AVE Southbound					41ST AVE NE Westbound					TH-65 / CENTRAL AVE Northbound					41ST AVE NE Eastbound					Int. Total
	Rig ht	Thr u	Left	Ped s	App. Total	Rig ht	Thr u	Left	Ped s	App. Total	Right	Thr u	Left	Peds	App. Total	Right	Thr u	Left	Peds	App. Total	
Peak Hour Analysis From 15:00 to 17:45 - Peak 1 of 1																					
Peak Hour for Entire Intersection Begins at 16:30																					
16:30	10	153	17	5	185	4	2	5	3	14	4	221	1	3	229	2	0	5	4	11	439
16:45	8	209	11	8	236	10	0	6	0	16	3	243	8	2	256	6	0	13	0	19	527
17:00	4	176	10	4	194	14	0	3	2	19	2	265	5	6	278	4	2	18	1	25	516
17:15	9	192	14	2	217	10	2	6	7	25	6	251	7	12	276	1	3	11	1	16	534
Total Volume	31	730	52	19	832	38	4	20	12	74	15	980	21	23	1039	13	5	47	6	71	2016
% App. Total	3.7	87.7	6.2	2.3		51.4	5.4	27	16.2		1.4	94.3	2	2.2		18.3	7	66.2	8.5		
PHF	.775	.873	.765	.594	.881	.679	.500	.833	.429	.740	.625	.925	.656	.479	.934	.542	.417	.653	.375	.710	.944

