



# MINNESOTA DEPT OF TRANSPORTATION

## TRAFFIC DATA COLLECTION - METRO

loc: th 65 @ 41st ave ne 2003  
 ref pt: 004+00.635  
 data collected by: alliant eng  
 tmc: am noon pm

File Name : T.H. 65 at 41st  
 Site Code : 00000002  
 Start Date : 7/29/2003  
 Page No : 1

**Groups Printed- Unshifted**

Start Time	T.H. 65 Southbound					41st Ave. NE Westbound					T.H. 65 Northbound					41st Ave. NE Eastbound					Int. Total
	Left	Thru	Right	Peds	App. Total	Left	Thru	Right	Peds	App. Total	Left	Thru	Right	Peds	App. Total	Left	Thru	Right	Peds	App. Total	
06:00	4	82	2	0	88	2	0	4	0	6	0	30	0	1	31	2	0	0	0	2	127
06:15	1	114	3	3	121	3	15	2	5	25	0	18	0	3	21	0	1	0	3	4	171
06:30	2	132	10	0	144	2	0	2	1	5	1	46	1	1	49	2	0	1	2	5	203
06:45	4	192	8	3	207	5	0	0	1	6	2	46	2	1	51	3	0	2	2	7	271
<b>Total</b>	<b>11</b>	<b>520</b>	<b>23</b>	<b>6</b>	<b>560</b>	<b>12</b>	<b>15</b>	<b>8</b>	<b>7</b>	<b>42</b>	<b>3</b>	<b>140</b>	<b>3</b>	<b>6</b>	<b>152</b>	<b>7</b>	<b>1</b>	<b>3</b>	<b>7</b>	<b>18</b>	<b>772</b>
07:00	8	185	13	5	211	4	0	3	3	10	5	50	1	0	56	4	1	0	0	5	282
07:15	4	192	16	1	213	1	1	6	3	11	11	69	0	1	81	2	1	1	2	6	311
07:30	4	223	6	0	233	2	0	5	2	9	9	75	0	0	84	4	0	3	0	7	333
07:45	4	186	5	3	198	6	1	7	1	15	2	98	0	3	103	4	0	1	5	10	326
<b>Total</b>	<b>20</b>	<b>786</b>	<b>40</b>	<b>9</b>	<b>855</b>	<b>13</b>	<b>2</b>	<b>21</b>	<b>9</b>	<b>45</b>	<b>27</b>	<b>292</b>	<b>1</b>	<b>4</b>	<b>324</b>	<b>14</b>	<b>2</b>	<b>5</b>	<b>7</b>	<b>28</b>	<b>1252</b>
08:00	5	151	7	5	168	4	0	3	8	15	0	66	0	1	67	7	0	1	0	8	258
08:15	5	146	4	1	156	1	0	4	1	6	1	97	1	1	100	4	0	0	0	4	266
08:30	5	154	3	5	167	4	0	11	1	16	3	93	2	0	98	5	0	2	5	12	293
08:45	3	138	6	1	148	3	15	4	2	24	6	81	1	0	88	0	0	3	0	3	263
<b>Total</b>	<b>18</b>	<b>589</b>	<b>20</b>	<b>12</b>	<b>639</b>	<b>12</b>	<b>15</b>	<b>22</b>	<b>12</b>	<b>61</b>	<b>10</b>	<b>337</b>	<b>4</b>	<b>2</b>	<b>353</b>	<b>16</b>	<b>0</b>	<b>6</b>	<b>5</b>	<b>27</b>	<b>1080</b>
11:00	22	176	4	1	203	7	0	14	5	26	10	145	5	2	162	10	0	10	0	20	411
11:15	18	147	6	2	173	11	0	9	2	22	5	147	3	1	156	3	0	2	2	7	358
11:30	17	163	3	0	183	4	2	13	6	25	6	176	7	5	194	11	1	10	2	24	426
11:45	9	150	6	2	167	3	0	14	0	17	3	166	5	2	176	9	2	2	3	16	376
<b>Total</b>	<b>66</b>	<b>636</b>	<b>19</b>	<b>5</b>	<b>726</b>	<b>25</b>	<b>2</b>	<b>50</b>	<b>13</b>	<b>90</b>	<b>24</b>	<b>634</b>	<b>20</b>	<b>10</b>	<b>688</b>	<b>33</b>	<b>3</b>	<b>24</b>	<b>7</b>	<b>67</b>	<b>1571</b>
12:00	13	175	10	7	205	5	0	9	1	15	5	188	4	0	197	14	0	6	1	21	438
12:15	15	175	4	1	195	5	0	12	2	19	4	173	1	0	178	14	11	3	0	28	420
12:30	12	186	10	0	208	2	0	11	3	16	4	191	4	2	201	16	0	8	0	24	449
12:45	14	194	1	2	211	2	0	8	3	13	4	186	3	5	198	16	2	21	4	43	465
<b>Total</b>	<b>54</b>	<b>730</b>	<b>25</b>	<b>10</b>	<b>819</b>	<b>14</b>	<b>0</b>	<b>40</b>	<b>9</b>	<b>63</b>	<b>17</b>	<b>738</b>	<b>12</b>	<b>7</b>	<b>774</b>	<b>60</b>	<b>13</b>	<b>38</b>	<b>5</b>	<b>116</b>	<b>1772</b>



# MINNESOTA DEPT OF TRANSPORTATION

## TRAFFIC DATA COLLECTION - METRO

File Name : T.H. 65 at 41st  
 Site Code : 00000002  
 Start Date : 7/29/2003  
 Page No : 2

**Groups Printed- Unshifted**

Start Time	T.H. 65 Southbound					41st Ave. NE Westbound					T.H. 65 Northbound					41st Ave. NE Eastbound					Int. Total
	Left	Thru	Right	Peds	App. Total	Left	Thru	Right	Peds	App. Total	Left	Thru	Right	Peds	App. Total	Left	Thru	Right	Peds	App. Total	
15:00	9	114	3	2	128	0	0	0	0	0	0	0	0	0	0	8	0	5	0	13	141
15:15	16	157	7	2	182	3	0	10	1	14	6	205	2	3	216	9	1	0	0	10	422
15:30	11	172	3	2	188	3	2	9	3	17	3	197	5	5	210	11	1	5	1	18	433
15:45	5	144	8	4	161	4	0	13	1	18	5	249	4	1	259	11	0	6	2	19	457
<b>Total</b>	<b>41</b>	<b>587</b>	<b>21</b>	<b>10</b>	<b>659</b>	<b>10</b>	<b>2</b>	<b>32</b>	<b>5</b>	<b>49</b>	<b>14</b>	<b>651</b>	<b>11</b>	<b>9</b>	<b>685</b>	<b>39</b>	<b>2</b>	<b>16</b>	<b>3</b>	<b>60</b>	<b>1453</b>
16:00	12	143	5	2	162	7	0	7	1	15	3	205	0	1	209	8	0	4	0	12	398
16:15	10	135	7	3	155	1	0	9	3	13	3	245	3	3	254	18	1	3	4	26	448
16:30	5	163	5	5	178	1	1	17	4	23	7	230	5	1	243	6	2	7	1	16	460
16:45	15	159	5	6	185	10	1	9	3	23	3	258	5	7	273	16	1	6	7	30	511
<b>Total</b>	<b>42</b>	<b>600</b>	<b>22</b>	<b>16</b>	<b>680</b>	<b>19</b>	<b>2</b>	<b>42</b>	<b>11</b>	<b>74</b>	<b>16</b>	<b>938</b>	<b>13</b>	<b>12</b>	<b>979</b>	<b>48</b>	<b>4</b>	<b>20</b>	<b>12</b>	<b>84</b>	<b>1817</b>
17:00	13	129	4	4	150	3	0	10	0	13	3	262	5	6	276	8	0	3	2	13	452
17:15	7	138	11	5	161	3	0	20	2	25	4	271	8	2	285	2	0	6	2	10	481
17:30	16	153	7	6	182	4	1	10	0	15	2	227	3	2	234	9	2	5	0	16	447
17:45	25	179	17	3	224	4	4	21	4	33	3	243	2	6	254	5	0	1	4	10	521
<b>Total</b>	<b>61</b>	<b>599</b>	<b>39</b>	<b>18</b>	<b>717</b>	<b>14</b>	<b>5</b>	<b>61</b>	<b>6</b>	<b>86</b>	<b>12</b>	<b>1003</b>	<b>18</b>	<b>16</b>	<b>1049</b>	<b>24</b>	<b>2</b>	<b>15</b>	<b>8</b>	<b>49</b>	<b>1901</b>
18:00	0	0	0	0	0	9	1	16	0	26	10	232	4	4	250	0	0	0	0	0	276
<b>Grand Total</b>	<b>313</b>	<b>5047</b>	<b>209</b>	<b>86</b>	<b>5655</b>	<b>128</b>	<b>44</b>	<b>292</b>	<b>72</b>	<b>536</b>	<b>133</b>	<b>4965</b>	<b>86</b>	<b>70</b>	<b>5254</b>	<b>241</b>	<b>27</b>	<b>127</b>	<b>54</b>	<b>449</b>	<b>11894</b>
<b>Apprch %</b>	<b>5.5</b>	<b>89.2</b>	<b>3.7</b>	<b>1.5</b>		<b>23.9</b>	<b>8.2</b>	<b>54.5</b>	<b>13.4</b>		<b>2.5</b>	<b>94.5</b>	<b>1.6</b>	<b>1.3</b>		<b>53.7</b>	<b>6</b>	<b>28.3</b>	<b>12</b>		
<b>Total %</b>	<b>2.6</b>	<b>42.4</b>	<b>1.8</b>	<b>0.7</b>	<b>47.5</b>	<b>1.1</b>	<b>0.4</b>	<b>2.5</b>	<b>0.6</b>	<b>4.5</b>	<b>1.1</b>	<b>41.7</b>	<b>0.7</b>	<b>0.6</b>	<b>44.2</b>	<b>2</b>	<b>0.2</b>	<b>1.1</b>	<b>0.5</b>	<b>3.8</b>	



# MINNESOTA DEPT OF TRANSPORTATION

## TRAFFIC DATA COLLECTION - METRO

File Name : T.H. 65 at 41st  
 Site Code : 00000002  
 Start Date : 7/29/2003  
 Page No : 3

Start Time	T.H. 65 Southbound					41st Ave. NE Westbound					T.H. 65 Northbound					41st Ave. NE Eastbound					Int. Total
	Left	Thru	Right	Peds	App. Total	Left	Thru	Right	Peds	App. Total	Left	Thru	Right	Peds	App. Total	Left	Thru	Right	Peds	App. Total	
Peak Hour Analysis From 06:00 to 09:45 - Peak 1 of 1																					
Peak Hour for Entire Intersection Begins at 07:00																					
07:00	8	185	13	5	211	4	0	3	3	10	5	50	1	0	56	4	1	0	0	5	282
07:15	4	192	16	1	213	1	1	6	3	11	11	69	0	1	81	2	1	1	2	6	311
07:30	4	223	6	0	233	2	0	5	2	9	9	75	0	0	84	4	0	3	0	7	333
07:45	4	186	5	3	198	6	1	7	1	15	2	98	0	3	103	4	0	1	5	10	326
Total Volume	20	786	40	9	855	13	2	21	9	45	27	292	1	4	324	14	2	5	7	28	1252
% App. Total	2.3	91.9	4.7	1.1		28.9	4.4	46.7	20		8.3	90.1	0.3	1.2		50	7.1	17.9	25		
PHF	.625	.881	.625	.450	.917	.542	.500	.750	.750	.750	.614	.745	.250	.333	.786	.875	.500	.417	.350	.700	.940

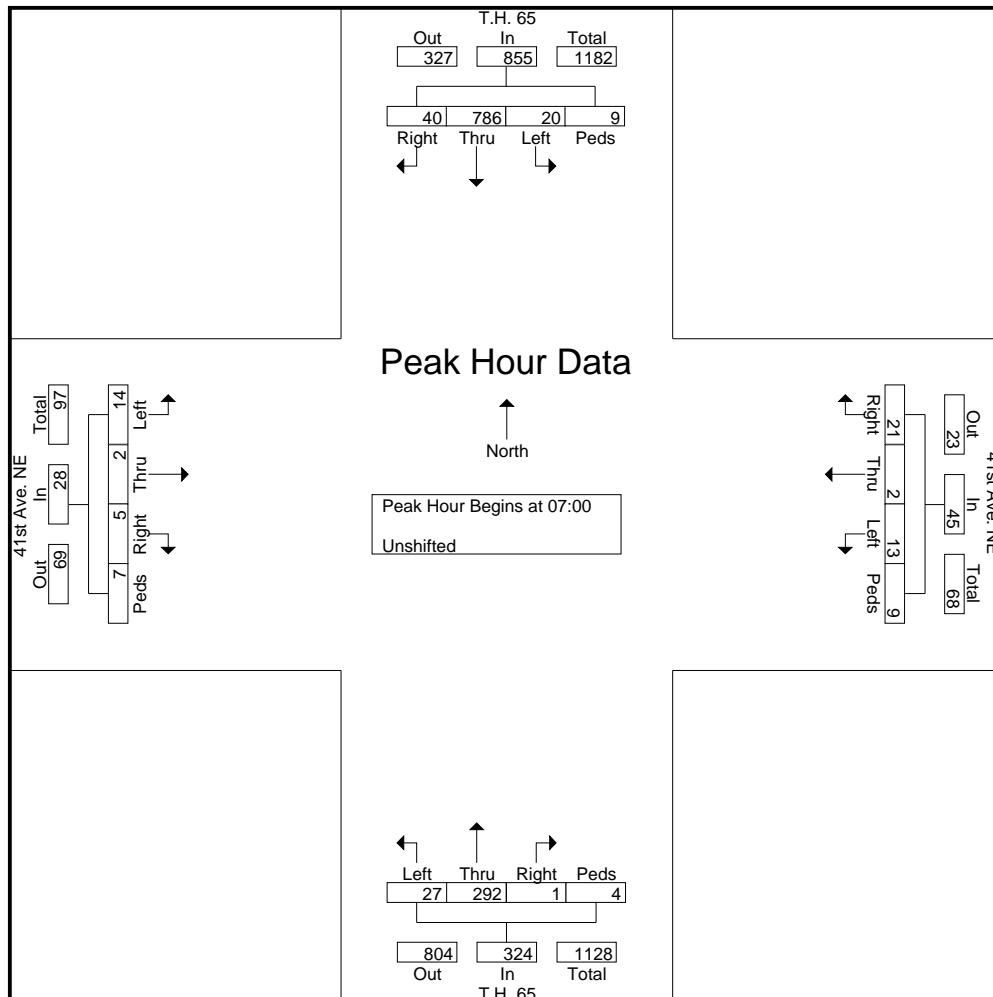



# MINNESOTA DEPT OF TRANSPORTATION

## TRAFFIC DATA COLLECTION - METRO

File Name : T.H. 65 at 41st  
 Site Code : 00000002  
 Start Date : 7/29/2003  
 Page No : 4

Start Time	T.H. 65 Southbound					41st Ave. NE Westbound					T.H. 65 Northbound					41st Ave. NE Eastbound					Int. Total
	Left	Thru	Right	Peds	App. Total	Left	Thru	Right	Peds	App. Total	Left	Thru	Right	Peds	App. Total	Left	Thru	Right	Peds	App. Total	
Peak Hour Analysis From 10:00 to 13:45 - Peak 1 of 1																					
Peak Hour for Entire Intersection Begins at 12:00																					
12:00	13	175	10	7	205	5	0	9	1	15	5	188	4	0	197	14	0	6	1	21	438
12:15	15	175	4	1	195	5	0	12	2	19	4	173	1	0	178	14	11	3	0	28	420
12:30	12	186	10	0	208	2	0	11	3	16	4	191	4	2	201	16	0	8	0	24	449
12:45	14	194	1	2	211	2	0	8	3	13	4	186	3	5	198	16	2	21	4	43	465
Total Volume	54	730	25	10	819	14	0	40	9	63	17	738	12	7	774	60	13	38	5	116	1772
% App. Total	6.6	89.1	3.1	1.2		22.2	0	63.5	14.3		2.2	95.3	1.6	0.9		51.7	11.2	32.8	4.3		
PHF	.900	.941	.625	.357	.970	.700	.000	.833	.750	.829	.850	.966	.750	.350	.963	.938	.295	.452	.313	.674	.953

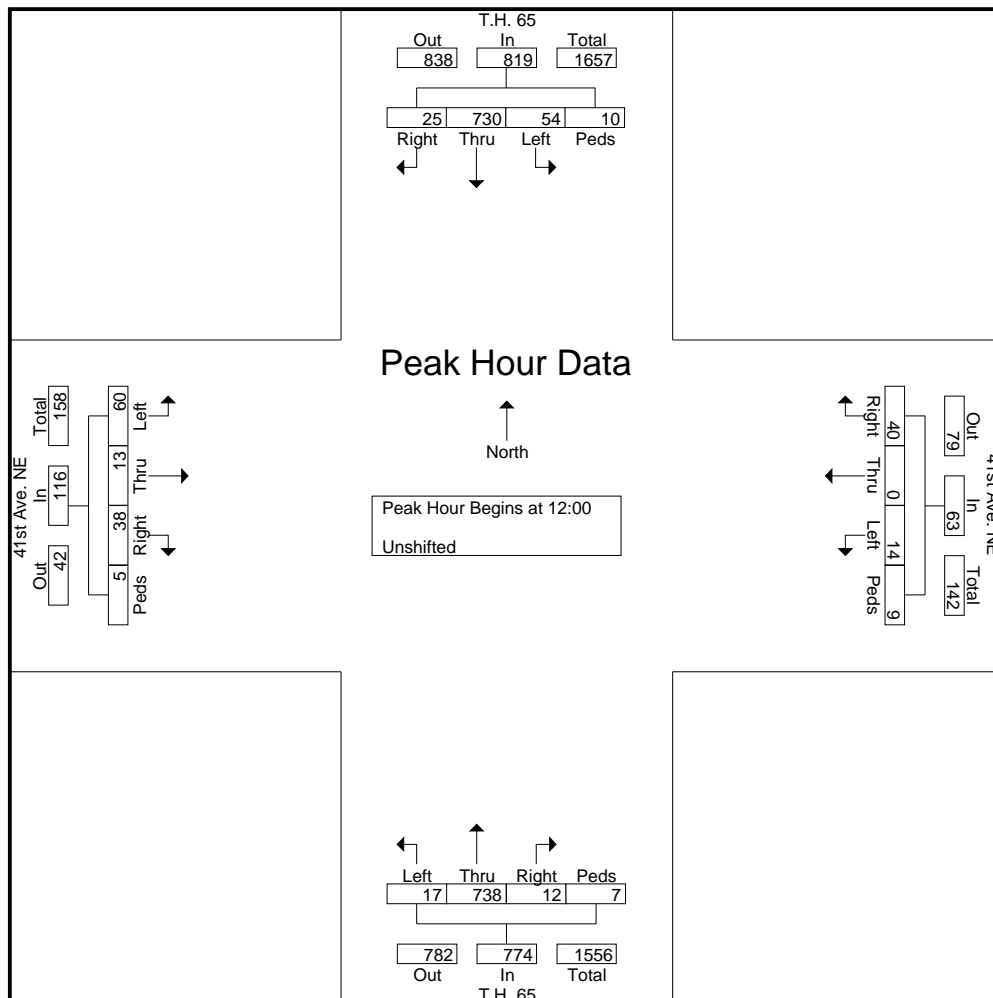



# MINNESOTA DEPT OF TRANSPORTATION

## TRAFFIC DATA COLLECTION - METRO

File Name : T.H. 65 at 41st  
 Site Code : 00000002  
 Start Date : 7/29/2003  
 Page No : 5

Start Time	T.H. 65 Southbound					41st Ave. NE Westbound					T.H. 65 Northbound					41st Ave. NE Eastbound					Int. Total
	Left	Thru	Right	Peds	App. Total	Left	Thru	Right	Peds	App. Total	Left	Thru	Right	Peds	App. Total	Left	Thru	Right	Peds	App. Total	
Peak Hour Analysis From 14:00 to 18:00 - Peak 1 of 1																					
Peak Hour for Entire Intersection Begins at 16:30																					
16:30	5	163	5	5	178	1	1	17	4	23	7	230	5	1	243	6	2	7	1	16	460
16:45	15	159	5	6	185	10	1	9	3	23	3	258	5	7	273	16	1	6	7	30	511
17:00	13	129	4	4	150	3	0	10	0	13	3	262	5	6	276	8	0	3	2	13	452
17:15	7	138	11	5	161	3	0	20	2	25	4	271	8	2	285	2	0	6	2	10	481
Total Volume	40	589	25	20	674	17	2	56	9	84	17	1021	23	16	1077	32	3	22	12	69	1904
% App. Total	5.9	87.4	3.7	3		20.2	2.4	66.7	10.7		1.6	94.8	2.1	1.5		46.4	4.3	31.9	17.4		
PHF	.667	.903	.568	.833	.911	.425	.500	.700	.563	.840	.607	.942	.719	.571	.945	.500	.375	.786	.429	.575	.932

