

**LOCATION:** TH 65 -- US 10 EB Ramps  
**CITY/STATE:** Blaine, MN

**QC JOB #:** 16374001  
**DATE:** Thu, Nov 9 2023

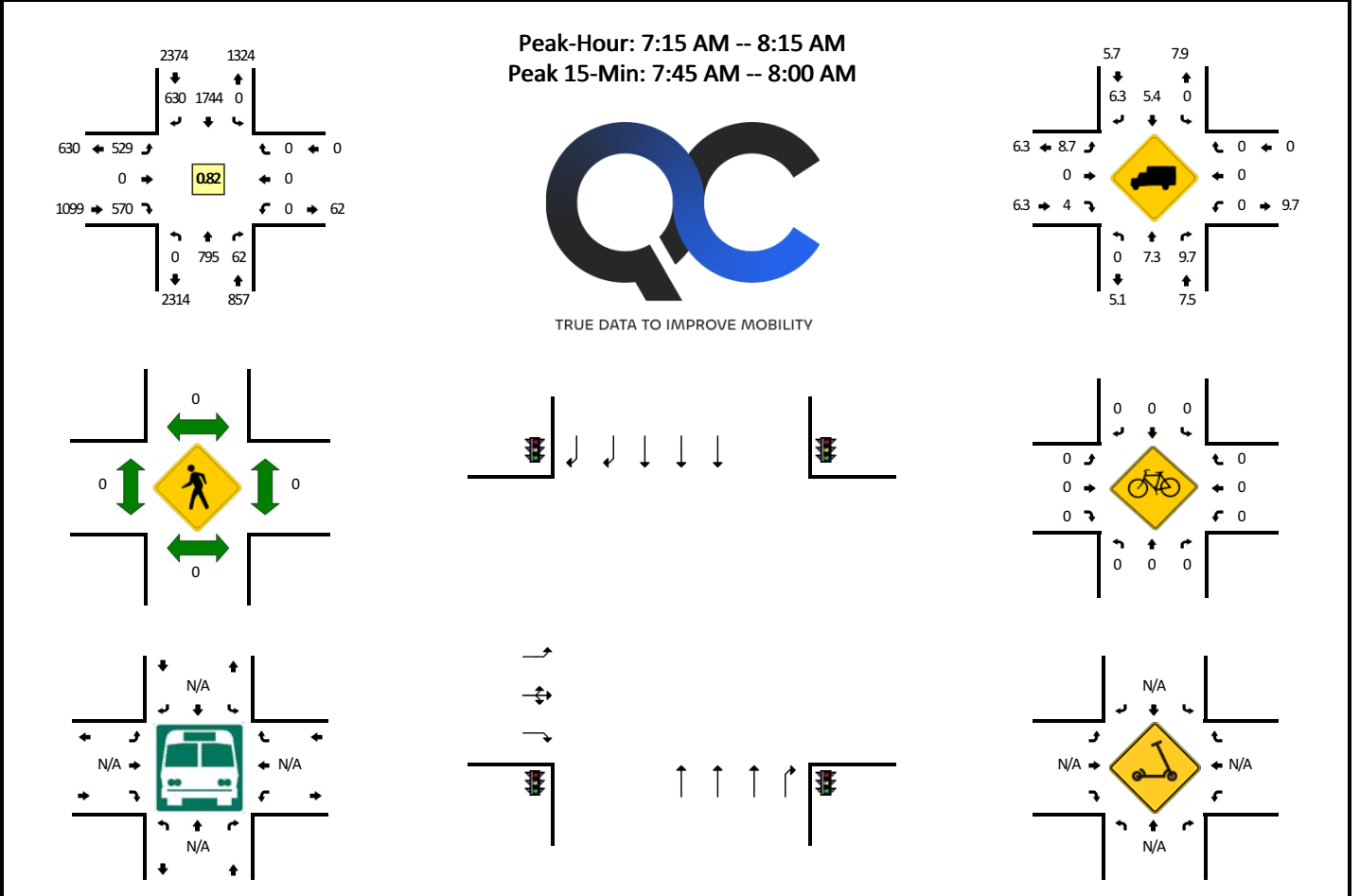

| 15-Min Count Period Beginning At | TH 65 (Northbound) |      |       |   | TH 65 (Southbound) |      |       |   | US 10 EB Ramps (Eastbound) |      |       |   | US 10 EB Ramps (Westbound) |      |       |   | Total | Hourly Totals |
|----------------------------------|--------------------|------|-------|---|--------------------|------|-------|---|----------------------------|------|-------|---|----------------------------|------|-------|---|-------|---------------|
|                                  | Left               | Thru | Right | U | Left               | Thru | Right | U | Left                       | Thru | Right | U | Left                       | Thru | Right | U |       |               |
| 7:00 AM                          | 0                  | 152  | 18    | 0 | 0                  | 354  | 182   | 0 | 74                         | 0    | 84    | 0 | 0                          | 0    | 0     | 0 | 864   |               |
| 7:15 AM                          | 0                  | 146  | 13    | 0 | 0                  | 401  | 189   | 0 | 133                        | 0    | 109   | 0 | 0                          | 0    | 0     | 0 | 991   |               |
| 7:30 AM                          | 0                  | 186  | 12    | 0 | 0                  | 515  | 156   | 0 | 90                         | 0    | 121   | 0 | 0                          | 0    | 0     | 0 | 1080  |               |
| 7:45 AM                          | 0                  | 264  | 19    | 0 | 0                  | 554  | 126   | 0 | 166                        | 0    | 188   | 0 | 0                          | 0    | 0     | 0 | 1317  | 4252          |
| 8:00 AM                          | 0                  | 199  | 18    | 0 | 0                  | 274  | 159   | 0 | 140                        | 0    | 152   | 0 | 0                          | 0    | 0     | 0 | 942   | 4330          |
| 8:15 AM                          | 0                  | 210  | 14    | 0 | 0                  | 302  | 173   | 0 | 110                        | 0    | 96    | 0 | 0                          | 0    | 0     | 0 | 905   | 4244          |
| 8:30 AM                          | 0                  | 151  | 16    | 0 | 0                  | 277  | 188   | 0 | 111                        | 1    | 79    | 0 | 0                          | 0    | 0     | 0 | 823   | 3987          |
| 8:45 AM                          | 0                  | 206  | 30    | 0 | 0                  | 271  | 148   | 0 | 113                        | 1    | 98    | 0 | 0                          | 0    | 0     | 0 | 867   | 3537          |
| Peak 15-Min Flowrates            | Northbound         |      |       |   | Southbound         |      |       |   | Eastbound                  |      |       |   | Westbound                  |      |       |   | Total |               |
|                                  | Left               | Thru | Right | U | Left               | Thru | Right | U | Left                       | Thru | Right | U | Left                       | Thru | Right | U |       |               |
| All Vehicles                     | 0                  | 1056 | 76    | 0 | 0                  | 2216 | 504   | 0 | 664                        | 0    | 752   | 0 | 0                          | 0    | 0     | 0 | 5268  |               |
| Heavy Trucks                     | 0                  | 72   | 8     |   | 0                  | 124  | 32    |   | 68                         | 0    | 12    |   | 0                          | 0    | 0     |   | 316   |               |
| Buses                            |                    |      |       |   |                    |      |       |   |                            |      |       |   |                            |      |       |   | 0     |               |
| Pedestrians                      |                    | 0    |       |   |                    | 0    |       |   |                            | 0    |       |   |                            | 0    |       |   | 0     |               |
| Bicycles                         | 0                  | 0    | 0     |   | 0                  | 0    | 0     |   | 0                          | 0    | 0     |   | 0                          | 0    | 0     |   | 0     |               |
| Scoters                          |                    |      |       |   |                    |      |       |   |                            |      |       |   |                            |      |       |   | 0     |               |

Comments: