



MINNESOTA DEPT OF TRANSPORTATION

TRAFFIC DATA COLLECTION - METRO

loc: th 65 @ 99th ave ne 2003
 ref pt: 012+00.164
 data collected by: alliant eng
 tmc: am noon pm

File Name : T.H. 65 at 99th
 Site Code : 00000023
 Start Date : 8/21/2003
 Page No : 1

Groups Printed- Unshifted

Start Time	T.H. 65 Southbound					99th Ave. NE Westbound					T.H. 65 Northbound					99th Ave. NE Eastbound					Int. Total
	Left	Thru	Right	Peds	App. Total	Left	Thru	Right	Peds	App. Total	Left	Thru	Right	Peds	App. Total	Left	Thru	Right	Peds	App. Total	
06:00	1	551	10	0	562	4	2	0	0	6	9	127	3	0	139	11	6	17	0	34	741
06:15	0	611	10	0	621	9	9	0	0	18	11	178	14	0	203	13	14	17	0	44	886
06:30	1	706	7	0	714	9	5	10	1	25	4	216	13	0	233	24	15	21	1	61	1033
06:45	5	636	16	0	657	18	4	1	0	23	6	242	23	0	271	25	21	26	0	72	1023
Total	7	2504	43	0	2554	40	20	11	1	72	30	763	53	0	846	73	56	81	1	211	3683
07:00	2	643	22	0	667	24	5	1	0	30	8	222	13	0	243	24	8	26	0	58	998
07:15	4	631	18	0	653	18	12	1	0	31	8	215	11	0	234	20	6	19	0	45	963
07:30	2	619	23	0	644	27	8	2	0	37	7	241	13	0	261	25	23	22	0	70	1012
07:45	1	648	19	0	668	9	5	4	1	19	12	245	6	0	263	21	22	24	0	67	1017
Total	9	2541	82	0	2632	78	30	8	1	117	35	923	43	0	1001	90	59	91	0	240	3990
08:00	5	575	18	0	598	9	7	0	0	16	3	183	8	0	194	20	10	27	1	58	866
08:15	2	487	23	0	512	12	6	1	0	19	8	228	13	0	249	20	7	15	0	42	822
08:30	4	467	17	0	488	13	4	2	0	19	10	208	8	0	226	21	6	18	0	45	778
08:45	2	356	20	0	378	6	4	1	0	11	9	230	8	0	247	16	13	20	0	49	685
Total	13	1885	78	0	1976	40	21	4	0	65	30	849	37	0	916	77	36	80	1	194	3151
11:00	2	305	21	0	328	15	9	12	0	36	10	234	83	0	327	28	5	19	1	53	744
11:15	1	328	27	0	356	15	8	7	0	30	13	314	41	0	368	23	8	9	0	40	794
11:30	2	404	31	0	437	17	12	10	0	39	19	318	17	0	354	22	8	10	0	40	870
11:45	4	356	27	0	387	21	15	13	0	49	10	309	13	0	332	24	10	13	0	47	815
Total	9	1393	106	0	1508	68	44	42	0	154	52	1175	154	0	1381	97	31	51	1	180	3223
12:00	3	305	30	0	338	20	23	9	1	53	14	325	15	0	354	26	7	5	0	38	783
12:15	7	331	30	0	368	10	4	10	0	24	17	374	16	0	407	15	12	7	0	34	833
12:30	5	378	25	0	408	29	11	8	0	48	14	321	13	0	348	33	6	13	0	52	856
12:45	4	323	20	0	347	13	7	6	0	26	14	360	22	0	396	32	8	8	0	48	817
Total	19	1337	105	0	1461	72	45	33	1	151	59	1380	66	0	1505	106	33	33	0	172	3289



MINNESOTA DEPT OF TRANSPORTATION

TRAFFIC DATA COLLECTION - METRO

File Name : T.H. 65 at 99th
 Site Code : 00000023
 Start Date : 8/21/2003
 Page No : 2

Groups Printed- Unshifted

Start Time	T.H. 65 Southbound					99th Ave. NE Westbound					T.H. 65 Northbound					99th Ave. NE Eastbound					Int. Total
	Left	Thru	Right	Peds	App. Total	Left	Thru	Right	Peds	App. Total	Left	Thru	Right	Peds	App. Total	Left	Thru	Right	Peds	App. Total	
15:00	4	295	19	0	318	24	12	17	0	53	18	558	8	0	584	38	16	13	1	68	1023
15:15	2	317	29	0	348	19	14	12	0	45	10	516	11	0	537	32	11	13	0	56	986
15:30	6	414	37	0	457	27	21	23	0	71	17	533	14	0	564	24	44	16	0	84	1176
15:45	2	316	29	0	347	18	17	14	0	49	19	577	11	0	607	24	10	16	0	50	1053
Total	14	1342	114	0	1470	88	64	66	0	218	64	2184	44	0	2292	118	81	58	1	258	4238
16:00	2	355	24	0	381	26	23	17	1	67	14	509	8	0	531	38	6	6	0	50	1029
16:15	2	312	31	0	345	36	30	12	0	78	16	596	11	0	623	24	15	10	0	49	1095
16:30	0	369	40	1	410	26	28	22	0	76	15	613	15	0	643	26	11	15	0	52	1181
16:45	6	310	40	0	356	23	20	9	1	53	17	578	14	0	609	35	20	15	0	70	1088
Total	10	1346	135	1	1492	111	101	60	2	274	62	2296	48	0	2406	123	52	46	0	221	4393
17:00	1	363	27	0	391	22	25	7	0	54	24	589	22	0	635	38	17	12	0	67	1147
17:15	5	233	18	0	256	5	21	10	0	36	19	576	20	0	615	31	11	10	0	52	959
17:30	2	341	28	0	371	12	14	15	0	41	13	582	23	0	618	29	20	20	0	69	1099
17:45	4	335	28	0	367	11	11	5	0	27	0	0	0	0	0	0	0	0	0	0	394
Total	12	1272	101	0	1385	50	71	37	0	158	56	1747	65	0	1868	98	48	42	0	188	3599
Grand Total	93	13620	764	1	14478	547	396	261	5	1209	388	11317	510	0	12215	782	396	482	4	1664	29566
Apprch %	0.6	94.1	5.3	0		45.2	32.8	21.6	0.4		3.2	92.6	4.2	0		47	23.8	29	0.2		
Total %	0.3	46.1	2.6	0	49	1.9	1.3	0.9	0	4.1	1.3	38.3	1.7	0	41.3	2.6	1.3	1.6	0	5.6	



MINNESOTA DEPT OF TRANSPORTATION

TRAFFIC DATA COLLECTION - METRO

File Name : T.H. 65 at 99th
 Site Code : 00000023
 Start Date : 8/21/2003
 Page No : 3

Start Time	T.H. 65 Southbound					99th Ave. NE Westbound					T.H. 65 Northbound					99th Ave. NE Eastbound					Int. Total
	Left	Thru	Right	Peds	App. Total	Left	Thru	Right	Peds	App. Total	Left	Thru	Right	Peds	App. Total	Left	Thru	Right	Peds	App. Total	
Peak Hour Analysis From 06:00 to 09:45 - Peak 1 of 1																					
Peak Hour for Entire Intersection Begins at 06:30																					
06:30	1	706	7	0	714	9	5	10	1	25	4	216	13	0	233	24	15	21	1	61	1033
06:45	5	636	16	0	657	18	4	1	0	23	6	242	23	0	271	25	21	26	0	72	1023
07:00	2	643	22	0	667	24	5	1	0	30	8	222	13	0	243	24	8	26	0	58	998
07:15	4	631	18	0	653	18	12	1	0	31	8	215	11	0	234	20	6	19	0	45	963
Total Volume	12	2616	63	0	2691	69	26	13	1	109	26	895	60	0	981	93	50	92	1	236	4017
% App. Total	0.4	97.2	2.3	0		63.3	23.9	11.9	0.9		2.7	91.2	6.1	0		39.4	21.2	39	0.4		
PHF	.600	.926	.716	.000	.942	.719	.542	.325	.250	.879	.813	.925	.652	.000	.905	.930	.595	.885	.250	.819	.972

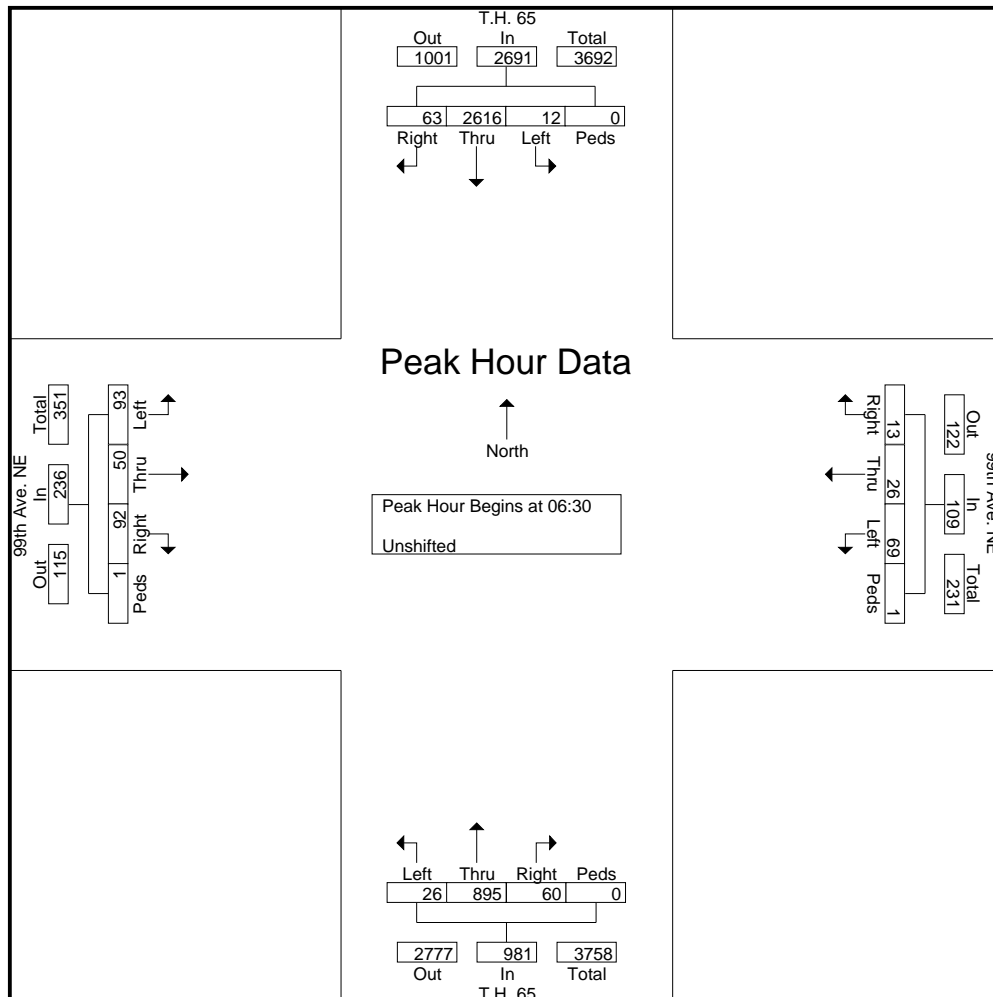



MINNESOTA DEPT OF TRANSPORTATION

TRAFFIC DATA COLLECTION - METRO

File Name : T.H. 65 at 99th
 Site Code : 00000023
 Start Date : 8/21/2003
 Page No : 4

Start Time	T.H. 65 Southbound					99th Ave. NE Westbound					T.H. 65 Northbound					99th Ave. NE Eastbound					Int. Total
	Left	Thru	Right	Peds	App. Total	Left	Thru	Right	Peds	App. Total	Left	Thru	Right	Peds	App. Total	Left	Thru	Right	Peds	App. Total	
Peak Hour Analysis From 10:00 to 13:45 - Peak 1 of 1																					
Peak Hour for Entire Intersection Begins at 11:30																					
11:30	2	404	31	0	437	17	12	10	0	39	19	318	17	0	354	22	8	10	0	40	870
11:45	4	356	27	0	387	21	15	13	0	49	10	309	13	0	332	24	10	13	0	47	815
12:00	3	305	30	0	338	20	23	9	1	53	14	325	15	0	354	26	7	5	0	38	783
12:15	7	331	30	0	368	10	4	10	0	24	17	374	16	0	407	15	12	7	0	34	833
Total Volume	16	1396	118	0	1530	68	54	42	1	165	60	1326	61	0	1447	87	37	35	0	159	3301
% App. Total	1	91.2	7.7	0		41.2	32.7	25.5	0.6		4.1	91.6	4.2	0		54.7	23.3	22	0		
PHF	.571	.864	.952	.000	.875	.810	.587	.808	.250	.778	.789	.886	.897	.000	.889	.837	.771	.673	.000	.846	.949

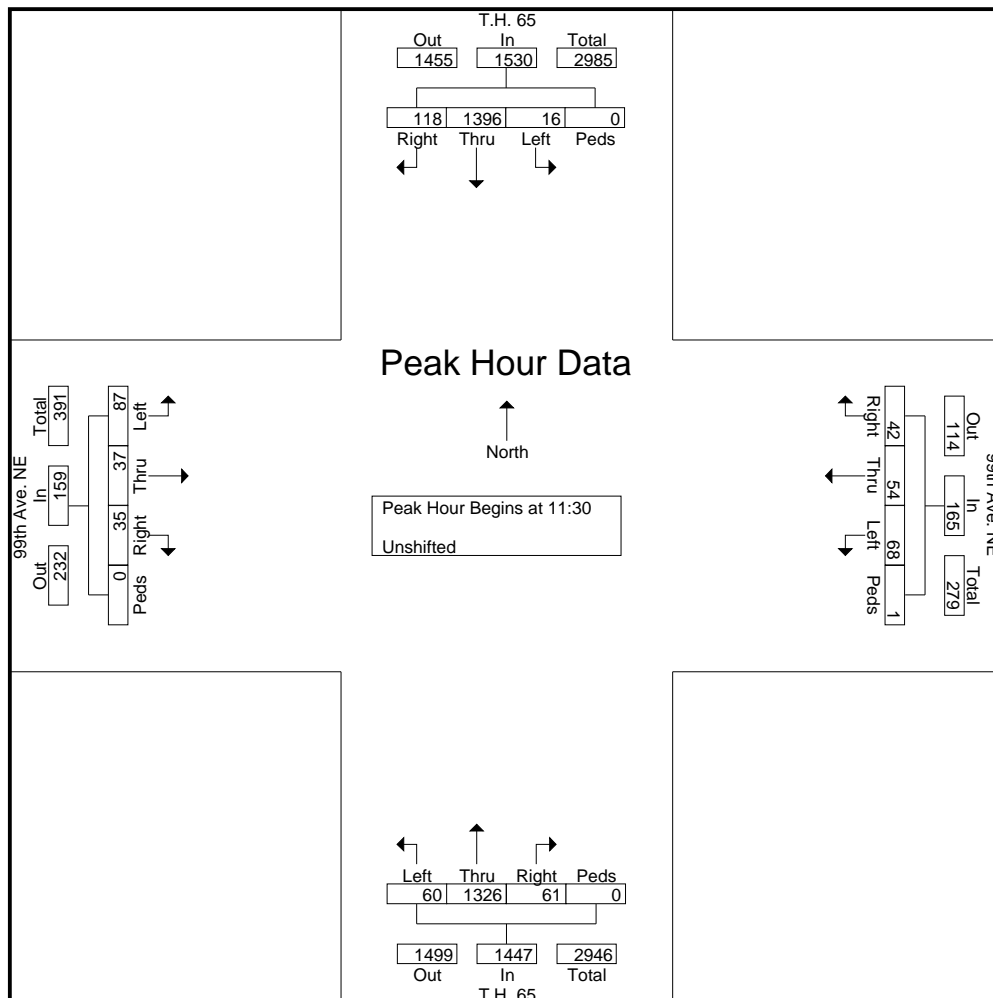



MINNESOTA DEPT OF TRANSPORTATION

TRAFFIC DATA COLLECTION - METRO

File Name : T.H. 65 at 99th
 Site Code : 00000023
 Start Date : 8/21/2003
 Page No : 5

Start Time	T.H. 65 Southbound					99th Ave. NE Westbound					T.H. 65 Northbound					99th Ave. NE Eastbound					Int. Total
	Left	Thru	Right	Peds	App. Total	Left	Thru	Right	Peds	App. Total	Left	Thru	Right	Peds	App. Total	Left	Thru	Right	Peds	App. Total	
Peak Hour Analysis From 14:00 to 17:45 - Peak 1 of 1																					
Peak Hour for Entire Intersection Begins at 16:15																					
16:15	2	312	31	0	345	36	30	12	0	78	16	596	11	0	623	24	15	10	0	49	1095
16:30	0	369	40	1	410	26	28	22	0	76	15	613	15	0	643	26	11	15	0	52	1181
16:45	6	310	40	0	356	23	20	9	1	53	17	578	14	0	609	35	20	15	0	70	1088
17:00	1	363	27	0	391	22	25	7	0	54	24	589	22	0	635	38	17	12	0	67	1147
Total Volume	9	1354	138	1	1502	107	103	50	1	261	72	2376	62	0	2510	123	63	52	0	238	4511
% App. Total	0.6	90.1	9.2	0.1		41	39.5	19.2	0.4		2.9	94.7	2.5	0		51.7	26.5	21.8	0		
PHF	.375	.917	.863	.250	.916	.743	.858	.568	.250	.837	.750	.969	.705	.000	.976	.809	.788	.867	.000	.850	.955

