

Alliant Engineering Inc Minneapolis, MN 55415

TH-65 at Viking Blvd NE / CSAH-22
 Ref.Pt.: 023.872 EAST BETHEL
 data by Alliant Engineering Inc
 TURN MOVEMENT COUNT

File Name : TH-65 at Viking Blvd NE CSAH-22 2009
 Site Code : 00000022
 Start Date : 1/20/2009
 Page No : 1

Groups Printed- Unshifted

Start Time	TH-65 Southbound				Viking Blvd NE / CSAH-22 Westbound				TH-65 Northbound				Viking Blvd NE / CSAH-22 Eastbound				Int. Total
	Left	Thru	Right	Peds	Left	Thru	Right	Peds	Left	Thru	Right	Peds	Left	Thru	Right	Peds	
06:00	1	370	9	0	43	19	5	0	4	31	2	0	2	9	33	0	528
06:15	5	400	24	0	27	24	5	0	6	39	5	0	4	13	36	0	588
06:30	5	356	13	0	39	14	8	0	4	56	0	0	4	13	26	0	538
06:45	3	343	14	0	57	23	9	0	6	70	4	0	5	9	52	0	595
Total	14	1469	60	0	166	80	27	0	20	196	11	0	15	44	147	0	2249
07:00	5	325	14	2	56	15	1	0	7	66	2	0	3	8	48	0	552
07:15	6	307	16	0	58	27	3	0	9	62	3	0	8	16	26	0	541
07:30	6	334	16	0	33	13	6	0	10	113	9	0	10	20	36	0	606
07:45	5	264	10	0	38	15	8	0	9	74	4	0	7	16	32	0	482
Total	22	1230	56	2	185	70	18	0	35	315	18	0	28	60	142	0	2181
08:00	7	208	6	0	30	6	7	0	11	70	4	0	3	9	32	0	393
08:15	6	208	8	0	29	16	7	0	4	79	13	0	4	11	26	0	411
08:30	5	203	14	0	33	16	7	0	6	67	1	0	9	10	21	0	392
08:45	2	167	4	0	23	12	16	0	4	66	4	0	5	11	19	0	333
Total	20	786	32	0	115	50	37	0	25	282	22	0	21	41	98	0	1529
09:00	11	165	8	0	32	10	13	0	8	68	9	0	2	5	6	0	337
09:15	8	159	7	0	18	14	6	0	10	77	11	0	5	15	16	0	346
*** BREAK ***																	
Total	19	324	15	0	50	24	19	0	18	145	20	0	7	20	22	0	683
*** BREAK ***																	
10:30	3	83	8	0	20	6	6	0	7	74	9	0	17	7	12	0	252
10:45	11	110	5	0	8	8	9	0	12	70	14	0	5	3	7	0	262
Total	14	193	13	0	28	14	15	0	19	144	23	0	22	10	19	0	514
11:00	2	95	5	0	10	5	0	0	16	70	18	0	6	5	9	0	241
11:15	0	97	8	0	17	8	3	0	15	93	9	0	8	5	12	0	275
11:30	5	105	1	0	13	7	6	0	21	81	6	0	5	6	5	0	261
11:45	2	120	4	0	21	9	6	0	14	87	15	0	5	8	9	0	300
Total	9	417	18	0	61	29	15	0	66	331	48	0	24	24	35	0	1077
12:00	4	108	4	0	11	4	3	0	15	96	17	0	11	7	10	0	290
12:15	1	117	20	0	14	14	8	0	12	96	11	0	6	9	12	0	320
12:30	4	117	6	0	6	6	8	0	10	120	17	0	8	9	17	0	328
12:45	5	134	8	0	16	4	2	0	12	115	23	0	5	3	10	0	337
Total	14	476	38	0	47	28	21	0	49	427	68	0	30	28	49	0	1275
13:00	4	102	6	0	16	3	8	0	15	101	10	0	7	12	11	0	295
13:15	3	86	5	0	18	8	4	0	14	123	21	0	6	11	7	0	306
*** BREAK ***																	
Total	7	188	11	0	34	11	12	0	29	224	31	0	13	23	18	0	601
*** BREAK ***																	
14:30	4	109	9	0	14	8	6	0	22	188	28	0	15	11	5	0	419
14:45	16	92	12	0	16	8	6	0	18	211	28	0	10	6	6	0	429
Total	20	201	21	0	30	16	12	0	40	399	56	0	25	17	11	0	848
15:00	7	93	8	0	13	11	6	0	26	241	37	0	18	10	8	0	478
15:15	2	119	6	0	24	8	8	0	33	292	33	0	24	13	6	0	568
15:30	4	132	13	0	12	12	21	0	29	263	43	0	20	16	9	0	574
15:45	13	119	13	0	23	25	11	0	24	344	44	0	12	26	12	0	666
Total	26	463	40	0	72	56	46	0	112	1140	157	0	74	65	35	0	2286

Alliant Engineering Inc

Minneapolis, MN 55415

TH-65 at Viking Blvd NE / CSAH-22
 Ref.Pt.: 023.872 EAST BETHEL
 data by Alliant Engineering Inc
 TURN MOVEMENT COUNT

File Name : TH-65 at Viking Blvd NE CSAH-22 2009
 Site Code : 00000022
 Start Date : 1/20/2009
 Page No : 2

Groups Printed- Unshifted

Start Time	TH-65 Southbound				Viking Blvd NE / CSAH-22 Westbound				TH-65 Northbound				Viking Blvd NE / CSAH-22 Eastbound				Int. Total
	Left	Thru	Right	Peds	Left	Thru	Right	Peds	Left	Thru	Right	Peds	Left	Thru	Right	Peds	
16:00	18	133	5	0	18	12	16	0	27	294	58	0	33	18	11	0	643
16:15	2	129	17	0	24	15	14	0	33	395	37	0	26	22	22	0	736
16:30	14	127	12	0	11	16	15	0	33	391	39	0	22	23	22	0	725
16:45	12	116	17	0	21	25	18	0	46	366	41	0	20	30	13	0	725
Total	46	505	51	0	74	68	63	0	139	1446	175	0	101	93	68	0	2829
17:00	9	158	16	0	22	18	25	0	33	390	42	0	31	24	15	0	783
17:15	7	128	12	0	14	16	17	0	49	400	38	0	19	21	18	0	739
17:30	10	129	9	0	25	14	16	0	34	318	46	0	31	21	14	0	667
17:45	9	86	10	0	17	15	21	0	33	294	39	0	34	18	9	0	585
Total	35	501	47	0	78	63	79	0	149	1402	165	0	115	84	56	0	2774
Grand Total	246	6753	402	2	940	509	364	0	701	6451	794	0	475	509	700	0	18846
Apprch %	3.3	91.2	5.4	0	51.8	28.1	20.1	0	8.8	81.2	10	0	28.2	30.2	41.6	0	
Total %	1.3	35.8	2.1	0	5	2.7	1.9	0	3.7	34.2	4.2	0	2.5	2.7	3.7	0	

Alliant Engineering Inc Minneapolis, MN 55415

TH-65 at Viking Blvd NE / CSAH-22
 Ref.Pt.: 023.872 EAST BETHEL
 data by Alliant Engineering Inc
 TURN MOVEMENT COUNT

File Name : TH-65 at Viking Blvd NE CSAH-22 2009
 Site Code : 00000022
 Start Date : 1/20/2009
 Page No : 3

Start Time	TH-65 Southbound					Viking Blvd NE / CSAH-22 Westbound					TH-65 Northbound					Viking Blvd NE / CSAH-22 Eastbound					Int. Total
	Left	Thru	Right	Peds	App. Total	Left	Thru	Right	Peds	App. Total	Left	Thru	Right	Peds	App. Total	Left	Thru	Right	Peds	App. Total	
Peak Hour Analysis From 06:00 to 08:45 - Peak 1 of 1																					
Peak Hour for Entire Intersection Begins at 06:45																					
06:45	3	343	14	0	360	57	23	9	0	89	6	70	4	0	80	5	9	52	0	66	595
07:00	5	325	14	2	346	56	15	1	0	72	7	66	2	0	75	3	8	48	0	59	552
07:15	6	307	16	0	329	58	27	3	0	88	9	62	3	0	74	8	16	26	0	50	541
07:30	6	334	16	0	356	33	13	6	0	52	10	113	9	0	132	10	20	36	0	66	606
Total Volume	20	1309	60	2	1391	204	78	19	0	301	32	311	18	0	361	26	53	162	0	241	2294
% App. Total	1.4	94.1	4.3	0.1		67.8	25.9	6.3	0		8.9	86.1	5	0		10.8	22	67.2	0		
PHF	.833	.954	.938	.250	.966	.879	.722	.528	.000	.846	.800	.688	.500	.000	.684	.650	.663	.779	.000	.913	.946

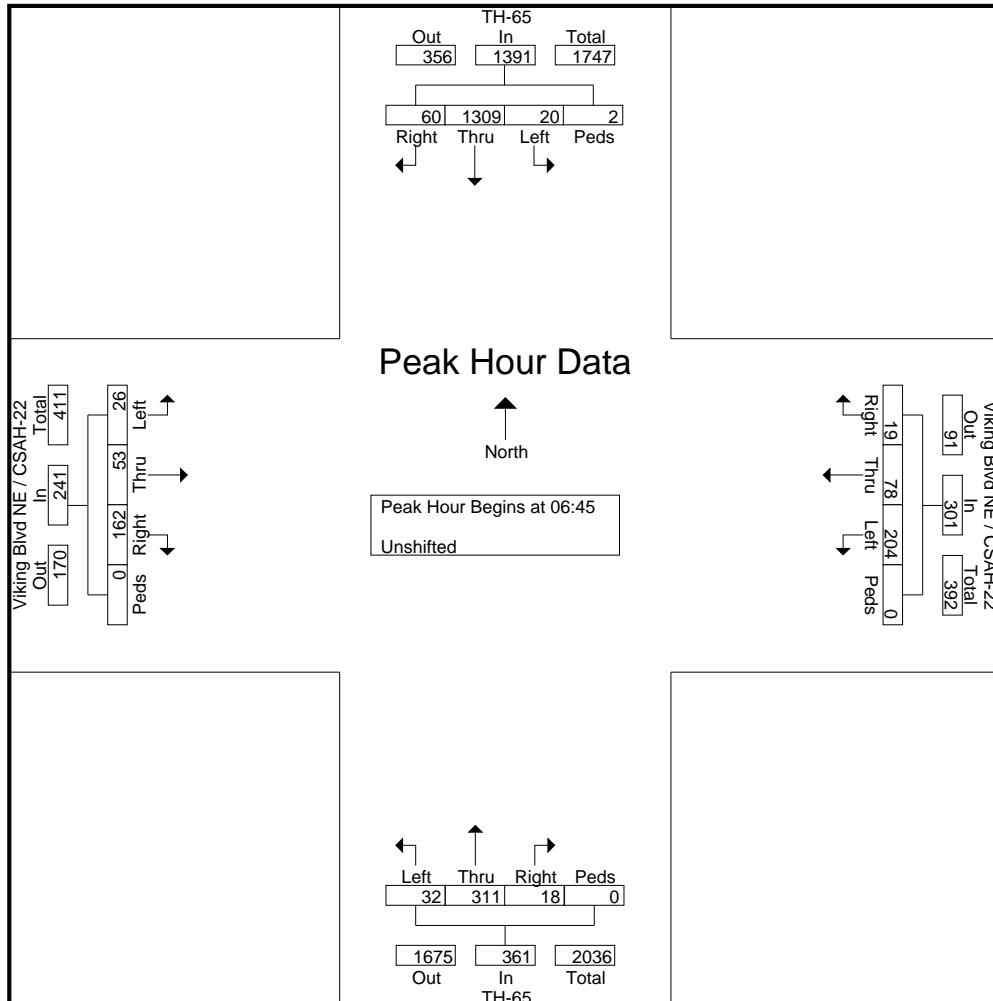

Alliant Engineering Inc Minneapolis, MN 55415

TH-65 at Viking Blvd NE / CSAH-22
 Ref.Pt.: 023.872 EAST BETHEL
 data by Alliant Engineering Inc
 TURN MOVEMENT COUNT

File Name : TH-65 at Viking Blvd NE CSAH-22 2009
 Site Code : 00000022
 Start Date : 1/20/2009
 Page No : 4

Start Time	TH-65 Southbound					Viking Blvd NE / CSAH-22 Westbound					TH-65 Northbound					Viking Blvd NE / CSAH-22 Eastbound					Int. Total
	Left	Thru	Right	Peds	App. Total	Left	Thru	Right	Peds	App. Total	Left	Thru	Right	Peds	App. Total	Left	Thru	Right	Peds	App. Total	
Peak Hour Analysis From 15:00 to 17:45 - Peak 1 of 1																					
Peak Hour for Entire Intersection Begins at 16:30																					
16:30	14	127	12	0	153	11	16	15	0	42	33	391	39	0	463	22	23	22	0	67	725
16:45	12	116	17	0	145	21	25	18	0	64	46	366	41	0	453	20	30	13	0	63	725
17:00	9	158	16	0	183	22	18	25	0	65	33	390	42	0	465	31	24	15	0	70	783
17:15	7	128	12	0	147	14	16	17	0	47	49	400	38	0	487	19	21	18	0	58	739
Total Volume	42	529	57	0	628	68	75	75	0	218	161	1547	160	0	1868	92	98	68	0	258	2972
% App. Total	6.7	84.2	9.1	0		31.2	34.4	34.4	0		8.6	82.8	8.6	0		35.7	38	26.4	0		
PHF	.750	.837	.838	.000	.858	.773	.750	.750	.000	.838	.821	.967	.952	.000	.959	.742	.817	.773	.000	.921	.949

