

Albeck Gerken, Inc

Transportation Engineers

Traffic Data Collection

Diffley Rd/ CSAH-30 at Nicols Rd
Eagan, MN
Ref.Pt.: east of TH-77
TURN MOVEMENT COUNT

File Name : 29 Diffley Rd at Nicols Rd
Site Code : 29
Start Date : 4/12/2012
Page No : 1

Groups Printed- Cars - Heavy Vehicles

Start Time	Nicols Rd Southbound				Diffley Rd / CSAH-30 Westbound				Nicols Rd Northbound				Diffley Rd / CSAH-30 Eastbound				Int. Total
	Left	Thru	Right	Peds	Left	Thru	Right	Peds	Left	Thru	Right	Peds	Left	Thru	Right	Peds	
06:00	0	3	5	1	2	94	2	0	12	8	8	0	3	16	7	0	161
06:15	1	2	10	0	2	111	1	0	20	5	5	0	1	33	6	0	197
06:30	0	5	14	0	6	179	2	0	25	6	13	0	8	34	8	1	301
06:45	2	2	10	0	7	185	1	0	21	7	15	1	7	38	5	0	301
Total	3	12	39	1	17	569	6	0	78	26	41	1	19	121	26	1	960
07:00	2	5	17	1	7	200	14	1	29	10	10	0	11	36	9	1	353
07:15	7	4	16	0	9	214	4	0	39	13	7	2	19	54	25	0	413
07:30	0	10	15	0	13	242	5	0	33	20	14	0	27	68	18	0	465
07:45	1	13	18	0	18	205	1	0	34	15	13	0	20	55	14	0	407
Total	10	32	66	1	47	861	24	1	135	58	44	2	77	213	66	1	1638
08:00	3	8	10	1	13	171	9	2	28	17	13	0	17	45	15	0	352
08:15	2	6	14	0	9	160	0	0	38	9	13	0	8	54	18	0	331
08:30	0	8	12	0	15	157	3	0	21	9	9	0	13	47	17	0	311
08:45	1	11	11	0	11	138	2	0	20	6	8	0	9	51	19	0	287
Total	6	33	47	1	48	626	14	2	107	41	43	0	47	197	69	0	1281
09:00	0	11	15	0	8	100	7	1	20	10	14	1	7	55	8	0	257
09:15	2	7	5	1	16	107	5	1	14	5	7	0	8	35	13	2	228
09:30	1	5	12	0	14	97	3	0	29	11	14	0	7	49	21	0	263
09:45	1	4	10	0	9	85	4	1	16	4	5	0	6	52	14	0	211
Total	4	27	42	1	47	389	19	3	79	30	40	1	28	191	56	2	959
10:00	1	5	8	1	9	65	2	0	21	10	9	0	15	47	8	0	201
10:15	6	6	9	0	3	75	2	1	26	3	8	0	11	43	4	0	197
10:30	3	4	9	0	13	80	3	0	11	10	8	0	13	50	5	0	209
10:45	2	11	7	0	13	78	1	0	10	4	9	0	7	36	8	0	186
Total	12	26	33	1	38	298	8	1	68	27	34	0	46	176	25	0	793
11:00	2	10	13	2	5	74	1	0	10	8	10	0	14	51	13	0	213
11:15	1	6	15	1	6	59	0	5	17	8	11	0	13	44	13	0	199
11:30	5	4	13	3	14	52	0	0	15	9	11	0	7	56	12	0	201
11:45	3	10	11	0	11	75	0	0	15	6	10	0	15	47	22	0	225
Total	11	30	52	6	36	260	1	5	57	31	42	0	49	198	60	0	838
12:00	2	6	11	1	11	55	8	1	23	9	14	0	14	62	22	0	239
12:15	3	11	7	0	10	62	2	1	16	6	15	0	5	64	19	0	221
12:30	4	9	10	1	7	55	6	3	13	7	5	0	6	59	17	0	202
12:45	3	11	9	1	11	81	1	0	16	7	12	0	8	50	21	0	231
Total	12	37	37	3	39	253	17	5	68	29	46	0	33	235	79	0	893
13:00	2	2	10	0	12	54	1	0	25	10	4	0	5	59	14	2	200
13:15	3	7	18	1	10	75	1	0	11	10	21	0	12	72	19	0	260
13:30	1	14	10	0	11	71	6	0	19	12	11	1	13	74	27	0	270
13:45	1	12	20	5	11	63	5	0	16	5	14	4	13	73	20	0	262
Total	7	35	58	6	44	263	13	0	71	37	50	5	43	278	80	2	992
14:00	10	8	26	1	12	75	8	2	22	12	9	1	19	92	13	0	310
14:15	6	18	14	0	7	54	3	3	22	6	22	0	21	112	20	0	308
14:30	0	5	15	4	13	93	2	3	18	12	18	3	8	117	15	3	329
14:45	4	9	14	2	13	98	4	0	11	9	22	0	14	120	27	1	348
Total	20	40	69	7	45	320	17	8	73	39	71	4	62	441	75	4	1295
15:00	8	10	13	0	14	103	1	1	19	15	22	0	20	123	25	0	374
15:15	7	7	19	0	16	101	3	1	17	7	13	0	14	153	27	0	385
15:30	2	16	10	0	12	105	4	0	11	16	14	0	13	163	22	0	388
15:45	2	9	12	0	14	112	1	1	24	13	14	0	18	168	24	0	412
Total	19	42	54	0	56	421	9	3	71	51	63	0	65	607	98	0	1559

Albeck Gerken, Inc

Transportation Engineers

Traffic Data Collection

Diffley Rd/ CSAH-30 at Nicols Rd

Eagan, MN

Ref.Pt.: east of TH-77

TURN MOVEMENT COUNT

File Name : 29 Diffley Rd at Nicols Rd

Site Code : 29

Start Date : 4/12/2012

Page No : 2

Groups Printed- Cars - Heavy Vehicles

Start Time	Nicols Rd Southbound				Diffley Rd / CSAH-30 Westbound				Nicols Rd Northbound				Diffley Rd / CSAH-30 Eastbound				Int. Total
	Left	Thru	Right	Peds	Left	Thru	Right	Peds	Left	Thru	Right	Peds	Left	Thru	Right	Peds	
16:00	6	11	16	1	14	85	2	0	24	13	22	2	21	149	31	2	399
16:15	5	12	13	1	14	98	8	2	20	21	18	0	18	175	32	1	438
16:30	8	13	11	0	17	90	5	0	20	13	19	0	20	185	40	0	441
16:45	10	14	10	1	15	101	0	0	24	8	18	0	21	209	37	1	469
Total	29	50	50	3	60	374	15	2	88	55	77	2	80	718	140	4	1747
17:00	8	9	20	0	13	112	12	1	13	16	24	1	28	197	35	1	490
17:15	10	12	9	1	27	111	5	1	34	16	21	1	29	205	29	0	511
17:30	0	9	9	0	21	126	3	3	19	7	23	4	18	203	34	1	480
17:45	3	22	17	1	25	89	5	0	17	17	23	2	20	190	22	0	453
Total	21	52	55	2	86	438	25	5	83	56	91	8	95	795	120	2	1934
18:00	10	15	12	0	17	92	12	3	18	15	29	1	22	154	28	0	428
18:15	17	11	14	1	13	94	8	1	19	13	28	2	25	142	27	0	415
18:30	5	7	13	0	19	95	8	3	14	8	18	2	19	160	21	0	392
18:45	2	10	15	0	17	115	3	0	14	9	22	0	13	149	19	0	388
Total	34	43	54	1	66	396	31	7	65	45	97	5	79	605	95	0	1623
Grand Total	188	459	656	33	629	5468	199	42	1043	525	739	28	723	4775	989	16	16512
Apprch %	14.1	34.4	49.1	2.5	9.9	86.3	3.1	0.7	44.7	22.5	31.6	1.2	11.1	73.4	15.2	0.2	
Total %	1.1	2.8	4	0.2	3.8	33.1	1.2	0.3	6.3	3.2	4.5	0.2	4.4	28.9	6	0.1	
Cars	159	440	520	30	610	5389	166	35	1015	508	721	18	577	4713	964	14	15879
% Cars	84.6	95.9	79.3	90.9	97	98.6	83.4	83.3	97.3	96.8	97.6	64.3	79.8	98.7	97.5	87.5	96.2
Heavy Vehicles	29	19	136	3	19	79	33	7	28	17	18	10	146	62	25	2	633
% Heavy Vehicles	15.4	4.1	20.7	9.1	3	1.4	16.6	16.7	2.7	3.2	2.4	35.7	20.2	1.3	2.5	12.5	3.8

Albeck Gerken, Inc

Transportation Engineers

Traffic Data Collection

Diffley Rd/ CSAH-30 at Nicols Rd
Eagan, MN
Ref.Pt.: east of TH-77
TURN MOVEMENT COUNT

File Name : 29 Diffley Rd at Nicols Rd
Site Code : 29
Start Date : 4/12/2012
Page No : 3

Start Time	Nicols Rd Southbound					Diffley Rd / CSAH-30 Westbound					Nicols Rd Northbound					Diffley Rd / CSAH-30 Eastbound					Int. Total
	Left	Thru	Right	Peds	App. Total	Left	Thru	Right	Peds	App. Total	Left	Thru	Right	Peds	App. Total	Left	Thru	Right	Peds	App. Total	
Peak Hour Analysis From 06:00 to 09:00 - Peak 1 of 1																					
Peak Hour for Entire Intersection Begins at 07:00																					
07:00	2	5	17	1	25	7	200	14	1	222	29	10	10	0	49	11	36	9	1	57	353
07:15	7	4	16	0	27	9	214	4	0	227	39	13	7	2	61	19	54	25	0	98	413
07:30	0	10	15	0	25	13	242	5	0	260	33	20	14	0	67	27	68	18	0	113	465
07:45	1	13	18	0	32	18	205	1	0	224	34	15	13	0	62	20	55	14	0	89	407
Total Volume	10	32	66	1	109	47	861	24	1	933	135	58	44	2	239	77	213	66	1	357	1638
% App. Total	9.2	29.4	60.6	0.9		5	92.3	2.6	0.1		56.5	24.3	18.4	0.8		21.6	59.7	18.5	0.3		
PHF	.357	.615	.917	.250	.852	.653	.889	.429	.250	.897	.865	.725	.786	.250	.892	.713	.783	.660	.250	.790	.881

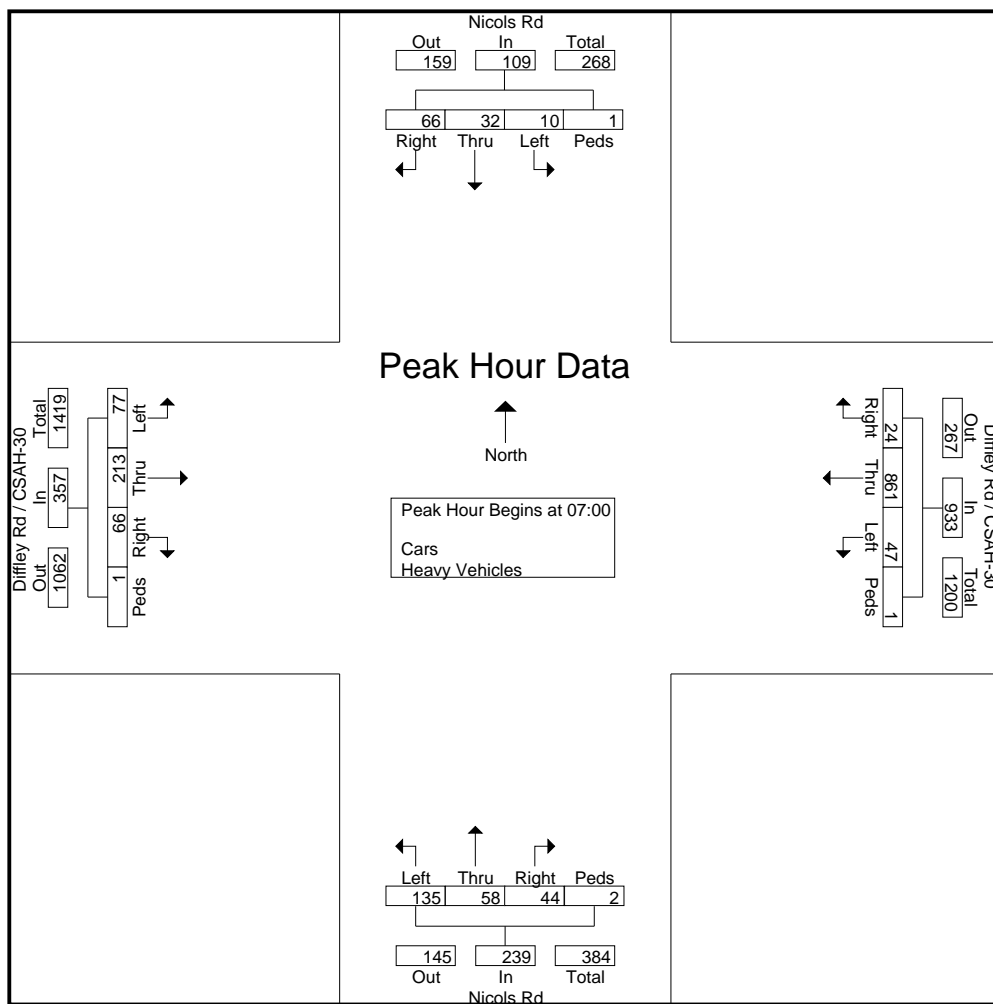

Albeck Gerken, Inc

Transportation Engineers

Traffic Data Collection

Diffley Rd/ CSAH-30 at Nicols Rd
Eagan, MN
Ref.Pt.: east of TH-77
TURN MOVEMENT COUNT

File Name : 29 Diffley Rd at Nicols Rd
Site Code : 29
Start Date : 4/12/2012
Page No : 4

Start Time	Nicols Rd Southbound					Diffley Rd / CSAH-30 Westbound					Nicols Rd Northbound					Diffley Rd / CSAH-30 Eastbound					Int. Total
	Left	Thru	Right	Peds	App. Total	Left	Thru	Right	Peds	App. Total	Left	Thru	Right	Peds	App. Total	Left	Thru	Right	Peds	App. Total	
Peak Hour Analysis From 15:00 to 18:45 - Peak 1 of 1																					
Peak Hour for Entire Intersection Begins at 16:45																					
16:45	10	14	10	1	35	15	101	0	0	116	24	8	18	0	50	21	209	37	1	268	469
17:00	8	9	20	0	37	13	112	12	1	138	13	16	24	1	54	28	197	35	1	261	490
17:15	10	12	9	1	32	27	111	5	1	144	34	16	21	1	72	29	205	29	0	263	511
17:30	0	9	9	0	18	21	126	3	3	153	19	7	23	4	53	18	203	34	1	256	480
Total Volume	28	44	48	2	122	76	450	20	5	551	90	47	86	6	229	96	814	135	3	1048	1950
% App. Total	23	36.1	39.3	1.6		13.8	81.7	3.6	0.9		39.3	20.5	37.6	2.6		9.2	77.7	12.9	0.3		
PHF	.700	.786	.600	.500	.824	.704	.893	.417	.417	.900	.662	.734	.896	.375	.795	.828	.974	.912	.750	.978	.954

