

MN Dept of Transportation

TRAFFIC DATA COLLECTION - Metro

TH-95 at 110th St (Cottage Grove)
 Ref.Pt.: 126.439
 video
 TURN MOVEMENT COUNT

File Name : TH-95 at 110th St 2015
 Site Code :
 Start Date : 5/18/2015
 Page No : 1

Groups Printed- Cars +

Start Time	TH-95 Southbound				110th Street Westbound				TH-95 Northbound				private driveway Eastbound				Int. Total
	Left	Thru	Right	Peds	Left	Thru	Right	Peds	Left	Thru	Right	Peds	Left	Thru	Right	Peds	
06:00	0	23	0	0	6	0	1	0	0	10	1	0	0	0	0	0	41
06:15	1	25	0	0	16	0	0	0	0	37	1	0	0	0	0	0	80
06:30	2	33	0	0	9	0	0	0	0	24	2	0	0	0	0	0	70
06:45	0	31	0	0	4	0	3	0	0	30	2	0	0	0	0	0	70
Total	3	112	0	0	35	0	4	0	0	101	6	0	0	0	0	0	261
07:00	0	31	0	0	15	0	3	0	0	39	3	0	0	0	0	0	91
07:15	0	44	0	0	17	0	1	0	0	37	4	0	0	0	0	0	103
07:30	0	42	0	0	11	0	1	0	1	45	6	0	0	0	0	0	106
07:45	0	52	0	0	13	0	4	0	0	46	5	0	0	0	1	0	121
Total	0	169	0	0	56	0	9	0	1	167	18	0	0	0	1	0	421
08:00	1	45	0	0	10	0	1	0	0	34	4	0	0	0	0	0	95
08:15	2	34	0	0	7	0	1	0	0	32	4	0	0	0	0	0	80
08:30	0	26	0	0	3	0	0	0	0	20	2	0	0	0	0	0	51
08:45	3	31	0	0	7	0	1	0	0	27	2	0	0	0	0	0	71
Total	6	136	0	0	27	0	3	0	0	113	12	0	0	0	0	0	297
*****BREAK*****																	
15:00	4	35	0	0	7	0	2	0	0	32	10	0	0	0	0	0	90
15:15	2	33	0	0	8	0	2	0	0	30	7	0	0	0	0	0	82
15:30	2	41	0	0	7	0	1	0	0	43	11	0	0	0	0	0	105
15:45	4	43	0	0	11	0	3	0	0	36	1	0	0	0	0	0	98
Total	12	152	0	0	33	0	8	0	0	141	29	0	0	0	0	0	375
16:00	0	44	0	0	7	1	0	0	0	43	9	0	0	0	0	0	104
16:15	2	43	0	0	6	0	1	0	1	46	5	0	1	0	0	0	105
16:30	0	39	0	0	6	0	2	0	1	45	8	0	0	0	1	0	102
16:45	0	44	0	0	6	0	3	0	0	47	7	0	0	0	0	0	107
Total	2	170	0	0	25	1	6	0	2	181	29	0	1	0	1	0	418
17:00	1	55	0	0	9	0	0	0	1	34	18	0	0	1	0	0	119
17:15	6	42	0	0	5	0	1	0	0	48	10	0	0	0	0	0	112
17:30	5	50	0	0	6	0	2	0	0	51	17	0	0	0	0	0	131
17:45	2	46	0	0	7	0	1	0	0	49	8	0	0	0	0	0	113
Total	14	193	0	0	27	0	4	0	1	182	53	0	0	1	0	0	475
Grand Total	37	932	0	0	203	1	34	0	4	885	147	0	1	1	2	0	2247
Apprch %	3.8	96.2	0	0	85.3	0.4	14.3	0	0.4	85.4	14.2	0	25	25	50	0	
Total %	1.6	41.5	0	0	9	0	1.5	0	0.2	39.4	6.5	0	0	0	0.1	0	

MN Dept of Transportation

TRAFFIC DATA COLLECTION - Metro

TH-95 at 110th St (Cottage Grove)
 Ref.Pt.: 126.439
 video
 TURN MOVEMENT COUNT

File Name : TH-95 at 110th St 2015
 Site Code :
 Start Date : 5/18/2015
 Page No : 2

Start Time	TH-95 Southbound					110th Street Westbound					TH-95 Northbound					private driveway Eastbound					Int. Total
	Left	Thru	Right	Peds	App. Total	Left	Thru	Right	Peds	App. Total	Left	Thru	Right	Peds	App. Total	Left	Thru	Right	Peds	App. Total	
Peak Hour Analysis From 06:00 to 08:45 - Peak 1 of 1																					
Peak Hour for Entire Intersection Begins at 07:15																					
07:15	0	44	0	0	44	17	0	1	0	18	0	37	4	0	41	0	0	0	0	0	103
07:30	0	42	0	0	42	11	0	1	0	12	1	45	6	0	52	0	0	0	0	0	106
07:45	0	52	0	0	52	13	0	4	0	17	0	46	5	0	51	0	0	1	0	1	121
08:00	1	45	0	0	46	10	0	1	0	11	0	34	4	0	38	0	0	0	0	0	95
Total Volume	1	183	0	0	184	51	0	7	0	58	1	162	19	0	182	0	0	1	0	1	425
% App. Total	0.5	99.5	0	0		87.9	0	12.1	0		0.5	89	10.4	0		0	0	100	0		
PHF	.250	.880	.000	.000	.885	.750	.000	.438	.000	.806	.250	.880	.792	.000	.875	.000	.000	.250	.000	.250	.878

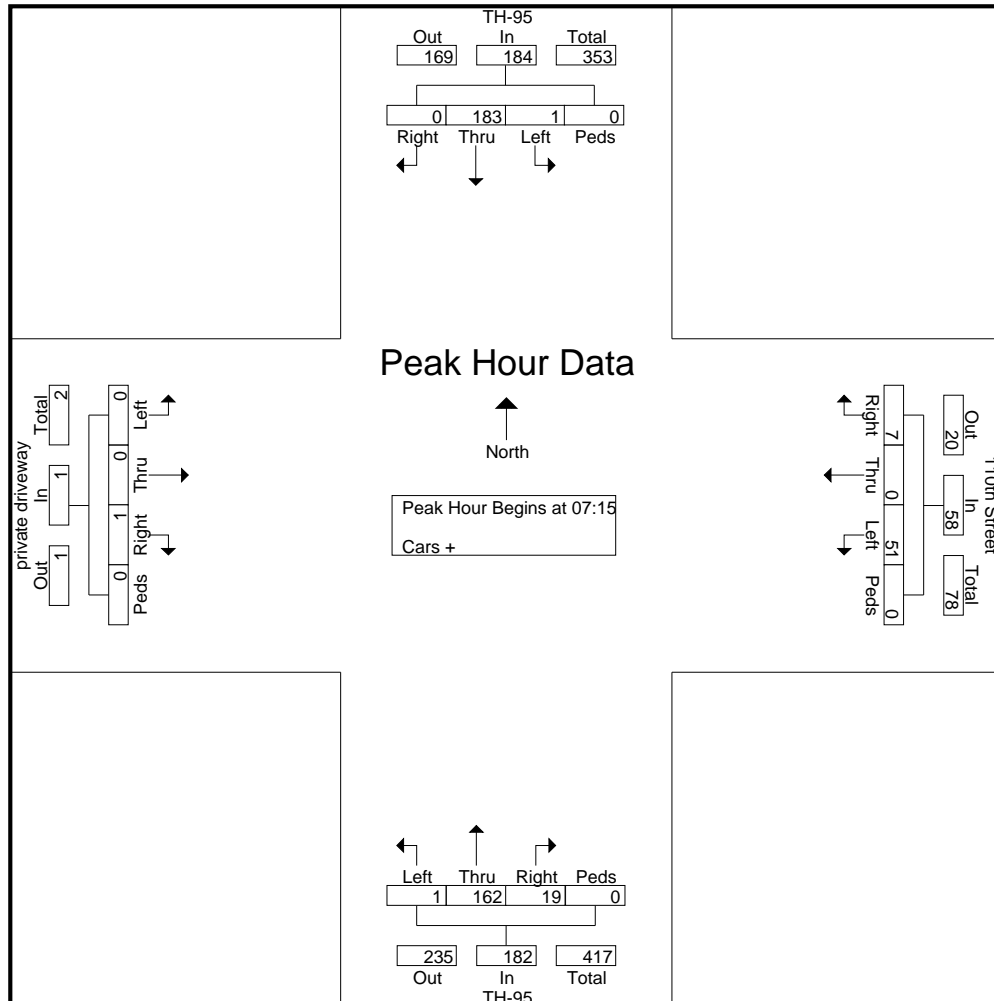

MN Dept of Transportation

TRAFFIC DATA COLLECTION - Metro

TH-95 at 110th St (Cottage Grove)
 Ref.Pt.: 126.439
 video
 TURN MOVEMENT COUNT

File Name : TH-95 at 110th St 2015
 Site Code :
 Start Date : 5/18/2015
 Page No : 3

Start Time	TH-95 Southbound					110th Street Westbound					TH-95 Northbound					private driveway Eastbound					Int. Total
	Left	Thru	Right	Peds	App. Total	Left	Thru	Right	Peds	App. Total	Left	Thru	Right	Peds	App. Total	Left	Thru	Right	Peds	App. Total	
Peak Hour Analysis From 15:00 to 17:45 - Peak 1 of 1																					
Peak Hour for Entire Intersection Begins at 17:00																					
17:00	1	55	0	0	56	9	0	0	0	9	1	34	18	0	53	0	1	0	0	1	119
17:15	6	42	0	0	48	5	0	1	0	6	0	48	10	0	58	0	0	0	0	0	112
17:30	5	50	0	0	55	6	0	2	0	8	0	51	17	0	68	0	0	0	0	0	131
17:45	2	46	0	0	48	7	0	1	0	8	0	49	8	0	57	0	0	0	0	0	113
Total Volume	14	193	0	0	207	27	0	4	0	31	1	182	53	0	236	0	1	0	0	1	475
% App. Total	6.8	93.2	0	0		87.1	0	12.9	0		0.4	77.1	22.5	0		0	100	0	0		
PHF	.583	.877	.000	.000	.924	.750	.000	.500	.000	.861	.250	.892	.736	.000	.868	.000	.250	.000	.000	.250	.906

