



MINNESOTA DEPT OF TRANSPORTATION

TRAFFIC DATA COLLECTION - METRO

TH-96 at Stonebridge Trail
 Ref.Pt.: 018465
 JAMAR # T-2582 CR
 TURN MOVEMENT COUNT

File Name : TH-96 at Stonebridge Trail 2009
 Site Code : 00000000
 Start Date : 5/6/2009
 Page No : 1

Groups Printed- Cars & Trucks

Start Time	STONEBRIDGE TRAIL Southbound				TH-96 Westbound				STONEBRIDGE TRAIL Northbound				TH-96 Eastbound				Int. Total
	Left	Thru	Right	Peds	Left	Thru	Right	Peds	Left	Thru	Right	Peds	Left	Thru	Right	Peds	
06:00	0	13	25	0	1	24	0	0	0	0	0	0	0	7	0	0	70
06:15	0	8	30	0	2	27	1	0	0	3	0	0	1	13	0	0	85
06:30	1	12	17	0	12	39	0	0	0	2	2	0	9	8	1	0	103
06:45	1	26	19	0	2	52	0	0	0	3	0	0	8	20	0	1	132
Total	2	59	91	0	17	142	1	0	0	8	2	0	18	48	1	1	390
07:00	2	26	25	0	6	50	1	0	0	4	3	0	3	22	0	0	142
07:15	1	33	34	0	6	38	0	1	0	6	1	0	3	25	0	0	148
07:30	2	24	28	2	5	52	1	0	0	7	5	0	0	18	0	0	144
07:45	0	22	25	0	1	29	0	0	0	14	1	0	4	18	0	0	114
Total	5	105	112	2	18	169	2	1	0	31	10	0	10	83	0	0	548
08:00	0	16	21	0	3	25	0	0	0	15	3	0	8	23	0	1	115
08:15	0	22	16	1	3	14	1	0	0	5	5	0	8	25	0	0	100
08:30	0	30	12	0	4	28	1	0	0	8	4	0	4	28	0	0	119
08:45	1	33	17	0	10	21	0	0	0	9	1	0	6	21	0	0	119
Total	1	101	66	1	20	88	2	0	0	37	13	0	26	97	0	1	453
15:00	0	5	9	0	4	18	1	0	0	26	3	0	13	24	0	0	103
15:15	0	9	8	0	2	20	0	0	0	17	6	0	16	25	0	0	103
15:30	1	12	6	0	2	20	0	0	0	25	6	0	15	28	0	0	115
15:45	0	11	7	0	2	13	0	0	0	22	7	0	20	28	0	0	110
Total	1	37	30	0	10	71	1	0	0	90	22	0	64	105	0	0	431
16:00	0	14	7	0	5	18	0	0	0	21	11	0	15	35	0	0	126
16:15	0	11	10	0	4	20	2	0	0	25	8	0	18	42	0	0	140
16:30	1	13	9	0	3	29	0	0	0	29	5	0	16	35	1	0	141
16:45	2	9	6	0	3	26	1	0	0	29	9	0	25	25	0	0	135
Total	3	47	32	0	15	93	3	0	0	104	33	0	74	137	1	0	542
17:00	0	27	7	0	4	32	0	0	0	29	6	0	21	31	0	0	157
17:15	0	11	7	0	2	25	2	0	0	31	5	0	10	36	0	0	129
17:30	0	19	7	0	4	22	1	0	0	37	5	0	24	35	1	1	156
17:45	0	18	11	0	4	21	1	0	0	34	10	0	23	47	0	0	169
Total	0	75	32	0	14	100	4	0	0	131	26	0	78	149	1	1	611
Grand Total	12	424	363	3	94	663	13	1	0	401	106	0	270	619	3	3	2975
Apprch %	1.5	52.9	45.3	0.4	12.2	86	1.7	0.1	0	79.1	20.9	0	30.2	69.2	0.3	0.3	
Total %	0.4	14.3	12.2	0.1	3.2	22.3	0.4	0	0	13.5	3.6	0	9.1	20.8	0.1	0.1	



MINNESOTA DEPT OF TRANSPORTATION

TRAFFIC DATA COLLECTION - METRO

TH-96 at Stonebridge Trail
 Ref.Pt.: 018465
 JAMAR # T-2582 CR
 TURN MOVEMENT COUNT

File Name : TH-96 at Stonebridge Trail 2009
 Site Code : 00000000
 Start Date : 5/6/2009
 Page No : 2

Start Time	STONEBRIDGE TRAIL Southbound					TH-96 Westbound					STONEBRIDGE TRAIL Northbound					TH-96 Eastbound					Int. Total
	Left	Thru	Right	Peds	App. Total	Left	Thru	Right	Peds	App. Total	Left	Thru	Right	Peds	App. Total	Left	Thru	Right	Peds	App. Total	
Peak Hour Analysis From 06:00 to 08:45 - Peak 1 of 1																					
Peak Hour for Entire Intersection Begins at 06:45																					
06:45	1	26	19	0	46	2	52	0	0	54	0	3	0	0	3	8	20	0	1	29	132
07:00	2	26	25	0	53	6	50	1	0	57	0	4	3	0	7	3	22	0	0	25	142
07:15	1	33	34	0	68	6	38	0	1	45	0	6	1	0	7	3	25	0	0	28	148
07:30	2	24	28	2	56	5	52	1	0	58	0	7	5	0	12	0	18	0	0	18	144
Total Volume	6	109	106	2	223	19	192	2	1	214	0	20	9	0	29	14	85	0	1	100	566
% App. Total	2.7	48.9	47.5	0.9		8.9	89.7	0.9	0.5		0	69	31	0		14	85	0	1		
PHF	.750	.826	.779	.250	.820	.792	.923	.500	.250	.922	.000	.714	.450	.000	.604	.438	.850	.000	.250	.862	.956

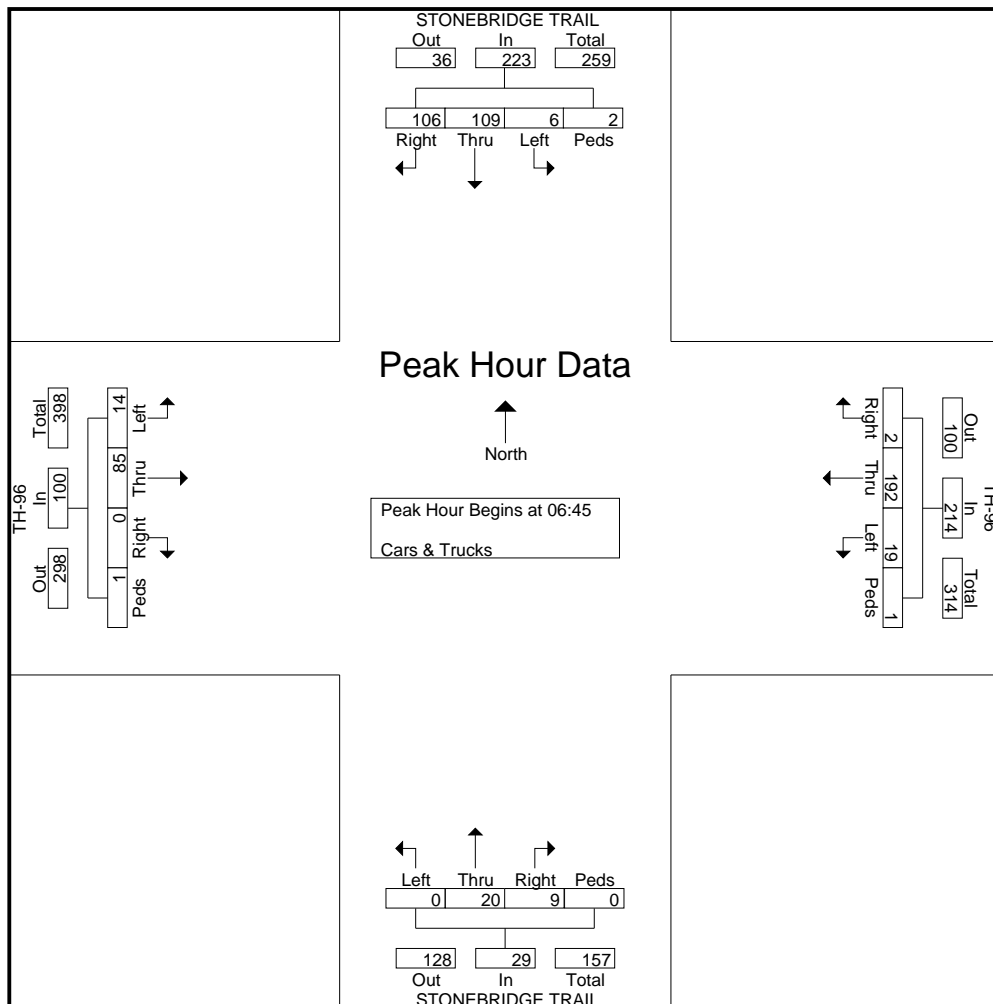



MINNESOTA DEPT OF TRANSPORTATION

TRAFFIC DATA COLLECTION - METRO

TH-96 at Stonebridge Trail
 Ref.Pt.: 018465
 JAMAR # T-2582 CR
 TURN MOVEMENT COUNT

File Name : TH-96 at Stonebridge Trail 2009
 Site Code : 00000000
 Start Date : 5/6/2009
 Page No : 3

Start Time	STONEBRIDGE TRAIL Southbound					TH-96 Westbound					STONEBRIDGE TRAIL Northbound					TH-96 Eastbound					Int. Total
	Left	Thru	Right	Peds	App. Total	Left	Thru	Right	Peds	App. Total	Left	Thru	Right	Peds	App. Total	Left	Thru	Right	Peds	App. Total	
Peak Hour Analysis From 15:00 to 17:45 - Peak 1 of 1																					
Peak Hour for Entire Intersection Begins at 17:00																					
17:00	0	27	7	0	34	4	32	0	0	36	0	29	6	0	35	21	31	0	0	52	157
17:15	0	11	7	0	18	2	25	2	0	29	0	31	5	0	36	10	36	0	0	46	129
17:30	0	19	7	0	26	4	22	1	0	27	0	37	5	0	42	24	35	1	1	61	156
17:45	0	18	11	0	29	4	21	1	0	26	0	34	10	0	44	23	47	0	0	70	169
Total Volume	0	75	32	0	107	14	100	4	0	118	0	131	26	0	157	78	149	1	1	229	611
% App. Total	0	70.1	29.9	0		11.9	84.7	3.4	0		0	83.4	16.6	0		34.1	65.1	0.4	0.4		
PHF	.000	.694	.727	.000	.787	.875	.781	.500	.000	.819	.000	.885	.650	.000	.892	.813	.793	.250	.250	.818	.904

