



# MINNESOTA DEPT OF TRANSPORTATION

## TRAFFIC DATA COLLECTION - METRO

TH-12 AT CSAH-83 / HALGREN RD.  
 Ref.Pt.: 146.062 MAPLE PLAIN  
 JAMAR # T-1386 KF  
 TURN MOVEMENT COUNT

File Name : TH-12 AT CSAH-83 INDEPENDENCE 2007  
 Site Code : 00000000  
 Start Date : 10/17/2007  
 Page No : 1

### Groups Printed- Cars & Trucks

Start Time	CSAH-83 / HALGREN RD Southbound				TH-12 Westbound				CSAH-83 / HALGREN RD Northbound				TH-12 Eastbound				Int. Total
	Left	Thru	Right	Peds	Left	Thru	Right	Peds	Left	Thru	Right	Peds	Left	Thru	Right	Peds	
06:00	9	0	3	0	3	24	3	0	5	2	25	0	4	221	5	0	304
06:15	1	0	0	0	2	43	2	0	6	2	19	0	4	244	5	0	328
06:30	0	0	2	0	5	47	2	0	6	3	29	0	4	286	13	0	397
06:45	2	0	0	0	9	72	6	0	16	5	25	0	6	280	7	0	428
Total	12	0	5	0	19	186	13	0	33	12	98	0	18	1031	30	0	1457
07:00	0	0	2	0	14	78	1	0	9	2	35	0	8	265	4	0	418
07:15	2	1	1	0	8	69	2	0	12	4	58	0	4	273	10	0	444
07:30	0	3	2	0	11	69	3	0	28	2	48	0	9	241	8	0	424
07:45	1	1	1	0	13	91	9	0	12	7	21	0	8	182	8	0	354
Total	3	5	6	0	46	307	15	0	61	15	162	0	29	961	30	0	1640
08:00	2	0	0	0	11	65	12	0	5	4	26	0	2	188	5	0	320
08:15	0	0	2	0	18	62	2	0	8	10	36	0	3	179	4	0	324
08:30	3	1	0	0	10	65	1	0	9	2	24	0	4	142	6	0	267
08:45	2	0	0	0	8	63	4	0	8	7	18	0	5	155	8	0	278
Total	7	1	2	0	47	255	19	0	30	23	104	0	14	664	23	0	1189
*** BREAK ***																	
15:00	9	4	9	0	17	178	1	0	13	3	15	0	2	100	9	0	360
15:15	4	7	15	0	22	205	3	0	15	5	13	0	2	102	4	0	397
15:30	10	5	7	0	20	193	9	0	26	4	21	0	3	107	10	0	415
15:45	4	5	5	0	28	207	4	0	17	5	12	0	2	72	6	0	367
Total	27	21	36	0	87	783	17	0	71	17	61	0	9	381	29	0	1539
16:00	7	7	17	0	20	244	4	0	16	3	31	0	2	106	11	0	468
16:15	12	5	5	0	25	216	4	0	22	2	20	0	1	68	10	0	390
16:30	7	4	11	0	24	224	1	0	17	4	13	0	1	106	11	0	423
16:45	6	6	5	0	33	236	2	0	28	5	23	0	9	90	11	0	454
Total	32	22	38	0	102	920	11	0	83	14	87	0	13	370	43	0	1735
17:00	11	9	14	0	29	210	4	0	33	0	22	0	1	100	8	0	441
17:15	6	5	3	0	22	252	1	0	19	6	17	0	0	110	6	0	447
17:30	7	6	5	0	24	209	1	0	16	1	17	0	2	87	7	0	382
17:45	3	8	6	0	26	172	1	0	13	0	15	0	1	73	4	0	322
Total	27	28	28	0	101	843	7	0	81	7	71	0	4	370	25	0	1592
Grand Total	108	77	115	0	402	3294	82	0	359	88	583	0	87	3777	180	0	9152
Apprch %	36	25.7	38.3	0	10.6	87.2	2.2	0	34.9	8.5	56.6	0	2.2	93.4	4.5	0	
Total %	1.2	0.8	1.3	0	4.4	36	0.9	0	3.9	1	6.4	0	1	41.3	2	0	



# MINNESOTA DEPT OF TRANSPORTATION

## TRAFFIC DATA COLLECTION - METRO

TH-12 AT CSAH-83 / HALGREN RD.  
 Ref.Pt.: 146.062 MAPLE PLAIN  
 JAMAR # T-1386 KF  
 TURN MOVEMENT COUNT

File Name : TH-12 AT CSAH-83 INDEPENDENCE 2007  
 Site Code : 00000000  
 Start Date : 10/17/2007  
 Page No : 2

Start Time	CSAH-83 / HALGREN RD Southbound					TH-12 Westbound					CSAH-83 / HALGREN RD Northbound					TH-12 Eastbound					Int. Total
	Left	Thru	Right	Peds	App. Total	Left	Thru	Right	Peds	App. Total	Left	Thru	Right	Peds	App. Total	Left	Thru	Right	Peds	App. Total	
Peak Hour Analysis From 06:00 to 08:45 - Peak 1 of 1																					
Peak Hour for Entire Intersection Begins at 06:45																					
06:45	2	0	0	0	2	9	72	6	0	87	16	5	25	0	46	6	280	7	0	293	428
07:00	0	0	2	0	2	14	78	1	0	93	9	2	35	0	46	8	265	4	0	277	418
07:15	2	1	1	0	4	8	69	2	0	79	12	4	58	0	74	4	273	10	0	287	444
07:30	0	3	2	0	5	11	69	3	0	83	28	2	48	0	78	9	241	8	0	258	424
Total Volume	4	4	5	0	13	42	288	12	0	342	65	13	166	0	244	27	1059	29	0	1115	1714
% App. Total	30.8	30.8	38.5	0		12.3	84.2	3.5	0		26.6	5.3	68	0		2.4	95	2.6	0		
PHF	.500	.333	.625	.000	.650	.750	.923	.500	.000	.919	.580	.650	.716	.000	.782	.750	.946	.725	.000	.951	.965

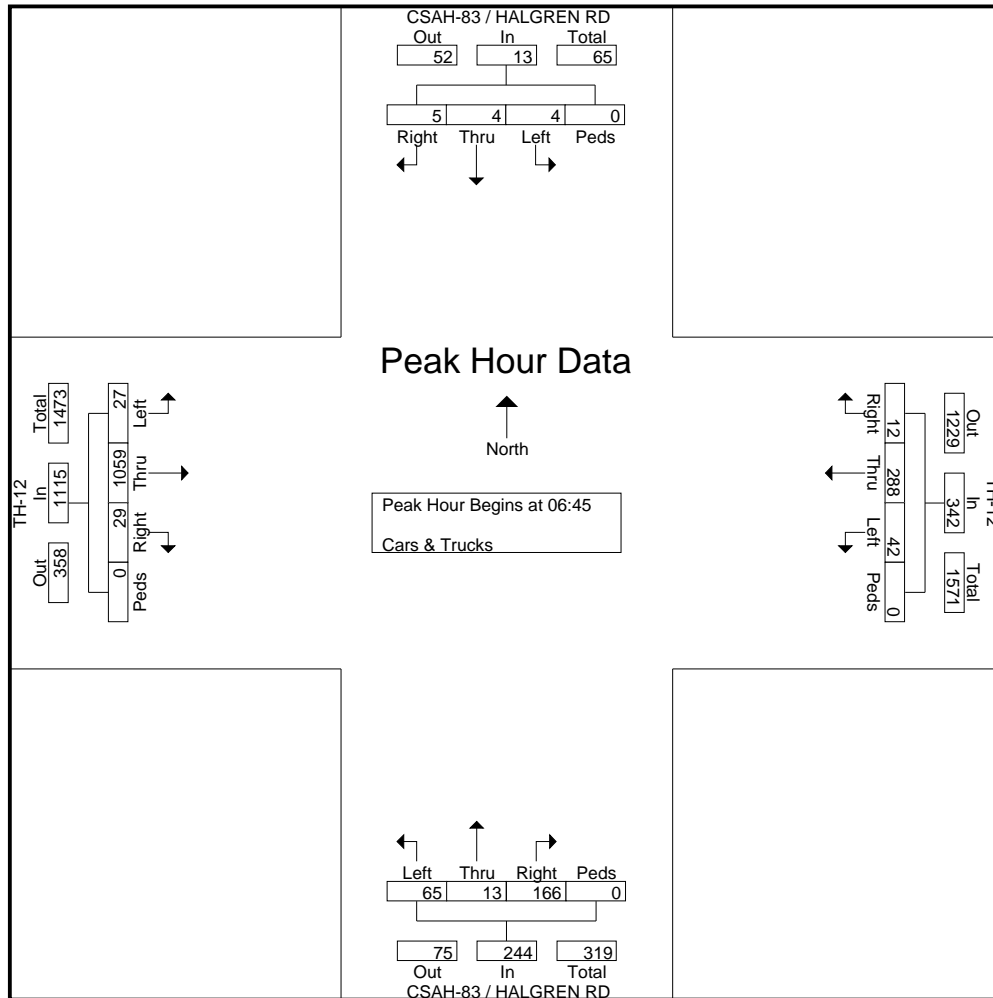



# MINNESOTA DEPT OF TRANSPORTATION

## TRAFFIC DATA COLLECTION - METRO

TH-12 AT CSAH-83 / HALGREN RD.  
 Ref.Pt.: 146.062 MAPLE PLAIN  
 JAMAR # T-1386 KF  
 TURN MOVEMENT COUNT

File Name : TH-12 AT CSAH-83 INDEPENDENCE 2007  
 Site Code : 00000000  
 Start Date : 10/17/2007  
 Page No : 3

Start Time	CSAH-83 / HALGREN RD Southbound					TH-12 Westbound					CSAH-83 / HALGREN RD Northbound					TH-12 Eastbound					Int. Total
	Left	Thru	Right	Peds	App. Total	Left	Thru	Right	Peds	App. Total	Left	Thru	Right	Peds	App. Total	Left	Thru	Right	Peds	App. Total	
Peak Hour Analysis From 15:00 to 17:45 - Peak 1 of 1																					
Peak Hour for Entire Intersection Begins at 16:30																					
16:30	7	4	11	0	22	24	224	1	0	249	17	4	13	0	34	1	106	11	0	118	423
16:45	6	6	5	0	17	33	236	2	0	271	28	5	23	0	56	9	90	11	0	110	454
17:00	11	9	14	0	34	29	210	4	0	243	33	0	22	0	55	1	100	8	0	109	441
17:15	6	5	3	0	14	22	252	1	0	275	19	6	17	0	42	0	110	6	0	116	447
Total Volume	30	24	33	0	87	108	922	8	0	1038	97	15	75	0	187	11	406	36	0	453	1765
% App. Total																					
PHF	.682	.667	.589	.000	.640	.818	.915	.500	.000	.944	.735	.625	.815	.000	.835	.306	.923	.818	.000	.960	.972

