



MINNESOTA DEPT OF TRANSPORTATION

TRAFFIC DATA COLLECTION - METRO

Location: TH 169 @ MILLER/DAYTON RD 2006
 REF. PT.: 145+00402
 Jamar# 1358/MAR
 TURN MOVEMENT COUNT

File Name : TH169A-3
 Site Code : 00000000
 Start Date : 5/3/2006
 Page No : 1

Groups Printed- Cars & Trucks

Start Time	TH 169 Southbound					MILLER RD/DAYTON RD Westbound					TH 169 Northbound					MILLER RD/DAYTON RD Eastbound					Int. Total
	LEFT	THRU	RIGHT	Peds	App. Total	LEFT	THRU	RIGHT	Peds	App. Total	LEFT	THRU	RIGHT	Peds	App. Total	LEFT	THRU	RIGHT	Peds	App. Total	
06:00	0	478	64	1	543	6	2	6	0	14	13	91	1	0	105	43	6	70	0	119	781
06:15	3	507	77	0	587	3	2	7	1	13	14	163	2	0	179	56	6	92	0	154	933
06:30	4	484	81	1	570	6	3	9	0	18	25	192	7	0	224	105	6	132	0	243	1055
06:45	4	533	109	0	646	4	2	9	0	15	23	233	2	0	258	123	7	149	0	279	1198
Total	11	2002	331	2	2346	19	9	31	1	60	75	679	12	0	766	327	25	443	0	795	3967
07:00	4	518	96	0	618	7	3	7	0	17	25	218	2	0	245	97	2	149	0	248	1128
07:15	4	539	82	0	625	8	8	19	0	35	30	287	4	0	321	130	6	183	1	320	1301
07:30	5	516	96	0	617	5	3	16	0	24	32	295	3	0	330	160	8	149	0	317	1288
07:45	4	510	95	0	609	7	9	12	0	28	29	313	6	0	348	171	11	136	0	318	1303
Total	17	2083	369	0	2469	27	23	54	0	104	116	1113	15	0	1244	558	27	617	1	1203	5020
08:00	3	438	79	0	520	8	4	7	0	19	32	217	3	0	252	107	4	107	0	218	1009
08:15	1	364	69	0	434	5	5	13	0	23	30	237	7	0	274	85	22	64	1	172	903
08:30	8	362	69	0	439	9	5	10	1	25	27	229	3	0	259	99	3	50	0	152	875
08:45	7	324	65	0	396	3	2	10	0	15	25	241	3	0	269	94	6	65	0	165	845
Total	19	1488	282	0	1789	25	16	40	1	82	114	924	16	0	1054	385	35	286	1	707	3632
11:00	8	254	40	0	302	4	2	7	1	14	26	245	6	3	280	44	1	40	0	85	681
11:15	8	285	51	1	345	2	4	5	0	11	21	273	4	0	298	63	3	34	0	100	754
11:30	6	292	63	0	361	10	5	9	0	24	27	278	5	0	310	50	4	38	2	94	789
11:45	7	322	51	0	380	6	3	12	0	21	41	220	1	0	262	62	7	36	0	105	768
Total	29	1153	205	1	1388	22	14	33	1	70	115	1016	16	3	1150	219	15	148	2	384	2992
12:00	8	251	44	2	305	9	4	11	1	25	29	253	7	0	289	68	6	34	0	108	727
12:15	3	290	56	0	349	5	3	11	0	19	36	292	6	1	335	69	5	30	0	104	807
12:30	12	255	41	0	308	7	2	16	0	25	37	317	7	0	361	70	9	47	0	126	820
12:45	3	260	48	0	311	7	5	11	0	23	19	279	1	0	299	59	5	43	0	107	740
Total	26	1056	189	2	1273	28	14	49	1	92	121	1141	21	1	1284	266	25	154	0	445	3094
15:00	6	293	113	0	412	7	6	17	0	30	56	301	7	0	364	94	4	34	0	132	938
15:15	2	309	101	0	412	8	4	12	2	26	41	395	3	0	439	124	3	36	2	165	1042
15:30	7	342	106	0	455	6	6	13	0	25	62	478	4	1	545	137	5	30	1	173	1198
15:45	11	298	114	0	423	12	5	13	1	31	31	342	1	1	375	181	10	31	1	223	1052
Total	26	1242	434	0	1702	33	21	55	3	112	190	1516	15	2	1723	536	22	131	4	693	4230
16:00	9	288	117	1	415	17	6	23	0	46	40	426	3	0	469	184	10	61	0	255	1185
16:15	10	305	136	1	452	8	9	26	1	44	41	435	1	0	477	183	7	48	1	239	1212
16:30	3	319	124	1	447	6	7	28	0	41	33	399	1	1	434	178	5	34	0	217	1139
16:45	14	297	116	1	428	3	7	40	1	51	16	381	0	0	397	208	1	32	0	241	1117
Total	36	1209	493	4	1742	34	29	117	2	182	130	1641	5	1	1777	753	23	175	1	952	4653
17:00	5	321	119	0	445	11	8	27	0	46	31	420	5	0	456	165	2	21	0	188	1135
17:15	10	340	112	0	462	14	14	23	0	51	32	398	1	0	431	103	1	17	2	123	1067
17:30	12	303	110	1	426	5	8	26	1	40	21	389	2	1	413	183	7	20	0	210	1089
17:45	13	260	107	0	380	12	13	30	0	55	58	413	6	0	477	168	6	10	0	184	1096
Total	40	1224	448	1	1713	42	43	106	1	192	142	1620	14	1	1777	619	16	68	2	705	4387
Grand Total	204	11457	2751	10	14422	230	169	485	10	894	1003	9650	114	8	10775	3663	188	2022	11	5884	31975
Apprch %	1.4	79.4	19.1	0.1		25.7	18.9	54.3	1.1		9.3	89.6	1.1	0.1		62.3	3.2	34.4	0.2		
Total %	0.6	35.8	8.6	0	45.1	0.7	0.5	1.5	0	2.8	3.1	30.2	0.4	0	33.7	11.5	0.6	6.3	0	18.4	



MINNESOTA DEPT OF TRANSPORTATION

TRAFFIC DATA COLLECTION - METRO

File Name : TH169A-3
 Site Code : 00000000
 Start Date : 5/3/2006
 Page No : 2

Start Time	TH 169 Southbound					MILLER RD/DAYTON RD Westbound					TH 169 Northbound					MILLER RD/DAYTON RD Eastbound					Int. Total
	LEFT	THRU	RIGHT	Peds	App. Total	LEFT	THRU	RIGHT	Peds	App. Total	LEFT	THRU	RIGHT	Peds	App. Total	LEFT	THRU	RIGHT	Peds	App. Total	
Peak Hour Analysis From 06:00 to 09:45 - Peak 1 of 1																					
Peak Hour for Entire Intersection Begins at 07:00																					
07:00	4	518	96	0	618	7	3	7	0	17	25	218	2	0	245	97	2	149	0	248	1128
07:15	4	539	82	0	625	8	8	19	0	35	30	287	4	0	321	130	6	183	1	320	1301
07:30	5	516	96	0	617	5	3	16	0	24	32	295	3	0	330	160	8	149	0	317	1288
07:45	4	510	95	0	609	7	9	12	0	28	29	313	6	0	348	171	11	136	0	318	1303
Total Volume	17	2083	369	0	2469	27	23	54	0	104	116	1113	15	0	1244	558	27	617	1	1203	5020
% App. Total	0.7	84.4	14.9	0		26	22.1	51.9	0		9.3	89.5	1.2	0		46.4	2.2	51.3	0.1		
PHF	.850	.966	.961	.000	.988	.844	.639	.711	.000	.743	.906	.889	.625	.000	.894	.816	.614	.843	.250	.940	.963

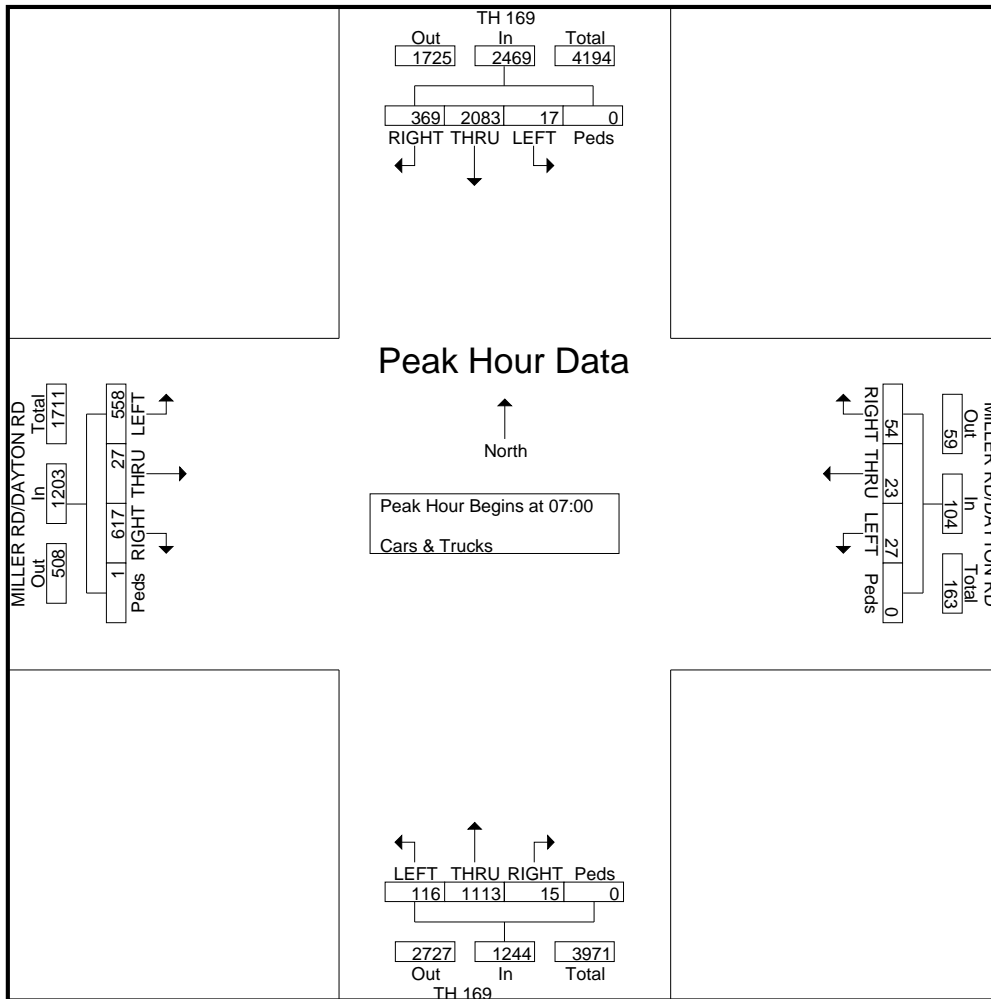



MINNESOTA DEPT OF TRANSPORTATION

TRAFFIC DATA COLLECTION - METRO

File Name : TH169A-3
 Site Code : 00000000
 Start Date : 5/3/2006
 Page No : 3

Start Time	TH 169 Southbound					MILLER RD/DAYTON RD Westbound					TH 169 Northbound					MILLER RD/DAYTON RD Eastbound					Int. Total
	LEFT	THRU	RIGHT	Peds	App. Total	LEFT	THRU	RIGHT	Peds	App. Total	LEFT	THRU	RIGHT	Peds	App. Total	LEFT	THRU	RIGHT	Peds	App. Total	
Peak Hour Analysis From 10:00 to 13:45 - Peak 1 of 1																					
Peak Hour for Entire Intersection Begins at 11:45																					
11:45	7	322	51	0	380	6	3	12	0	21	41	220	1	0	262	62	7	36	0	105	768
12:00	8	251	44	2	305	9	4	11	1	25	29	253	7	0	289	68	6	34	0	108	727
12:15	3	290	56	0	349	5	3	11	0	19	36	292	6	1	335	69	5	30	0	104	807
12:30	12	255	41	0	308	7	2	16	0	25	37	317	7	0	361	70	9	47	0	126	820
Total Volume	30	1118	192	2	1342	27	12	50	1	90	143	1082	21	1	1247	269	27	147	0	443	3122
% App. Total	2.2	83.3	14.3	0.1		30	13.3	55.6	1.1		11.5	86.8	1.7	0.1		60.7	6.1	33.2	0		
PHF	.625	.868	.857	.250	.883	.750	.750	.781	.250	.900	.872	.853	.750	.250	.864	.961	.750	.782	.000	.879	.952

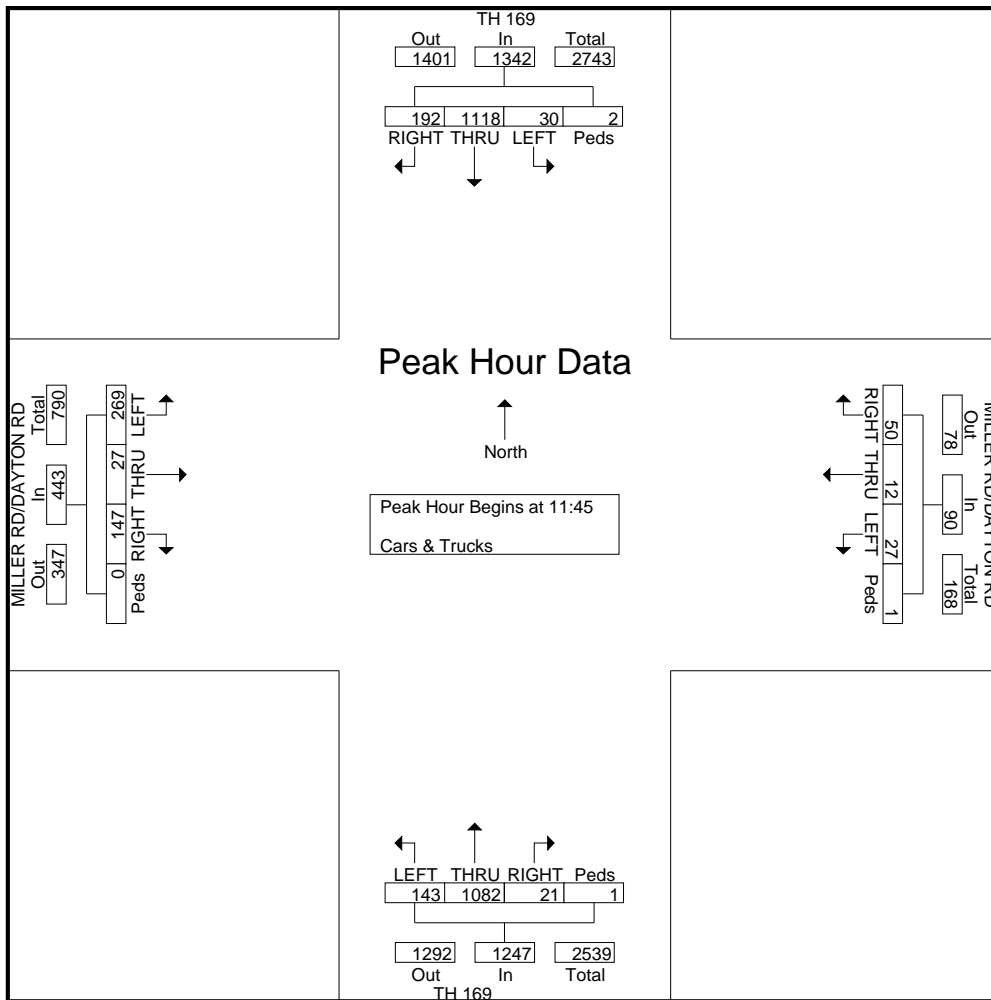



MINNESOTA DEPT OF TRANSPORTATION

TRAFFIC DATA COLLECTION - METRO

File Name : TH169A-3
 Site Code : 00000000
 Start Date : 5/3/2006
 Page No : 4

Start Time	TH 169 Southbound					MILLER RD/DAYTON RD Westbound					TH 169 Northbound					MILLER RD/DAYTON RD Eastbound					Int. Total
	LEFT	THRU	RIGHT	Peds	App. Total	LEFT	THRU	RIGHT	Peds	App. Total	LEFT	THRU	RIGHT	Peds	App. Total	LEFT	THRU	RIGHT	Peds	App. Total	
Peak Hour Analysis From 14:00 to 17:45 - Peak 1 of 1																					
Peak Hour for Entire Intersection Begins at 16:00																					
16:00	9	288	117	1	415	17	6	23	0	46	40	426	3	0	469	184	10	61	0	255	1185
16:15	10	305	136	1	452	8	9	26	1	44	41	435	1	0	477	183	7	48	1	239	1212
16:30	3	319	124	1	447	6	7	28	0	41	33	399	1	1	434	178	5	34	0	217	1139
16:45	14	297	116	1	428	3	7	40	1	51	16	381	0	0	397	208	1	32	0	241	1117
Total Volume	36	1209	493	4	1742	34	29	117	2	182	130	1641	5	1	1777	753	23	175	1	952	4653
% App. Total	2.1	69.4	28.3	0.2		18.7	15.9	64.3	1.1		7.3	92.3	0.3	0.1		79.1	2.4	18.4	0.1		
PHF	.643	.947	.906	1.000	.963	.500	.806	.731	.500	.892	.793	.943	.417	.250	.931	.905	.575	.717	.250	.933	.960

