

Alliant Engineering Inc Minneapolis, MN 55415

Prairie Center Drive at Viking Drive
Eden Prairie
data by: Alliant Engineering
TURN MOVEMENT COUNT

File Name : 15_Prairie Center Drive at Viking Drive
Site Code : 00000015
Start Date : 10/14/2009
Page No : 1

Groups Printed- Unshifted - Bank 1

Start Time	Prairie Center Drive Southbound				Viking Drive Westbound				Prairie Center Drive Northbound				Viking Drive Eastbound				Int. Total
	Left	Thru	Right	Peds	Left	Thru	Right	Peds	Left	Thru	Right	Peds	Left	Thru	Right	Peds	
06:30	24	26	2	0	2	0	1	0	5	77	40	0	0	12	2	0	191
06:45	34	44	1	0	5	1	4	0	7	107	74	0	2	14	6	1	300
Total	58	70	3	0	7	1	5	0	12	184	114	0	2	26	8	1	491
07:00	42	58	2	0	9	1	2	0	4	160	55	0	2	9	14	0	358
07:15	67	61	6	1	7	2	4	0	9	163	91	1	8	10	10	1	441
07:30	52	76	3	0	11	2	6	0	11	225	111	0	11	24	7	1	540
07:45	94	76	3	0	9	5	7	0	7	246	166	0	9	55	16	0	693
Total	255	271	14	1	36	10	19	0	31	794	423	1	30	98	47	2	2032
08:00	88	68	4	1	12	0	6	0	8	153	120	1	4	25	12	1	503
08:15	67	63	2	0	12	3	7	0	12	166	105	0	4	25	8	1	475
08:30	63	64	2	0	12	8	6	0	10	144	59	0	4	11	9	1	393
08:45	51	61	1	0	11	2	12	0	8	136	66	1	5	14	15	0	383
Total	269	256	9	1	47	13	31	0	38	599	350	2	17	75	44	3	1754
09:00	28	48	2	0	10	4	7	0	5	114	40	0	2	14	7	0	281
09:15	24	55	3	0	14	2	5	0	7	105	31	0	1	1	6	0	254
*** BREAK ***																	
Total	52	103	5	0	24	6	12	0	12	219	71	0	3	15	13	0	535
*** BREAK ***																	
10:30	7	73	1	0	25	7	9	0	6	77	5	0	2	2	9	0	223
10:45	13	60	0	0	19	1	13	0	5	90	20	0	2	7	8	0	238
Total	20	133	1	0	44	8	22	0	11	167	25	0	4	9	17	0	461
11:00	7	85	3	0	63	7	27	2	12	75	22	0	2	3	3	0	311
11:15	15	118	5	0	86	7	17	0	16	91	34	1	3	9	6	1	409
11:30	10	159	14	0	121	8	36	2	15	81	45	0	2	7	8	0	508
11:45	25	130	12	0	141	16	30	1	17	115	55	0	1	19	11	0	573
Total	57	492	34	0	411	38	110	5	60	362	156	1	8	38	28	1	1801
12:00	12	156	6	0	115	21	32	0	11	133	61	0	5	26	15	0	593
12:15	20	136	7	0	107	7	33	0	8	124	96	0	5	21	13	0	577
12:30	15	120	3	2	110	13	20	1	12	136	85	0	8	26	16	0	567
12:45	26	129	3	0	55	9	18	0	12	154	120	0	9	21	19	0	575
Total	73	541	19	2	387	50	103	1	43	547	362	0	27	94	63	0	2312
13:00	28	89	6	0	74	12	23	0	12	134	91	0	5	37	20	1	532
13:15	22	87	7	0	40	10	21	0	6	101	94	0	3	23	12	0	426
*** BREAK ***																	
Total	50	176	13	0	114	22	44	0	18	235	185	0	8	60	32	1	958
*** BREAK ***																	
14:30	5	99	1	0	44	5	24	0	6	97	32	0	2	6	6	0	327
14:45	11	78	4	4	26	3	24	0	10	92	23	0	1	4	6	0	286
Total	16	177	5	4	70	8	48	0	16	189	55	0	3	10	12	0	613
15:00	6	120	4	0	58	3	40	0	7	86	17	0	2	2	11	0	356
15:15	11	93	0	0	63	8	23	0	9	69	17	0	0	6	10	0	309
15:30	6	133	0	0	98	2	63	0	12	112	12	1	3	2	12	0	456
15:45	9	154	3	0	75	8	41	0	3	104	19	0	3	3	5	0	427
Total	32	500	7	0	294	21	167	0	31	371	65	1	8	13	38	0	1548
16:00	11	196	3	0	107	7	80	0	15	116	17	0	0	2	9	3	566
16:15	7	219	5	0	131	30	70	2	7	108	17	0	1	6	15	0	618
16:30	16	256	12	0	166	8	121	0	12	145	16	0	0	3	19	0	774
16:45	6	269	5	1	124	35	92	3	16	116	17	0	4	4	22	0	714
Total	40	940	25	1	528	80	363	5	50	485	67	0	5	15	65	3	2672

Alliant Engineering Inc Minneapolis, MN 55415

Prairie Center Drive at Viking Drive
Eden Prairie
data by: Alliant Engineering
TURN MOVEMENT COUNT

File Name : 15_Prairie Center Drive at Viking Drive
Site Code : 00000015
Start Date : 10/14/2009
Page No : 2

Groups Printed- Unshifted - Bank 1

Start Time	Prairie Center Drive Southbound				Viking Drive Westbound				Prairie Center Drive Northbound				Viking Drive Eastbound				Int. Total
	Left	Thru	Right	Peds	Left	Thru	Right	Peds	Left	Thru	Right	Peds	Left	Thru	Right	Peds	
17:00	13	297	6	0	242	10	139	0	11	119	27	0	2	3	22	0	891
17:15	14	295	12	0	139	9	95	0	17	121	22	0	0	6	20	0	750
17:30	4	236	12	0	93	8	49	0	18	104	9	0	3	2	17	0	555
17:45	9	192	13	0	81	12	48	0	10	101	15	0	3	5	19	0	508
Total	40	1020	43	0	555	39	331	0	56	445	73	0	8	16	78	0	2704
18:00	3	175	3	0	64	7	45	0	11	114	10	0	1	1	16	0	450
18:15	0	125	4	0	48	3	23	0	10	118	6	0	1	3	19	0	360
18:30	2	109	9	0	35	11	23	0	11	88	2	0	5	2	18	0	315
18:45	1	73	4	0	29	5	9	0	12	62	6	0	6	4	14	0	225
Total	6	482	20	0	176	26	100	0	44	382	24	0	13	10	67	0	1350
Grand Total	968	5161	198	9	2693	322	1355	11	422	4979	1970	5	136	479	512	11	19231
Apprch %	15.3	81.5	3.1	0.1	61.5	7.3	30.9	0.3	5.7	67.5	26.7	0.1	12	42.1	45	1	
Total %	5	26.8	1	0	14	1.7	7	0.1	2.2	25.9	10.2	0	0.7	2.5	2.7	0.1	
Unshifted	954	5110	194	9	2670	315	1338	11	420	4934	1952	5	136	472	506	11	19037
% Unshifted	98.6	99	98	100	99.1	97.8	98.7	100	99.5	99.1	99.1	100	100	98.5	98.8	100	99
Bank 1	14	51	4	0	23	7	17	0	2	45	18	0	0	7	6	0	194
% Bank 1	1.4	1	2	0	0.9	2.2	1.3	0	0.5	0.9	0.9	0	0	1.5	1.2	0	1

Alliant Engineering Inc Minneapolis, MN 55415

Prairie Center Drive at Viking Drive
Eden Prairie
data by: Alliant Engineering
TURN MOVEMENT COUNT

File Name : 15_Prairie Center Drive at Viking Drive
Site Code : 00000015
Start Date : 10/14/2009
Page No : 3

Start Time	Prairie Center Drive Southbound					Viking Drive Westbound					Prairie Center Drive Northbound					Viking Drive Eastbound					Int. Total
	Left	Thru	Right	Peds	App. Total	Left	Thru	Right	Peds	App. Total	Left	Thru	Right	Peds	App. Total	Left	Thru	Right	Peds	App. Total	
Peak Hour Analysis From 06:30 to 09:15 - Peak 1 of 1																					
Peak Hour for Entire Intersection Begins at 07:30																					
07:30	52	76	3	0	131	11	2	6	0	19	11	225	111	0	347	11	24	7	1	43	540
07:45	94	76	3	0	173	9	5	7	0	21	7	246	166	0	419	9	55	16	0	80	693
08:00	88	68	4	1	161	12	0	6	0	18	8	153	120	1	282	4	25	12	1	42	503
08:15	67	63	2	0	132	12	3	7	0	22	12	166	105	0	283	4	25	8	1	38	475
Total Volume	301	283	12	1	597	44	10	26	0	80	38	790	502	1	1331	28	129	43	3	203	2211
% App. Total	50.4	47.4	2	0.2		55	12.5	32.5	0		2.9	59.4	37.7	0.1		13.8	63.5	21.2	1.5		
PHF	.801	.931	.750	.250	.863	.917	.500	.929	.000	.909	.792	.803	.756	.250	.794	.636	.586	.672	.750	.634	.798

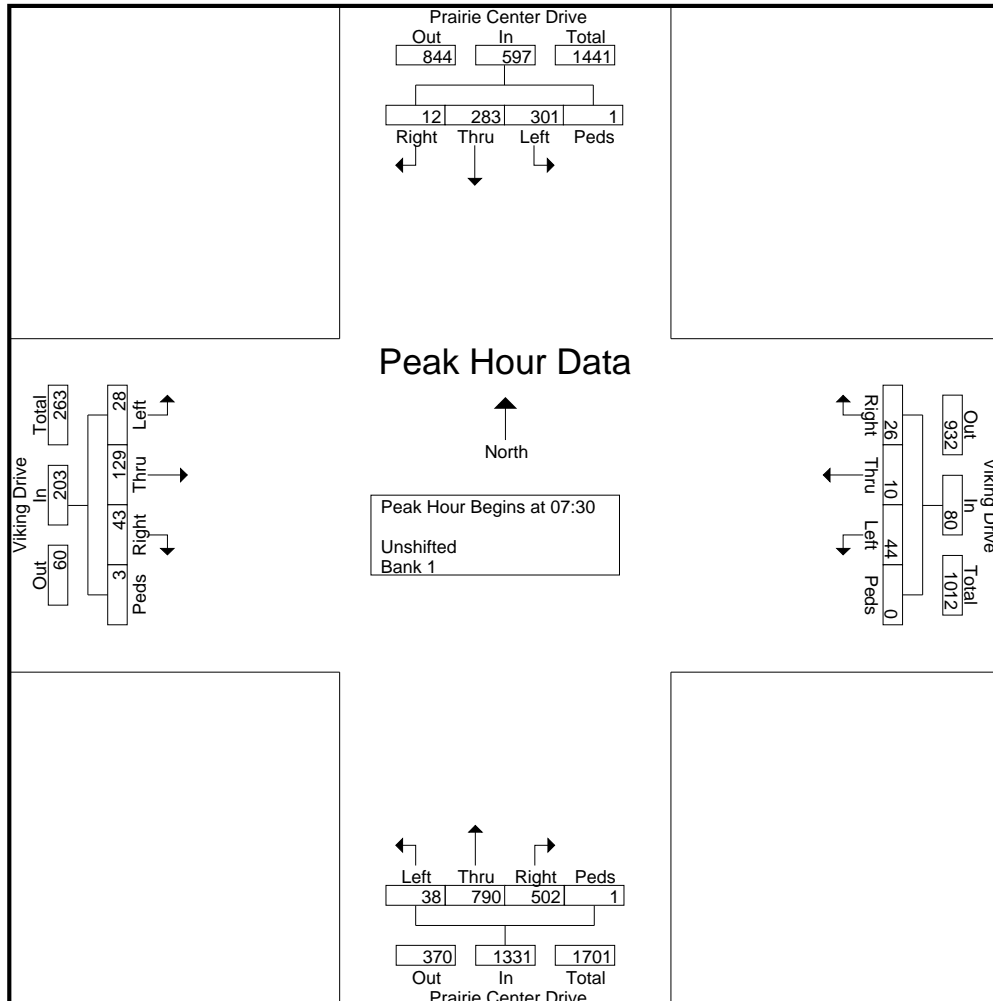

Alliant Engineering Inc Minneapolis, MN 55415

Prairie Center Drive at Viking Drive
Eden Prairie
data by: Alliant Engineering
TURN MOVEMENT COUNT

File Name : 15_Prairie Center Drive at Viking Drive
Site Code : 00000015
Start Date : 10/14/2009
Page No : 4

Start Time	Prairie Center Drive Southbound					Viking Drive Westbound					Prairie Center Drive Northbound					Viking Drive Eastbound					Int. Total
	Left	Thru	Right	Peds	App. Total	Left	Thru	Right	Peds	App. Total	Left	Thru	Right	Peds	App. Total	Left	Thru	Right	Peds	App. Total	
Peak Hour Analysis From 14:30 to 18:45 - Peak 1 of 1																					
Peak Hour for Entire Intersection Begins at 16:30																					
16:30	16	256	12	0	284	166	8	121	0	295	12	145	16	0	173	0	3	19	0	22	774
16:45	6	269	5	1	281	124	35	92	3	254	16	116	17	0	149	4	4	22	0	30	714
17:00	13	297	6	0	316	242	10	139	0	391	11	119	27	0	157	2	3	22	0	27	891
17:15	14	295	12	0	321	139	9	95	0	243	17	121	22	0	160	0	6	20	0	26	750
Total Volume	49	1117	35	1	1202	671	62	447	3	1183	56	501	82	0	639	6	16	83	0	105	3129
% App. Total	4.1	92.9	2.9	0.1		56.7	5.2	37.8	0.3		8.8	78.4	12.8	0		5.7	15.2	7.9	0		
PHF	.766	.940	.729	.250	.936	.693	.443	.804	.250	.756	.824	.864	.759	.000	.923	.375	.667	.943	.000	.875	.878

