



# MINNESOTA DEPT OF TRANSPORTATION

## TRAFFIC DATA COLLECTION - METRO

TH-52 AT CSAH-42, EAST RAMPS  
 Ref.Pt.: 115.573  
 JAMAR # 631 RE  
 TURN MOVEMENT COUNT

File Name : TH-52 AT CSAH-42 EAST RAMPS 2007  
 Site Code : 00000000  
 Start Date : 11/8/2007  
 Page No : 1

### Groups Printed- Cars & Trucks

Start Time	ramp to TH-52 NB Southbound				CSAH-42 Westbound				ramp from TH-52 NB Northbound				CSAH-42 Eastbound				Int. Total
	Left	Thru	Right	Peds	Left	Thru	Right	Peds	Left	Thru	Right	Peds	Left	Thru	Right	Peds	
06:00	0	0	0	0	0	17	3	0	7	0	1	0	48	14	0	0	90
06:15	0	0	0	0	0	27	3	0	24	0	4	0	80	18	0	0	156
06:30	0	0	0	0	0	40	0	0	27	2	7	0	92	27	1	0	196
06:45	0	0	0	0	0	40	2	0	29	0	5	0	102	31	0	0	209
Total	0	0	0	0	0	124	8	0	87	2	17	0	322	90	1	0	651
07:00	0	0	0	0	0	44	12	0	14	1	4	0	119	31	0	0	225
07:15	0	0	0	0	0	47	4	0	15	0	0	0	154	49	0	0	269
07:30	0	0	0	0	0	46	3	0	23	2	4	0	144	39	0	0	261
07:45	0	0	0	0	0	55	2	0	21	0	3	0	99	52	0	0	232
Total	0	0	0	0	0	192	21	0	73	3	11	0	516	171	0	0	987
08:00	0	0	0	0	0	37	1	0	27	0	3	0	75	38	0	0	181
08:15	0	0	0	0	0	33	5	0	11	0	1	0	82	39	0	0	171
08:30	0	0	0	0	0	31	5	0	23	0	2	0	71	38	0	0	170
08:45	0	0	0	0	0	35	6	0	21	0	3	0	37	42	0	0	144
Total	0	0	0	0	0	136	17	0	82	0	9	0	265	157	0	0	666
*** BREAK ***																	
15:00	0	0	0	0	0	32	6	0	16	1	2	0	38	52	0	0	147
15:15	0	0	0	0	0	33	9	0	14	0	5	0	34	44	0	0	139
15:30	0	0	0	0	0	36	9	0	22	0	6	0	54	55	0	0	182
15:45	0	0	0	0	0	40	5	0	18	0	8	0	68	51	0	0	190
Total	0	0	0	0	0	141	29	0	70	1	21	0	194	202	0	0	658
16:00	0	0	0	0	0	53	6	0	22	0	1	0	41	47	0	0	170
16:15	0	0	0	0	0	41	5	0	24	0	3	0	44	42	0	0	159
16:30	0	0	0	0	0	47	11	0	19	0	5	0	73	64	0	0	219
16:45	0	0	0	0	0	63	9	0	19	0	2	0	37	44	0	0	174
Total	0	0	0	0	0	204	31	0	84	0	11	0	195	197	0	0	722
17:00	0	0	0	0	0	41	7	0	25	0	6	0	51	32	0	0	162
17:15	0	0	0	0	0	45	6	0	23	0	2	0	38	39	0	0	153
17:30	0	0	0	0	0	41	3	0	20	0	1	0	45	38	0	0	148
17:45	0	0	0	0	0	21	0	0	19	1	1	0	35	42	0	0	119
Total	0	0	0	0	0	148	16	0	87	1	10	0	169	151	0	0	582
Grand Total	0	0	0	0	0	945	122	0	483	7	79	0	1661	968	1	0	4266
Apprch %	0	0	0	0	0	88.6	11.4	0	84.9	1.2	13.9	0	63.2	36.8	0	0	
Total %	0	0	0	0	0	22.2	2.9	0	11.3	0.2	1.9	0	38.9	22.7	0	0	



# MINNESOTA DEPT OF TRANSPORTATION

## TRAFFIC DATA COLLECTION - METRO

TH-52 AT CSAH-42, EAST RAMPS  
 Ref.Pt.: 115.573  
 JAMAR # 631 RE  
 TURN MOVEMENT COUNT

File Name : TH-52 AT CSAH-42 EAST RAMPS 2007  
 Site Code : 00000000  
 Start Date : 11/8/2007  
 Page No : 2

Start Time	ramp to TH-52 NB Southbound					CSAH-42 Westbound					ramp from TH-52 NB Northbound					CSAH-42 Eastbound					Int. Total
	Left	Thru	Right	Peds	App. Total	Left	Thru	Right	Peds	App. Total	Left	Thru	Right	Peds	App. Total	Left	Thru	Right	Peds	App. Total	
Peak Hour Analysis From 06:00 to 08:45 - Peak 1 of 1																					
Peak Hour for Entire Intersection Begins at 07:00																					
07:00	0	0	0	0	0	0	44	12	0	56	14	1	4	0	19	119	31	0	0	150	225
07:15	0	0	0	0	0	0	47	4	0	51	15	0	0	0	15	154	49	0	0	203	269
07:30	0	0	0	0	0	0	46	3	0	49	23	2	4	0	29	144	39	0	0	183	261
07:45	0	0	0	0	0	0	55	2	0	57	21	0	3	0	24	99	52	0	0	151	232
Total Volume	0	0	0	0	0	0	192	21	0	213	73	3	11	0	87	516	171	0	0	687	987
% App. Total																					
PHF	.000	.000	.000	.000	.000	.000	.873	.438	.000	.934	.793	.375	.688	.000	.750	.838	.822	.000	.000	.846	.917

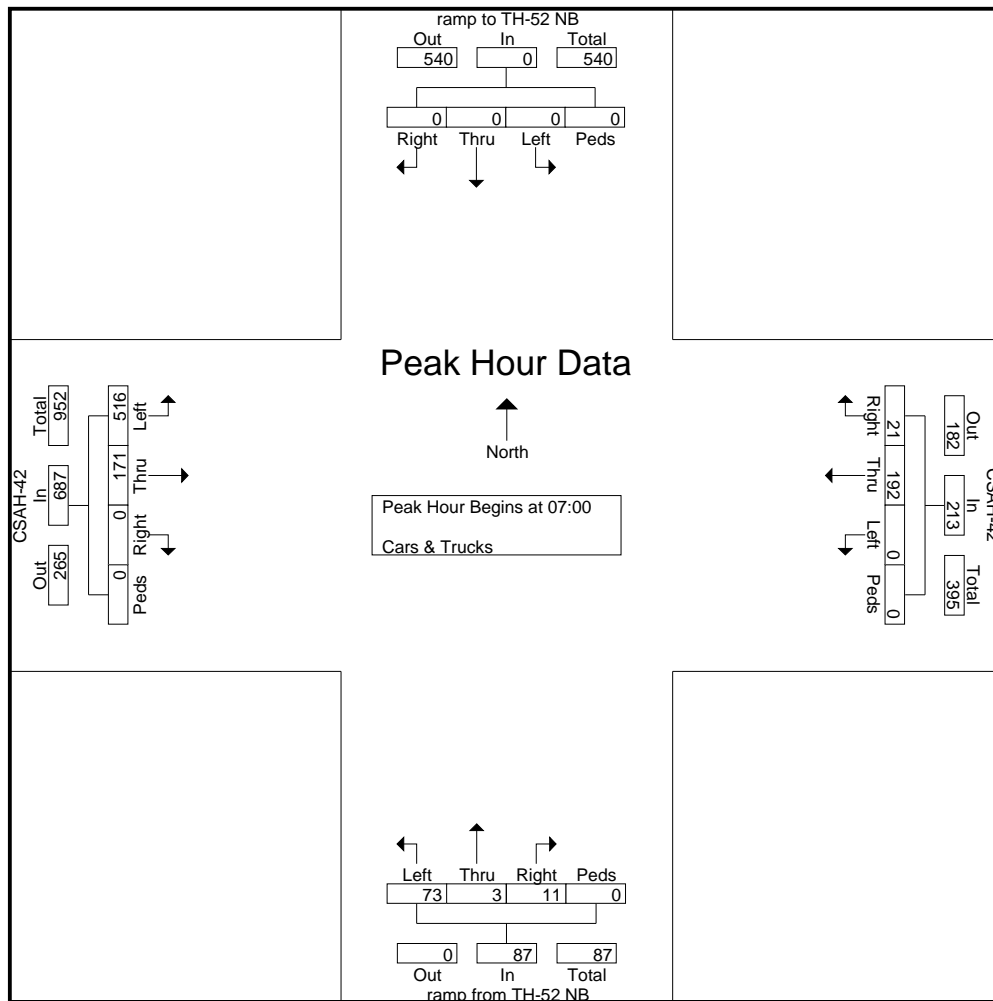



# MINNESOTA DEPT OF TRANSPORTATION

## TRAFFIC DATA COLLECTION - METRO

TH-52 AT CSAH-42, EAST RAMPS  
 Ref.Pt.: 115.573  
 JAMAR # 631 RE  
 TURN MOVEMENT COUNT

File Name : TH-52 AT CSAH-42 EAST RAMPS 2007  
 Site Code : 00000000  
 Start Date : 11/8/2007  
 Page No : 3

Start Time	ramp to TH-52 NB Southbound					CSAH-42 Westbound					ramp from TH-52 NB Northbound					CSAH-42 Eastbound					Int. Total
	Left	Thru	Right	Peds	App. Total	Left	Thru	Right	Peds	App. Total	Left	Thru	Right	Peds	App. Total	Left	Thru	Right	Peds	App. Total	
Peak Hour Analysis From 15:00 to 17:45 - Peak 1 of 1																					
Peak Hour for Entire Intersection Begins at 15:45																					
15:45	0	0	0	0	0	0	40	5	0	45	18	0	8	0	26	68	51	0	0	119	190
16:00	0	0	0	0	0	0	53	6	0	59	22	0	1	0	23	41	47	0	0	88	170
16:15	0	0	0	0	0	0	41	5	0	46	24	0	3	0	27	44	42	0	0	86	159
16:30	0	0	0	0	0	0	47	11	0	58	19	0	5	0	24	73	64	0	0	137	219
Total Volume	0	0	0	0	0	0	181	27	0	208	83	0	17	0	100	226	204	0	0	430	738
% App. Total																					
PHF	.000	.000	.000	.000	.000	.000	.854	.614	.000	.881	.865	.000	.531	.000	.926	.774	.797	.000	.000	.785	.842

