

MN Dept of Transportation

TRAFFIC DATA COLLECTION - Metro

TH-52 (NB) at Butler Ave, east ramps
 Ref.Pt.: 127.926
 video RE
 TURN MOVEMENT COUNT

File Name : TH-52 NB at Butler Ave EAST RAMPS 2014
 Site Code :
 Start Date : 12/4/2014
 Page No : 1

Groups Printed- Cars +

Start Time	ramp to TH-52 NB Southbound				Butler Ave Westbound				ramp from TH-52 NB Northbound				Butler Ave Eastbound				Int. Total
	Left	Thru	Right	Peds	Left	Thru	Right	Peds	Left	Thru	Right	Peds	Left	Thru	Right	Peds	
06:00	0	0	0	0	0	11	6	0	9	0	0	0	26	3	0	0	55
06:15	0	0	0	0	0	13	10	0	14	0	2	0	36	5	0	0	80
06:30	0	0	0	0	0	17	9	0	14	0	2	0	49	15	0	0	106
06:45	0	0	0	0	0	15	15	0	31	0	1	0	39	16	0	0	117
Total	0	0	0	0	0	56	40	0	68	0	5	0	150	39	0	0	358
07:00	0	0	0	0	0	21	15	0	24	0	3	0	41	7	0	0	111
07:15	0	0	0	0	0	23	14	0	37	0	5	0	54	11	0	0	144
07:30	0	0	0	0	0	26	8	0	42	0	4	0	59	22	0	0	161
07:45	0	0	0	0	0	25	17	0	38	0	4	0	51	16	0	0	151
Total	0	0	0	0	0	95	54	0	141	0	16	0	205	56	0	0	567
08:00	0	0	0	0	0	29	7	0	30	0	3	0	36	21	0	0	126
08:15	0	0	0	0	0	30	5	0	45	0	8	0	33	13	0	0	134
08:30	0	0	0	0	0	16	7	0	25	0	4	0	49	14	0	0	115
08:45	0	0	0	0	0	16	6	0	27	0	2	0	38	13	0	0	102
Total	0	0	0	0	0	91	25	0	127	0	17	0	156	61	0	0	477
*****BREAK*****																	
15:00	0	0	0	0	0	19	3	0	43	0	11	0	59	20	0	0	155
15:15	0	0	0	0	0	22	2	0	64	0	16	0	52	21	0	0	177
15:30	0	0	0	0	0	27	0	0	54	0	10	0	46	31	0	0	168
15:45	0	0	0	0	0	23	6	0	39	0	12	0	46	36	0	0	162
Total	0	0	0	0	0	91	11	0	200	0	49	0	203	108	0	0	662
16:00	0	0	0	0	0	24	6	0	45	0	8	0	37	34	0	0	154
16:15	0	0	0	0	0	24	7	0	53	0	9	0	35	35	0	0	163
16:30	0	0	0	0	0	29	4	0	44	0	10	0	40	24	0	0	151
16:45	0	0	0	0	0	16	5	0	65	1	14	0	22	23	0	0	146
Total	0	0	0	0	0	93	22	0	207	1	41	0	134	116	0	0	614
17:00	0	0	0	0	0	33	5	0	60	1	9	0	35	33	0	0	176
17:15	0	0	0	0	0	24	8	0	66	0	16	0	45	34	0	0	193
17:30	0	0	0	0	0	33	8	0	43	0	12	0	40	24	0	0	160
17:45	0	0	0	0	0	21	5	0	45	0	9	0	44	19	0	0	143
Total	0	0	0	0	0	111	26	0	214	1	46	0	164	110	0	0	672
Grand Total	0	0	0	0	0	537	178	0	957	2	174	0	1012	490	0	0	3350
Apprch %	0	0	0	0	0	75.1	24.9	0	84.5	0.2	15.4	0	67.4	32.6	0	0	
Total %	0	0	0	0	0	16	5.3	0	28.6	0.1	5.2	0	30.2	14.6	0	0	

MN Dept of Transportation

TRAFFIC DATA COLLECTION - Metro

TH-52 (NB) at Butler Ave, east ramps
 Ref.Pt.: 127.926
 video RE
 TURN MOVEMENT COUNT

File Name : TH-52 NB at Butler Ave EAST RAMPS 2014
 Site Code :
 Start Date : 12/4/2014
 Page No : 2

Start Time	ramp to TH-52 NB Southbound					Butler Ave Westbound					ramp from TH-52 NB Northbound					Butler Ave Eastbound					Int. Total
	Left	Thru	Right	Peds	App. Total	Left	Thru	Right	Peds	App. Total	Left	Thru	Right	Peds	App. Total	Left	Thru	Right	Peds	App. Total	
Peak Hour Analysis From 06:00 to 08:45 - Peak 1 of 1																					
Peak Hour for Entire Intersection Begins at 07:15																					
07:15	0	0	0	0	0	0	23	14	0	37	37	0	5	0	42	54	11	0	0	65	144
07:30	0	0	0	0	0	0	26	8	0	34	42	0	4	0	46	59	22	0	0	81	161
07:45	0	0	0	0	0	0	25	17	0	42	38	0	4	0	42	51	16	0	0	67	151
08:00	0	0	0	0	0	0	29	7	0	36	30	0	3	0	33	36	21	0	0	57	126
Total Volume	0	0	0	0	0	0	103	46	0	149	147	0	16	0	163	200	70	0	0	270	582
% App. Total	0	0	0	0	0	0	69.1	30.9	0		90.2	0	9.8	0		74.1	25.9	0	0		
PHF	.000	.000	.000	.000	.000	.000	.888	.676	.000	.887	.875	.000	.800	.000	.886	.847	.795	.000	.000	.833	.904

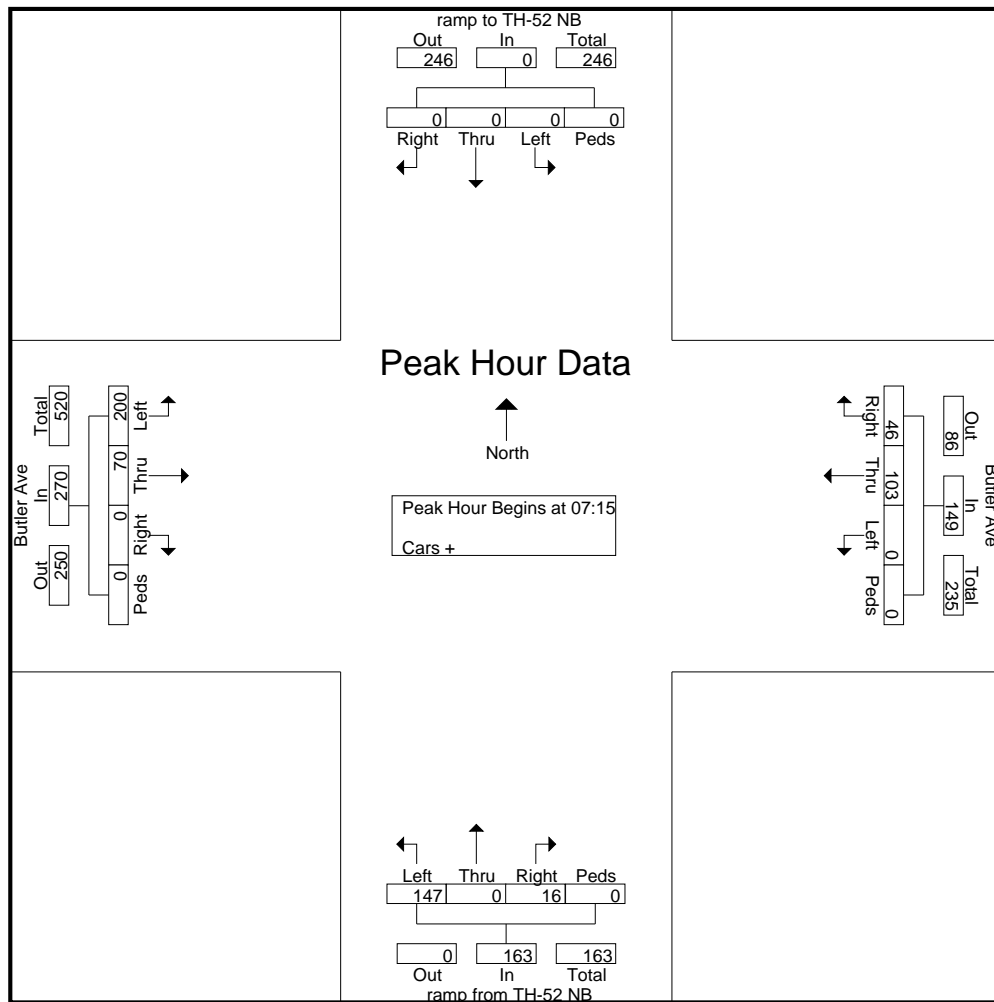

MN Dept of Transportation

TRAFFIC DATA COLLECTION - Metro

TH-52 (NB) at Butler Ave, east ramps
 Ref.Pt.: 127.926
 video RE
 TURN MOVEMENT COUNT

File Name : TH-52 NB at Butler Ave EAST RAMPS 2014
 Site Code :
 Start Date : 12/4/2014
 Page No : 3

Start Time	ramp to TH-52 NB Southbound					Butler Ave Westbound					ramp from TH-52 NB Northbound					Butler Ave Eastbound					Int. Total
	Left	Thru	Right	Peds	App. Total	Left	Thru	Right	Peds	App. Total	Left	Thru	Right	Peds	App. Total	Left	Thru	Right	Peds	App. Total	
Peak Hour Analysis From 15:00 to 17:45 - Peak 1 of 1																					
Peak Hour for Entire Intersection Begins at 16:45																					
16:45	0	0	0	0	0	0	16	5	0	21	65	1	14	0	80	22	23	0	0	45	146
17:00	0	0	0	0	0	0	33	5	0	38	60	1	9	0	70	35	33	0	0	68	176
17:15	0	0	0	0	0	0	24	8	0	32	66	0	16	0	82	45	34	0	0	79	193
17:30	0	0	0	0	0	0	33	8	0	41	43	0	12	0	55	40	24	0	0	64	160
Total Volume	0	0	0	0	0	0	106	26	0	132	234	2	51	0	287	142	114	0	0	256	675
% App. Total	0	0	0	0	0	0	80.3	19.7	0		81.5	0.7	17.8	0		55.5	44.5	0	0		
PHF	.000	.000	.000	.000	.000	.000	.803	.813	.000	.805	.886	.500	.797	.000	.875	.789	.838	.000	.000	.810	.874

