

MN Dept of Transportation

TRAFFIC DATA COLLECTION - Metro

TH-61 at Innovation Rd, EAST Ramps
 Ref.Pt.: 123.015
 video RE
 TURN MOVEMENT COUNT

File Name : TH-61 at Innovation Rd 2015
 Site Code :
 Start Date : 4/15/2015
 Page No : 1

Groups Printed- Cars +

Start Time	ramp to TH-61 NB Southbound				Innovation Rd S Westbound				ramp from TH-61 NB Northbound				Innovation Rd S Eastbound				Int. Total
	Left	Thru	Right	Peds	Left	Thru	Right	Peds	Left	Thru	Right	Peds	Left	Thru	Right	Peds	
06:00	0	0	0	0	0	24	17	0	14	0	14	0	6	9	0	0	84
06:15	0	0	0	0	0	52	38	0	18	0	22	0	6	13	0	0	149
06:30	0	0	0	0	0	61	39	0	31	0	33	0	4	17	0	0	185
06:45	0	0	0	0	0	46	34	0	19	0	29	0	3	24	0	0	155
Total	0	0	0	0	0	183	128	0	82	0	98	0	19	63	0	0	573
07:00	0	0	0	0	0	39	41	0	6	0	41	0	5	23	0	0	155
07:15	0	0	0	0	0	58	32	0	11	0	45	0	1	17	0	0	164
07:30	0	0	0	0	0	53	32	0	5	0	42	0	0	26	0	0	158
07:45	0	0	0	0	0	53	19	0	5	0	51	0	4	30	0	0	162
Total	0	0	0	0	0	203	124	0	27	0	179	0	10	96	0	0	639
08:00	0	0	0	0	0	53	15	0	2	0	25	0	5	25	0	0	125
08:15	0	0	0	0	0	36	21	0	4	0	26	0	1	20	0	0	108
08:30	0	0	0	0	0	47	19	0	4	1	43	0	3	23	0	0	140
08:45	0	0	0	0	0	47	17	0	3	1	35	0	5	13	0	0	121
Total	0	0	0	0	0	183	72	0	13	2	129	0	14	81	0	0	494
***** BREAK *****																	
15:00	0	0	0	0	0	54	18	0	4	1	40	0	33	61	0	0	211
15:15	0	0	0	0	0	81	24	0	5	2	46	0	34	52	0	0	244
15:30	0	0	0	0	0	74	23	0	6	2	48	0	31	63	0	0	247
15:45	0	0	0	0	0	60	31	0	8	0	53	0	13	53	0	0	218
Total	0	0	0	0	0	269	96	0	23	5	187	0	111	229	0	0	920
16:00	0	0	0	0	0	67	26	0	1	0	50	0	17	80	0	0	241
16:15	0	0	0	0	0	85	34	0	2	0	55	0	10	70	0	0	256
16:30	0	0	0	0	0	88	46	0	8	0	49	0	7	69	0	0	267
16:45	0	0	0	0	0	72	24	0	1	0	53	0	13	76	0	0	239
Total	0	0	0	0	0	312	130	0	12	0	207	0	47	295	0	0	1003
17:00	0	0	0	0	0	81	35	0	5	1	68	0	15	81	0	0	286
17:15	0	0	0	0	0	71	26	0	8	0	62	0	16	54	0	0	237
17:30	0	0	0	0	0	61	26	0	2	1	50	0	7	51	0	0	198
17:45	0	0	0	0	0	69	32	0	2	0	39	0	4	47	0	0	193
Total	0	0	0	0	0	282	119	0	17	2	219	0	42	233	0	0	914
Grand Total	0	0	0	0	0	1432	669	0	174	9	1019	0	243	997	0	0	4543
Apprch %	0	0	0	0	0	68.2	31.8	0	14.5	0.7	84.8	0	19.6	80.4	0	0	
Total %	0	0	0	0	0	31.5	14.7	0	3.8	0.2	22.4	0	5.3	21.9	0	0	

MN Dept of Transportation

TRAFFIC DATA COLLECTION - Metro

TH-61 at Innovation Rd, EAST Ramps
 Ref.Pt.: 123.015
 video RE
 TURN MOVEMENT COUNT

File Name : TH-61 at Innovation Rd 2015
 Site Code :
 Start Date : 4/15/2015
 Page No : 2

Start Time	ramp to TH-61 NB Southbound					Innovation Rd S Westbound					ramp from TH-61 NB Northbound					Innovation Rd S Eastbound					Int. Total
	Left	Thru	Right	Peds	App. Total	Left	Thru	Right	Peds	App. Total	Left	Thru	Right	Peds	App. Total	Left	Thru	Right	Peds	App. Total	
Peak Hour Analysis From 06:00 to 11:45 - Peak 1 of 1																					
Peak Hour for Entire Intersection Begins at 06:30																					
06:30	0	0	0	0	0	0	61	39	0	100	31	0	33	0	64	4	17	0	0	21	185
06:45	0	0	0	0	0	0	46	34	0	80	19	0	29	0	48	3	24	0	0	27	155
07:00	0	0	0	0	0	0	39	41	0	80	6	0	41	0	47	5	23	0	0	28	155
07:15	0	0	0	0	0	0	58	32	0	90	11	0	45	0	56	1	17	0	0	18	164
Total Volume	0	0	0	0	0	0	204	146	0	350	67	0	148	0	215	13	81	0	0	94	659
% App. Total	0	0	0	0	0	0	58.3	41.7	0		31.2	0	68.8	0		13.8	86.2	0	0		
PHF	.000	.000	.000	.000	.000	.000	.836	.890	.000	.875	.540	.000	.822	.000	.840	.650	.844	.000	.000	.839	.891

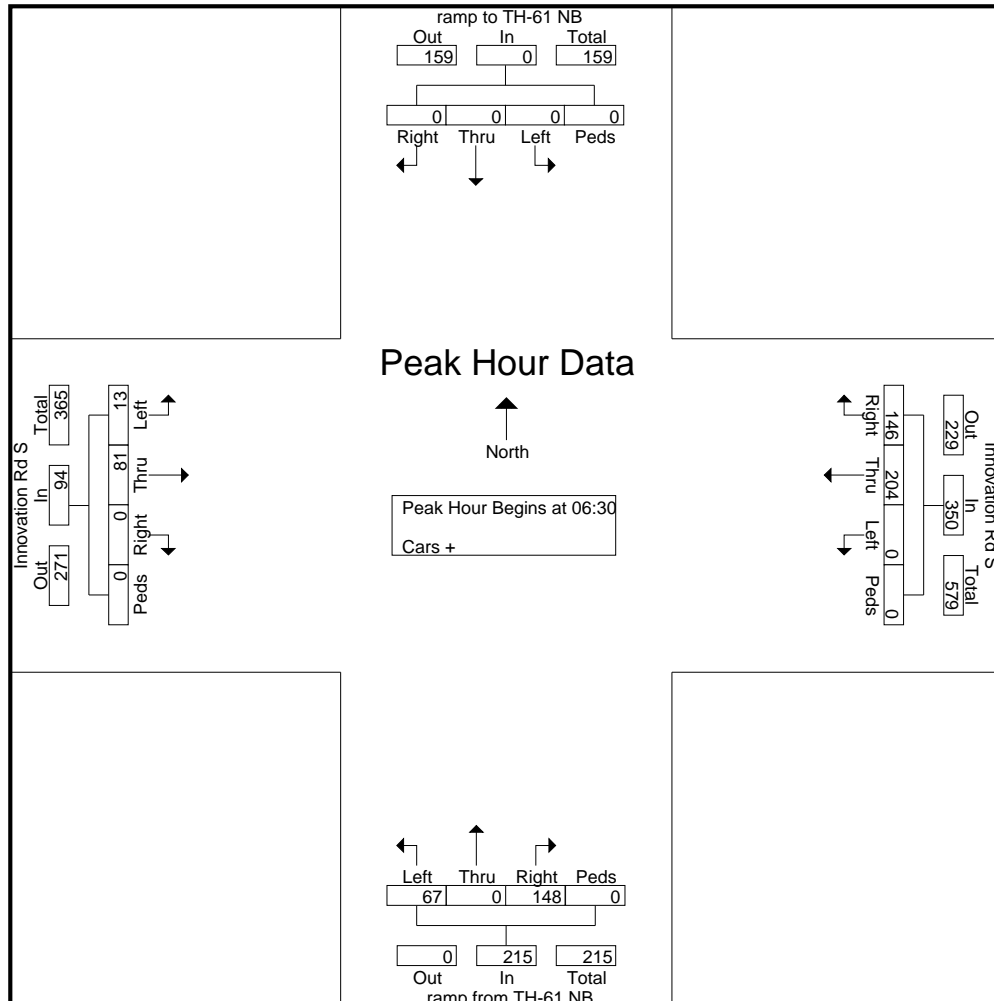

MN Dept of Transportation

TRAFFIC DATA COLLECTION - Metro

TH-61 at Innovation Rd, EAST Ramps
 Ref.Pt.: 123.015
 video RE
 TURN MOVEMENT COUNT

File Name : TH-61 at Innovation Rd 2015
 Site Code :
 Start Date : 4/15/2015
 Page No : 3

Start Time	ramp to TH-61 NB Southbound					Innovation Rd S Westbound					ramp from TH-61 NB Northbound					Innovation Rd S Eastbound					Int. Total
	Left	Thru	Right	Peds	App. Total	Left	Thru	Right	Peds	App. Total	Left	Thru	Right	Peds	App. Total	Left	Thru	Right	Peds	App. Total	
Peak Hour Analysis From 12:00 to 17:45 - Peak 1 of 1																					
Peak Hour for Entire Intersection Begins at 16:15																					
16:15	0	0	0	0	0	0	85	34	0	119	2	0	55	0	57	10	70	0	0	80	256
16:30	0	0	0	0	0	0	88	46	0	134	8	0	49	0	57	7	69	0	0	76	267
16:45	0	0	0	0	0	0	72	24	0	96	1	0	53	0	54	13	76	0	0	89	239
17:00	0	0	0	0	0	0	81	35	0	116	5	1	68	0	74	15	81	0	0	96	286
Total Volume	0	0	0	0	0	0	326	139	0	465	16	1	225	0	242	45	296	0	0	341	1048
% App. Total	0	0	0	0	0	0	70.1	29.9	0		6.6	0.4	93	0		13.2	86.8	0	0		
PHF	.000	.000	.000	.000	.000	.000	.926	.755	.000	.868	.500	.250	.827	.000	.818	.750	.914	.000	.000	.888	.916

