



# MINNESOTA DEPT OF TRANSPORTATION

## TRAFFIC DATA COLLECTION - METRO

TH-51/SNELLING AVE. AT Co.Rd.B  
 REF.PT.: 007.353  
 DATA COLLECTED BY TDI  
 TURN MOVEMENT COUNT

File Name : TH-51 SNELLING AVE AT CO RD B 2007  
 Site Code : 00198739  
 Start Date : 5/24/2007  
 Page No : 1

**Groups Printed- Unshifted**

Start Time	MN-51 / Snelling Ave. Southbound				County Rd B Westbound				MN-51 / Snelling Ave. Northbound				County Rd B Eastbound				Int. Total
	Left	Thru	Right	Peds	Left	Thru	Right	Peds	Left	Thru	Right	Peds	Left	Thru	Right	Peds	
06:00	5	89	17	0	8	8	7	0	2	74	3	3	2	3	4	0	225
06:15	8	154	19	2	10	6	14	1	4	65	10	0	6	4	8	1	312
06:30	8	214	21	0	10	24	16	0	4	103	4	1	6	5	7	0	423
06:45	26	200	27	0	18	33	13	0	8	136	14	1	18	14	8	1	517
Total	47	657	84	2	46	71	50	1	18	378	31	5	32	26	27	2	1477
07:00	13	247	27	0	16	24	23	0	8	157	10	1	6	17	1	1	551
07:15	18	271	58	1	15	57	24	0	15	174	21	0	11	10	6	0	681
07:30	22	265	38	2	36	84	20	1	11	217	14	1	14	24	8	0	757
07:45	26	338	64	0	21	92	25	0	36	233	24	2	18	30	3	1	913
Total	79	1121	187	3	88	257	92	1	70	781	69	4	49	81	18	2	2902
08:00	31	281	75	0	34	87	10	2	22	157	26	1	13	26	9	0	774
08:15	34	268	63	0	34	69	20	0	16	184	23	2	16	22	11	0	762
08:30	39	222	41	0	24	74	23	0	34	126	23	3	23	36	8	0	676
08:45	27	228	49	1	23	54	25	2	30	194	32	1	22	42	12	0	742
Total	131	999	228	1	115	284	78	4	102	661	104	7	74	126	40	0	2954
*** BREAK ***																	
11:00	88	146	31	1	34	53	56	1	16	159	39	0	26	51	25	0	726
11:15	87	161	36	5	34	36	55	0	20	200	59	2	18	60	18	0	791
11:30	106	147	29	0	29	56	69	0	33	177	56	2	33	72	11	0	820
11:45	103	191	73	0	60	60	60	1	29	226	57	2	31	52	21	0	966
Total	384	645	169	6	157	205	240	2	98	762	211	6	108	235	75	0	3303
12:00	120	158	40	0	58	59	100	0	38	193	57	2	32	71	30	0	958
12:15	96	201	43	1	53	52	70	0	39	264	54	2	38	72	16	0	1001
12:30	100	194	37	2	45	63	95	2	39	222	54	2	36	90	19	0	1000
12:45	94	189	40	0	60	64	90	0	34	241	50	3	46	79	16	0	1006
Total	410	742	160	3	216	238	355	2	150	920	215	9	152	312	81	0	3965
*** BREAK ***																	
15:00	72	190	49	1	33	65	64	2	32	289	38	1	33	62	16	0	947
15:15	80	194	27	2	40	74	66	1	34	311	39	2	39	102	19	0	1030
15:30	117	263	20	0	45	50	68	3	31	337	44	0	21	68	16	0	1083
15:45	103	219	29	0	40	42	59	2	30	305	57	6	34	139	30	1	1096
Total	372	866	125	3	158	231	257	8	127	1242	178	9	127	371	81	1	4156
16:00	73	225	39	1	60	53	72	5	24	325	40	2	35	124	29	0	1107
16:15	106	228	29	1	33	47	58	4	28	367	58	3	33	106	22	0	1123
16:30	78	236	40	2	42	59	73	6	18	352	63	0	24	152	28	0	1173
16:45	109	236	33	2	44	63	68	0	38	370	53	0	28	136	24	1	1205
Total	366	925	141	6	179	222	271	15	108	1414	214	5	120	518	103	1	4608
17:00	86	224	45	0	50	58	74	3	22	258	52	0	22	153	26	0	1073
17:15	108	288	36	6	42	74	78	2	24	253	44	4	25	148	24	0	1156
17:30	89	238	42	0	52	67	80	0	20	306	48	1	22	134	21	0	1120
17:45	119	235	45	1	45	71	75	3	29	241	41	7	26	161	18	0	1117
Total	402	985	168	7	189	270	307	8	95	1058	185	12	95	596	89	0	4466



**MINNESOTA DEPT OF TRANSPORTATION**  
 TRAFFIC DATA COLLECTION - METRO

TH-51/SNELLING AVE. AT Co.Rd.B  
 REF.PT.: 007.353  
 DATA COLLECTED BY TDI  
 TURN MOVEMENT COUNT

File Name : TH-51 SNELLING AVE AT CO RD B 2007  
 Site Code : 00198739  
 Start Date : 5/24/2007  
 Page No : 2

**Groups Printed- Unshifted**

	<b>MN-51 / Snelling Ave. Southbound</b>				<b>County Rd B Westbound</b>				<b>MN-51 / Snelling Ave. Northbound</b>				<b>County Rd B Eastbound</b>				<b>Int. Total</b>
	<b>Left</b>	<b>Thru</b>	<b>Right</b>	<b>Peds</b>	<b>Left</b>	<b>Thru</b>	<b>Right</b>	<b>Peds</b>	<b>Left</b>	<b>Thru</b>	<b>Right</b>	<b>Peds</b>	<b>Left</b>	<b>Thru</b>	<b>Right</b>	<b>Peds</b>	
Grand Total	2191	6940	1262	31	1148	1778	1650	41	768	7216	1207	57	757	2265	514	6	27831
Apprch %	21	66.6	12.1	0.3	24.9	38.5	35.7	0.9	8.3	78	13.1	0.6	21.4	63.9	14.5	0.2	
Total %	7.9	24.9	4.5	0.1	4.1	6.4	5.9	0.1	2.8	25.9	4.3	0.2	2.7	8.1	1.8	0	



# MINNESOTA DEPT OF TRANSPORTATION

## TRAFFIC DATA COLLECTION - METRO

TH-51/SNELLING AVE. AT Co.Rd.B  
 REF.PT.: 007.353  
 DATA COLLECTED BY TDI  
 TURN MOVEMENT COUNT

File Name : TH-51 SNELLING AVE AT CO RD B 2007  
 Site Code : 00198739  
 Start Date : 5/24/2007  
 Page No : 3

Start Time	MN-51 / Snelling Ave. Southbound					County Rd B Westbound					MN-51 / Snelling Ave. Northbound					County Rd B Eastbound					Int. Total
	Left	Thru	Right	Peds	App. Total	Left	Thru	Right	Peds	App. Total	Left	Thru	Right	Peds	App. Total	Left	Thru	Right	Peds	App. Total	
Peak Hour Analysis From 06:00 to 08:45 - Peak 1 of 1																					
Peak Hour for Entire Intersection Begins at 07:30																					
07:30	22	265	38	2	327	36	84	20	1	141	11	217	14	1	243	14	24	8	0	46	757
07:45	26	338	64	0	428	21	92	25	0	138	36	233	24	2	295	18	30	3	1	52	913
08:00	31	281	75	0	387	34	87	10	2	133	22	157	26	1	206	13	26	9	0	48	774
08:15	34	268	63	0	365	34	69	20	0	123	16	184	23	2	225	16	22	11	0	49	762
Total Volume	113	1152	240	2	1507	125	332	75	3	535	85	791	87	6	969	61	102	31	1	195	3206
% App. Total	7.5	76.4	15.9	0.1		23.4	62.1	14	0.6		8.8	81.6	9	0.6		31.3	52.3	15.9	0.5		
PHF	.831	.852	.800	.250	.880	.868	.902	.750	.375	.949	.590	.849	.837	.750	.821	.847	.850	.705	.250	.938	.878

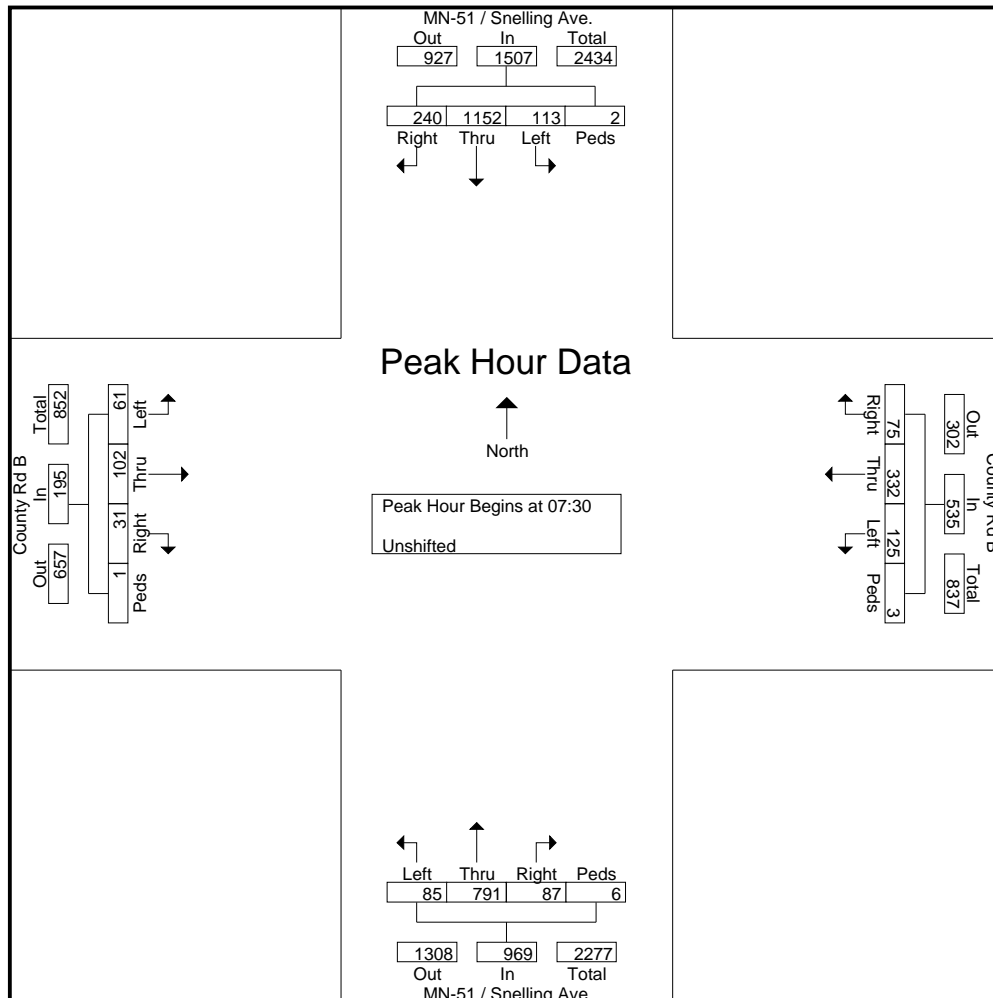



# MINNESOTA DEPT OF TRANSPORTATION

## TRAFFIC DATA COLLECTION - METRO

TH-51/SNELLING AVE. AT Co.Rd.B  
 REF.PT.: 007.353  
 DATA COLLECTED BY TDI  
 TURN MOVEMENT COUNT

File Name : TH-51 SNELLING AVE AT CO RD B 2007  
 Site Code : 00198739  
 Start Date : 5/24/2007  
 Page No : 4

Start Time	MN-51 / Snelling Ave. Southbound					County Rd B Westbound					MN-51 / Snelling Ave. Northbound					County Rd B Eastbound					Int. Total
	Left	Thru	Right	Peds	App. Total	Left	Thru	Right	Peds	App. Total	Left	Thru	Right	Peds	App. Total	Left	Thru	Right	Peds	App. Total	
Peak Hour Analysis From 15:00 to 17:45 - Peak 1 of 1																					
Peak Hour for Entire Intersection Begins at 16:00																					
16:00	73	225	39	1	338	60	53	72	5	190	24	325	40	2	391	35	124	29	0	188	1107
16:15	106	228	29	1	364	33	47	58	4	142	28	367	58	3	456	33	106	22	0	161	1123
16:30	78	236	40	2	356	42	59	73	6	180	18	352	63	0	433	24	152	28	0	204	1173
16:45	109	236	33	2	380	44	63	68	0	175	38	370	53	0	461	28	136	24	1	189	1205
Total Volume	366	925	141	6	1438	179	222	271	15	687	108	1414	214	5	1741	120	518	103	1	742	4608
% App. Total	25.5	64.3	9.8	0.4		26.1	32.3	39.4	2.2		6.2	81.2	12.3	0.3		16.2	69.8	13.9	0.1		
PHF	.839	.980	.881	.750	.946	.746	.881	.928	.625	.904	.711	.955	.849	.417	.944	.857	.852	.888	.250	.909	.956

