



MINNESOTA DEPT OF TRANSPORTATION

TRAFFIC DATA COLLECTION - METRO

Location: TH-52 at TH-50, east ramps
 Ref.Pt.: 105.686
 JAMAR #D4-3365 JI
 TURN MOVEMENT COUNT

File Name : TH-52 at TH-50 east ramps 2013
 Site Code : 00005052
 Start Date : 8/14/2013
 Page No : 1

Groups Printed- Cars & Trucks

Start Time	ramp to TH-52 NB Southbound				TH-50 / 240th St E Westbound				ramp from TH-52 NB Northbound				TH-50 / 240th St E Eastbound				Int. Total
	Right	Thru	Left	Peds	Right	Thru	Left	Peds	Right	Thru	Left	Peds	Right	Thru	Left	Peds	
06:15	0	0	0	0	45	16	0	0	1	1	19	0	0	36	31	0	149
06:30	0	0	0	0	50	19	0	0	3	0	12	0	0	23	24	0	131
06:45	0	0	0	0	33	13	0	3	0	0	8	0	0	31	40	0	128
Total	0	0	0	0	128	48	0	3	4	1	39	0	0	90	95	0	408
07:00	0	0	0	0	45	17	0	0	1	0	15	0	0	42	41	0	161
07:15	0	0	0	0	41	11	0	0	0	0	15	0	0	42	30	0	139
07:30	0	0	0	0	28	21	0	0	2	0	12	0	0	43	42	0	148
07:45	0	0	0	0	29	15	0	0	1	1	11	0	0	32	38	0	127
Total	0	0	0	0	143	64	0	0	4	1	53	0	0	159	151	0	575
08:00	0	0	0	0	38	10	0	0	0	0	6	0	0	38	22	0	114
08:15	0	0	0	0	18	7	0	0	1	0	6	0	0	33	20	0	85
08:30	0	0	0	0	29	25	0	0	1	0	15	0	0	36	13	0	119
08:45	0	0	0	0	34	15	0	0	0	0	5	0	0	23	13	0	90
Total	0	0	0	0	119	57	0	0	2	0	32	0	0	130	68	0	408
***** BREAK *****																	
15:00	0	0	0	0	22	23	0	0	1	0	18	0	0	47	12	0	123
15:15	0	0	0	0	35	22	0	0	2	0	14	0	0	27	11	0	111
15:30	0	0	0	0	39	32	0	0	4	0	13	0	0	57	20	0	165
15:45	0	0	0	0	33	21	0	0	3	1	14	0	0	57	8	0	137
Total	0	0	0	0	129	98	0	0	10	1	59	0	0	188	51	0	536
16:00	0	0	0	0	32	18	0	0	4	1	21	0	0	55	22	0	153
16:15	0	0	0	0	28	18	0	0	0	0	19	0	0	67	11	0	143
16:30	0	0	0	0	26	25	0	0	5	0	19	0	0	50	14	0	139
16:45	0	0	0	0	38	28	0	0	1	0	25	0	0	69	19	0	180
Total	0	0	0	0	124	89	0	0	10	1	84	0	0	241	66	0	615
17:00	0	0	0	0	28	30	0	0	3	1	27	0	0	70	30	0	189
17:15	0	0	0	0	22	29	0	0	2	0	11	0	0	67	17	0	148
17:30	0	0	0	0	37	26	0	0	1	0	13	0	0	63	13	0	153
17:45	0	0	0	0	25	18	0	0	6	0	16	0	0	71	11	0	147
Total	0	0	0	0	112	103	0	0	12	1	67	0	0	271	71	0	637
Grand Total	0	0	0	0	755	459	0	3	42	5	334	0	0	1079	502	0	3179
Apprch %	0	0	0	0	62	37.7	0	0.2	11	1.3	87.7	0	0	68.2	31.8	0	
Total %	0	0	0	0	23.7	14.4	0	0.1	1.3	0.2	10.5	0	0	33.9	15.8	0	



MINNESOTA DEPT OF TRANSPORTATION

TRAFFIC DATA COLLECTION - METRO

Location: TH-52 at TH-50, east ramps
 Ref.Pt.: 105.686
 JAMAR #D4-3365 JI
 TURN MOVEMENT COUNT

File Name : TH-52 at TH-50 east ramps 2013
 Site Code : 00005052
 Start Date : 8/14/2013
 Page No : 2

Start Time	ramp to TH-52 NB Southbound					TH-50 / 240th St E Westbound					ramp from TH-52 NB Northbound					TH-50 / 240th St E Eastbound					Int. Total
	Right	Thru	Left	Peds	App. Total	Right	Thru	Left	Peds	App. Total	Right	Thru	Left	Peds	App. Total	Right	Thru	Left	Peds	App. Total	
Peak Hour Analysis From 06:15 to 11:45 - Peak 1 of 1																					
Peak Hour for Entire Intersection Begins at 06:45																					
06:45	0	0	0	0	0	33	13	0	3	49	0	0	8	0	8	0	31	40	0	71	128
07:00	0	0	0	0	0	45	17	0	0	62	1	0	15	0	16	0	42	41	0	83	161
07:15	0	0	0	0	0	41	11	0	0	52	0	0	15	0	15	0	42	30	0	72	139
07:30	0	0	0	0	0	28	21	0	0	49	2	0	12	0	14	0	43	42	0	85	148
Total Volume	0	0	0	0	0	147	62	0	3	212	3	0	50	0	53	0	158	153	0	311	576
% App. Total	0	0	0	0	0	69.3	29.2	0	1.4		5.7	0	94.3	0		0	50.8	49.2	0		
PHF	.000	.000	.000	.000	.000	.817	.738	.000	.250	.855	.375	.000	.833	.000	.828	.000	.919	.911	.000	.915	.894

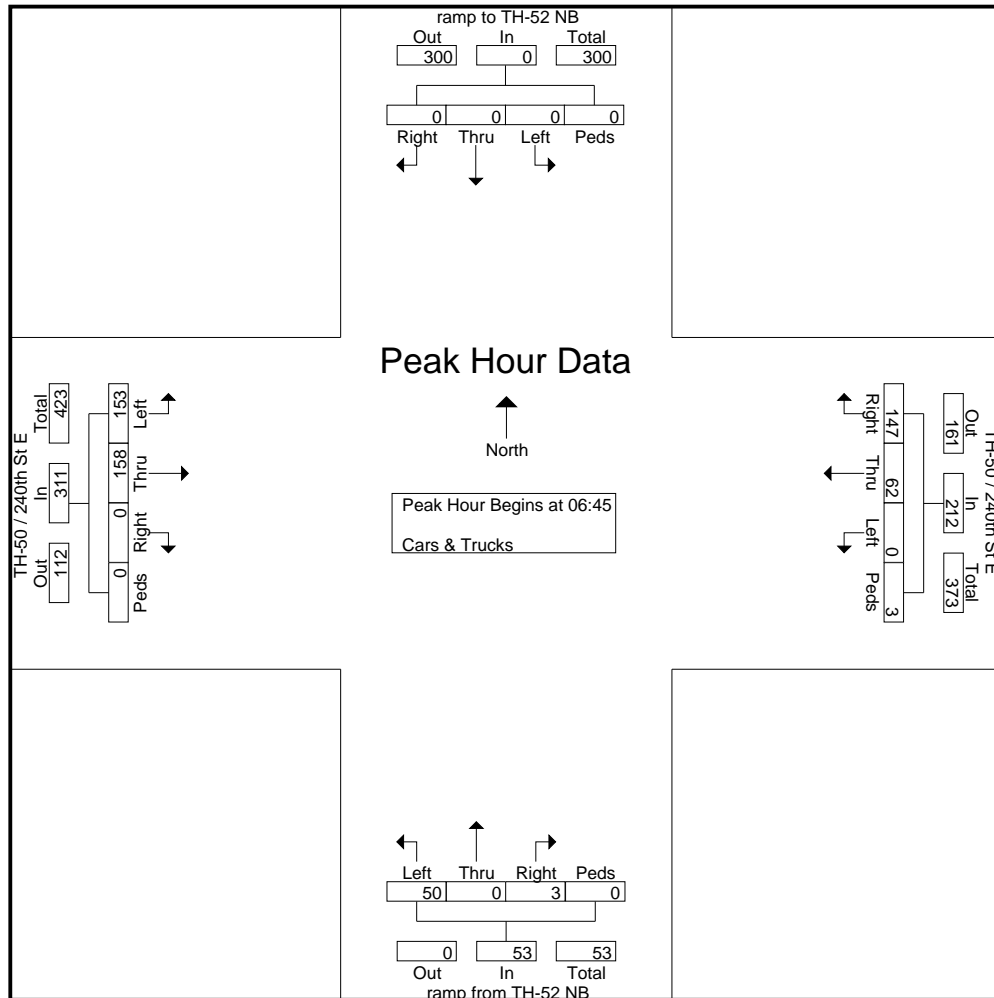



MINNESOTA DEPT OF TRANSPORTATION

TRAFFIC DATA COLLECTION - METRO

Location: TH-52 at TH-50, east ramps
 Ref.Pt.: 105.686
 JAMAR #D4-3365 JI
 TURN MOVEMENT COUNT

File Name : TH-52 at TH-50 east ramps 2013
 Site Code : 00005052
 Start Date : 8/14/2013
 Page No : 3

Start Time	ramp to TH-52 NB Southbound					TH-50 / 240th St E Westbound					ramp from TH-52 NB Northbound					TH-50 / 240th St E Eastbound					Int. Total
	Rig ht	Thr u	Left	Ped s	App. Total	Rig ht	Thr u	Left	Ped s	App. Total	Right	Thr u	Left	Peds	App. Total	Right	Thr u	Left	Peds	App. Total	
16:45	0	0	0	0	0	38	28	0	0	66	1	0	25	0	26	0	69	19	0	88	180
17:00	0	0	0	0	0	28	30	0	0	58	3	1	27	0	31	0	70	30	0	100	189
17:15	0	0	0	0	0	22	29	0	0	51	2	0	11	0	13	0	67	17	0	84	148
17:30	0	0	0	0	0	37	26	0	0	63	1	0	13	0	14	0	63	13	0	76	153
Total Volume	0	0	0	0	0	125	113	0	0	238	7	1	76	0	84	0	269	79	0	348	670
% App. Total	0	0	0	0	0	52.5	47.5	0	0	0	8.3	1.2	90.5	0	0	0	77.3	22.7	0	0	
PHF	.000	.000	.000	.000	.000	.822	.942	.000	.000	.902	.583	.250	.704	.000	.677	.000	.961	.658	.000	.870	.886

Peak Hour Analysis From 12:00 to 17:45 - Peak 1 of 1
 Peak Hour for Entire Intersection Begins at 16:45

