



MINNESOTA DEPT OF TRANSPORTATION

TRAFFIC DATA COLLECTION - METRO

Counted By: Ivan & Linda
 Day of the Week: Tuesday
 Location: TH 55 & Pinto Dr
 Project #: 5764

File Name : TH 55 @ PINTO DRIVE 2006
 Site Code : 07250219
 Start Date : 7/25/2006
 Page No : 1

Groups Printed- Unshifted

Start Time	Pinto Dr Southbound					TH 55 Westbound					Pinto Dr/Road Closed Northbound					TH 55 Eastbound					Int. Total
	Left	Thru	Right	Peds	App. Total	Left	Thru	Right	Peds	App. Total	Left	Thru	Right	Peds	App. Total	Left	Thru	Right	Peds	App. Total	
06:00	99	2	17	0	118	1	40	22	1	64	0	0	0	0	0	15	268	0	0	283	465
06:15	161	0	28	0	189	1	71	15	0	87	0	0	0	0	0	12	335	0	0	347	623
06:30	181	0	39	0	220	0	99	23	0	122	0	0	0	0	0	5	335	0	0	340	682
06:45	153	0	41	0	194	0	124	25	0	149	0	0	3	0	3	21	313	0	0	334	680
Total	594	2	125	0	721	2	334	85	1	422	0	0	3	0	3	53	1251	0	0	1304	2450
07:00	173	0	34	0	207	3	98	28	0	129	0	0	0	0	0	16	278	0	0	294	630
07:15	170	0	29	0	199	3	127	31	0	161	0	0	0	0	0	23	309	0	0	332	692
07:30	160	0	31	0	191	1	134	32	0	167	0	0	0	0	0	21	311	0	0	332	690
07:45	151	0	63	0	214	2	101	47	0	150	0	0	0	0	0	20	263	0	0	283	647
Total	654	0	157	0	811	9	460	138	0	607	0	0	0	0	0	80	1161	0	0	1241	2659
08:00	138	0	35	0	173	2	108	44	0	154	0	0	0	0	0	22	234	0	0	256	583
08:15	125	0	25	0	150	4	112	41	0	157	0	0	0	0	0	7	249	0	0	256	563
08:30	100	0	27	0	127	2	105	34	0	141	0	0	0	0	0	22	180	1	0	203	471
08:45	105	0	41	0	146	1	97	38	0	136	1	0	0	0	1	19	154	0	0	173	456
Total	468	0	128	0	596	9	422	157	0	588	1	0	0	0	1	70	817	1	0	888	2073
11:00	59	0	13	0	72	1	91	38	1	131	0	0	2	0	2	13	124	1	0	138	343
11:15	55	0	13	0	68	4	112	52	0	168	0	0	0	0	0	14	102	0	0	116	352
11:30	72	0	10	0	82	3	100	55	0	158	0	0	0	0	0	19	124	0	0	143	383
11:45	68	0	24	0	92	4	103	49	0	156	0	0	0	0	0	28	117	0	0	145	393
Total	254	0	60	0	314	12	406	194	1	613	0	0	2	0	2	74	467	1	0	542	1471
12:00	65	0	28	0	93	3	106	67	0	176	0	0	0	0	0	20	140	0	0	160	429
12:15	69	0	20	0	89	3	108	55	0	166	0	0	0	0	0	29	144	1	0	174	429
12:30	61	0	40	0	101	6	121	54	0	181	0	0	0	0	0	18	147	2	0	167	449
12:45	70	0	22	0	92	5	129	78	0	212	1	0	1	0	2	20	116	0	0	136	442
Total	265	0	110	0	375	17	464	254	0	735	1	0	1	0	2	87	547	3	0	637	1749
15:00	44	0	25	0	69	1	232	70	0	303	1	0	0	0	1	27	104	1	0	132	505
15:15	51	0	30	0	81	4	259	85	0	348	0	0	0	0	0	16	97	0	0	113	542
15:30	43	1	20	0	64	2	276	124	0	402	0	0	0	0	0	52	147	0	0	199	665
15:45	57	0	22	0	79	4	266	119	0	389	0	0	0	0	0	33	127	0	0	160	628
Total	195	1	97	0	293	11	1033	398	0	1442	1	0	0	0	1	128	475	1	0	604	2340
16:00	64	0	30	0	94	3	320	158	0	481	0	0	0	0	0	24	138	0	0	162	737
16:15	51	0	26	0	77	2	258	155	0	415	0	0	0	0	0	28	103	0	0	131	623
16:30	61	0	25	0	86	4	276	141	0	421	0	0	0	0	0	39	153	0	0	192	699
16:45	54	0	24	0	78	1	286	163	0	450	3	0	0	0	3	27	130	0	0	157	688
Total	230	0	105	0	335	10	1140	617	0	1767	3	0	0	0	3	118	524	0	0	642	2747
17:00	70	0	24	0	94	2	323	151	0	476	0	0	0	0	0	46	135	1	0	182	752
17:15	45	0	34	0	79	3	303	160	0	466	0	0	0	0	0	34	142	1	0	177	722
17:30	61	0	20	0	81	3	274	128	0	405	0	0	0	0	0	20	107	0	0	127	613
17:45	61	0	21	0	82	9	250	105	0	364	0	0	0	0	0	23	110	0	0	133	579
Total	237	0	99	0	336	17	1150	544	0	1711	0	0	0	0	0	123	494	2	0	619	2666
Grand Total	2897	3	881	0	3781	87	5409	2387	2	7885	6	0	6	0	12	733	5736	8	0	6477	18155
Apprch %	76.6	0.1	23.3	0		1.1	68.6	30.3	0		50	0	50	0		11.3	88.6	0.1	0		
Total %	16	0	4.9	0	20.8	0.5	29.8	13.1	0	43.4	0	0	0	0	0.1	4	31.6	0	0	35.7	



MINNESOTA DEPT OF TRANSPORTATION

TRAFFIC DATA COLLECTION - METRO

File Name : TH 55 @ PINTO DRIVE 2006
 Site Code : 07250219
 Start Date : 7/25/2006
 Page No : 2

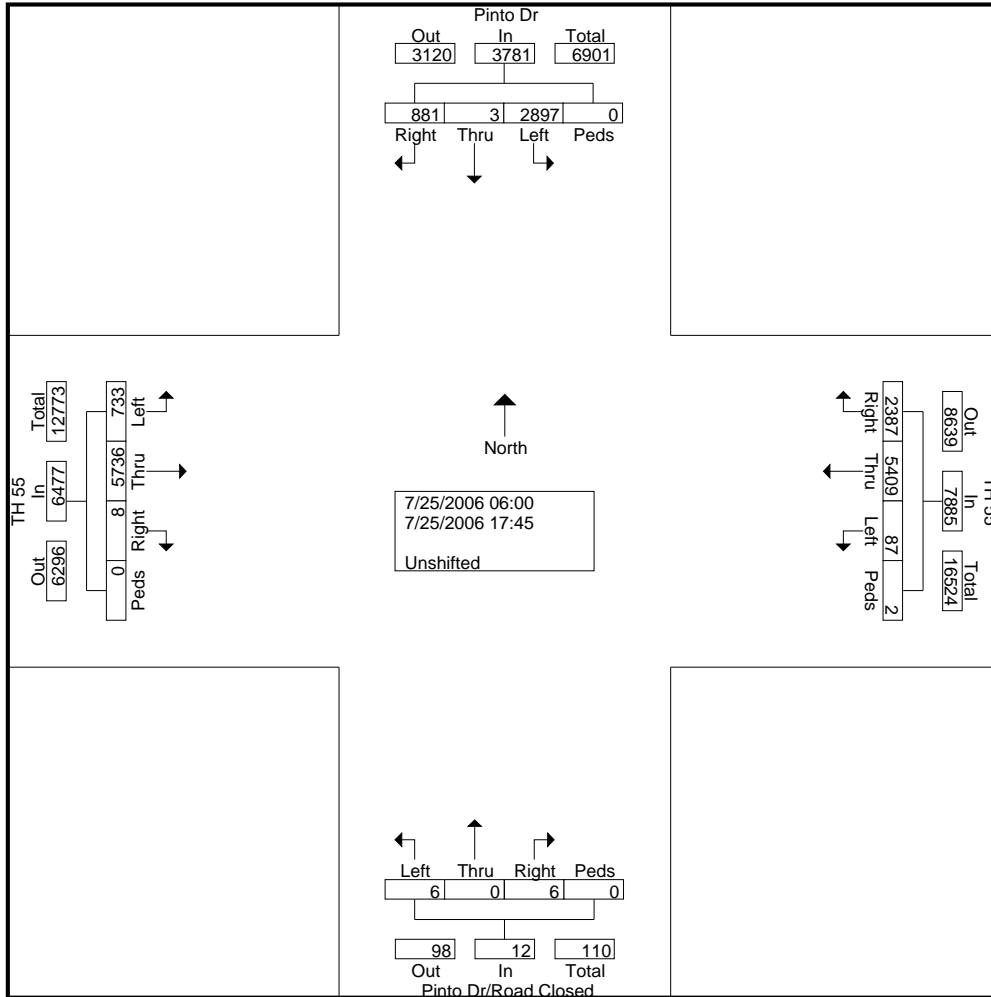



MINNESOTA DEPT OF TRANSPORTATION

TRAFFIC DATA COLLECTION - METRO

File Name : TH 55 @ PINTO DRIVE 2006
 Site Code : 07250219
 Start Date : 7/25/2006
 Page No : 3

Start Time	Pinto Dr Southbound					TH 55 Westbound					Pinto Dr/Road Closed Northbound					TH 55 Eastbound					Int. Total
	Left	Thru	Right	Peds	App. Total	Left	Thru	Right	Peds	App. Total	Left	Thru	Right	Peds	App. Total	Left	Thru	Right	Peds	App. Total	
Peak Hour Analysis From 06:00 to 09:45 - Peak 1 of 1																					
Peak Hour for Entire Intersection Begins at 06:45																					
06:45	153	0	41	0	194	0	124	25	0	149	0	0	3	0	3	21	313	0	0	334	680
07:00	173	0	34	0	207	3	98	28	0	129	0	0	0	0	0	16	278	0	0	294	630
07:15	170	0	29	0	199	3	127	31	0	161	0	0	0	0	0	23	309	0	0	332	692
07:30	160	0	31	0	191	1	134	32	0	167	0	0	0	0	0	21	311	0	0	332	690
Total Volume	656	0	135	0	791	7	483	116	0	606	0	0	3	0	3	81	1211	0	0	1292	2692
% App. Total	82.9	0	17.1	0		1.2	79.7	19.1	0		0	0	100	0		6.3	93.7	0	0		
PHF	.948	.000	.823	.000	.955	.583	.901	.906	.000	.907	.000	.000	.250	.000	.250	.880	.967	.000	.000	.967	.973

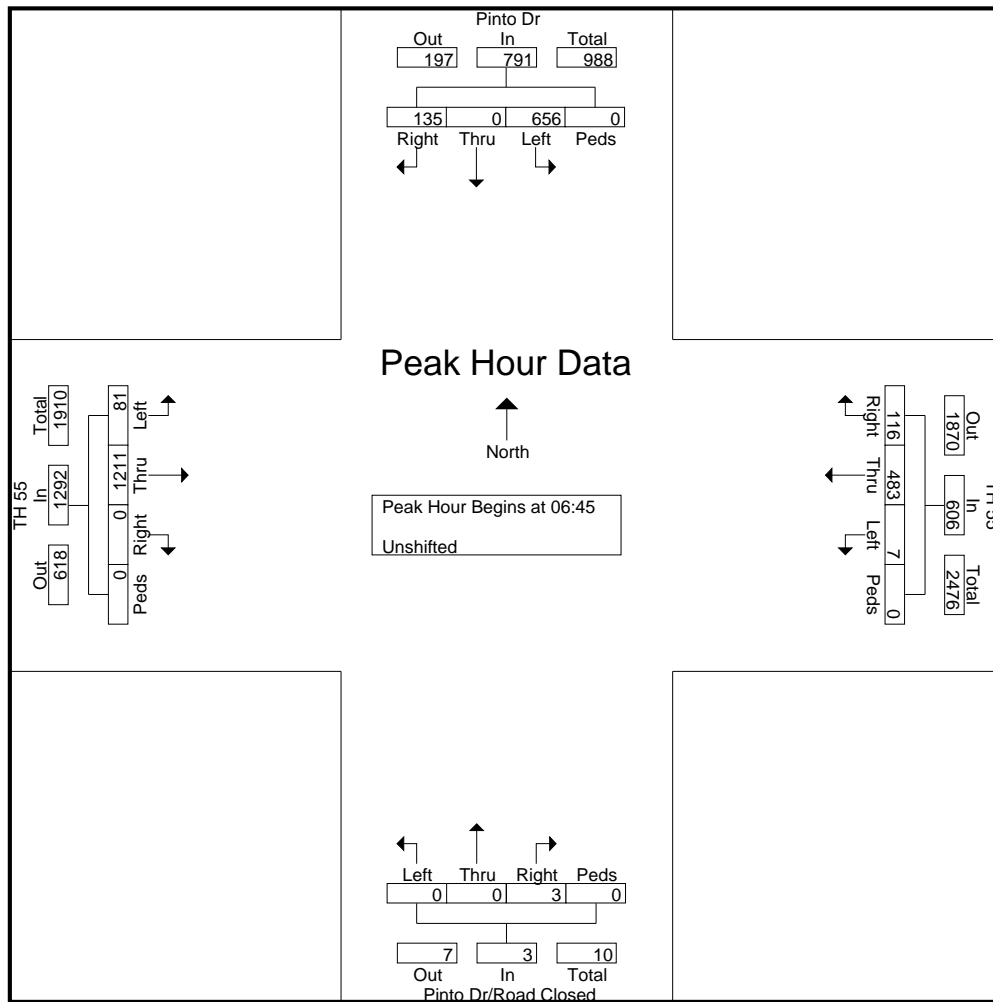



MINNESOTA DEPT OF TRANSPORTATION

TRAFFIC DATA COLLECTION - METRO

File Name : TH 55 @ PINTO DRIVE 2006
 Site Code : 07250219
 Start Date : 7/25/2006
 Page No : 4

Start Time	Pinto Dr Southbound					TH 55 Westbound					Pinto Dr/Road Closed Northbound					TH 55 Eastbound					Int. Total
	Left	Thru	Right	Peds	App. Total	Left	Thru	Right	Peds	App. Total	Left	Thru	Right	Peds	App. Total	Left	Thru	Right	Peds	App. Total	
12:00	65	0	28	0	93	3	106	67	0	176	0	0	0	0	0	20	140	0	0	160	429
12:15	69	0	20	0	89	3	108	55	0	166	0	0	0	0	0	29	144	1	0	174	429
12:30	61	0	40	0	101	6	121	54	0	181	0	0	0	0	0	18	147	2	0	167	449
12:45	70	0	22	0	92	5	129	78	0	212	1	0	1	0	2	20	116	0	0	136	442
Total Volume	265	0	110	0	375	17	464	254	0	735	1	0	1	0	2	87	547	3	0	637	1749
% App. Total	70.7	0	29.3	0		2.3	63.1	34.6	0		50	0	50	0		13.7	85.9	0.5	0		
PHF	.946	.000	.688	.000	.928	.708	.899	.814	.000	.867	.250	.000	.250	.000	.250	.750	.930	.375	.000	.915	.974

Peak Hour Analysis From 10:00 to 13:45 - Peak 1 of 1
 Peak Hour for Entire Intersection Begins at 12:00

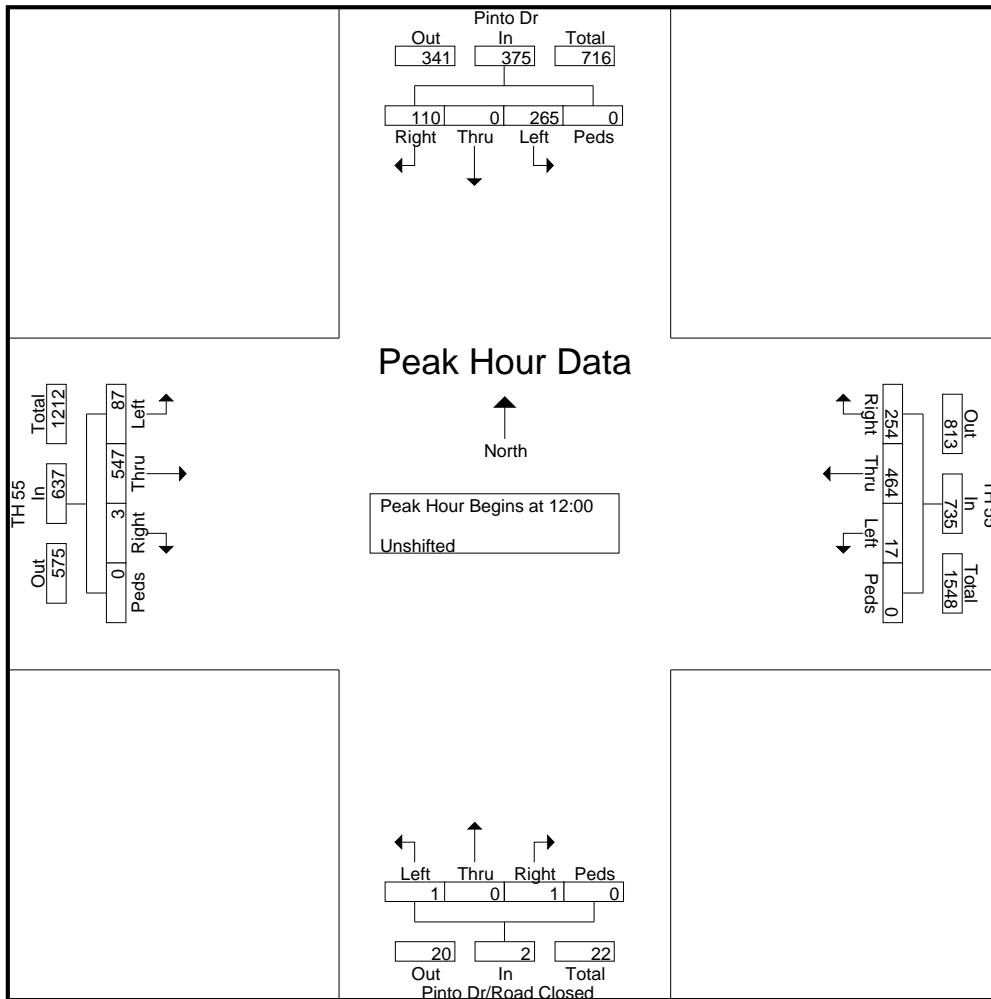



MINNESOTA DEPT OF TRANSPORTATION

TRAFFIC DATA COLLECTION - METRO

File Name : TH 55 @ PINTO DRIVE 2006
 Site Code : 07250219
 Start Date : 7/25/2006
 Page No : 5

Start Time	Pinto Dr Southbound					TH 55 Westbound					Pinto Dr/Road Closed Northbound					TH 55 Eastbound					Int. Total
	Left	Thru	Right	Peds	App. Total	Left	Thru	Right	Peds	App. Total	Left	Thru	Right	Peds	App. Total	Left	Thru	Right	Peds	App. Total	
16:30	61	0	25	0	86	4	276	141	0	421	0	0	0	0	0	39	153	0	0	192	699
16:45	54	0	24	0	78	1	286	163	0	450	3	0	0	0	3	27	130	0	0	157	688
17:00	70	0	24	0	94	2	323	151	0	476	0	0	0	0	0	46	135	1	0	182	752
17:15	45	0	34	0	79	3	303	160	0	466	0	0	0	0	0	34	142	1	0	177	722
Total Volume	230	0	107	0	337	10	1188	615	0	1813	3	0	0	0	3	146	560	2	0	708	2861
% App. Total	68.2	0	31.8	0		0.6	65.5	33.9	0		100	0	0	0		20.6	79.1	0.3	0		
PHF	.821	.000	.787	.000	.896	.625	.920	.943	.000	.952	.250	.000	.000	.000	.250	.793	.915	.500	.000	.922	.951

Peak Hour Analysis From 14:00 to 17:45 - Peak 1 of 1
 Peak Hour for Entire Intersection Begins at 16:30

