



MINNESOTA DEPT OF TRANSPORTATION

TRAFFIC DATA COLLECTION - METRO

TH-61 at I-694 , North Ramps
 Ref.Pt.: 143.536
 Data by: Alliant Inc.
 TURN MOVEMENT COUNT

File Name : TH-61 at I-694 N ramps 2008
 Site Code : 00000107
 Start Date : 9/17/2008
 Page No : 1

Groups Printed- Unshifted

Start Time	TH-61 Southbound				ramp from WB I-694 Westbound				TH-61 Northbound				ramp to WB I-694 Eastbound				Int. Total
	Left	Thru	Right	Peds	Left	Thru	Right	Peds	Left	Thru	Right	Peds	Left	Thru	Right	Peds	
06:00	0	98	61	0	8	0	19	0	25	43	0	0	0	0	0	0	254
06:15	0	130	106	0	18	0	31	0	38	83	0	0	0	0	0	0	406
06:30	0	262	96	0	24	0	51	0	69	46	0	0	0	0	0	0	548
06:45	0	300	65	0	37	0	84	0	83	93	0	0	0	0	0	0	662
Total	0	790	328	0	87	0	185	0	215	265	0	0	0	0	0	0	1870
07:00	0	323	98	1	38	0	43	0	90	81	0	0	0	0	0	0	674
07:15	0	402	82	0	36	0	34	0	93	130	0	0	0	0	0	0	777
07:30	0	387	78	0	41	0	44	0	97	127	0	0	0	0	0	0	774
07:45	0	381	54	0	46	0	66	0	102	82	0	0	0	0	0	0	731
Total	0	1493	312	1	161	0	187	0	382	420	0	0	0	0	0	0	2956
08:00	0	264	63	0	28	0	81	0	91	90	0	3	0	0	0	0	620
08:15	0	208	67	0	46	0	87	0	96	73	0	0	0	0	0	0	577
08:30	0	189	74	0	25	0	62	1	68	117	0	0	0	0	0	0	536
08:45	0	179	71	0	23	0	37	0	114	48	0	0	0	0	0	0	472
Total	0	840	275	0	122	0	267	1	369	328	0	3	0	0	0	0	2205
09:00	0	186	63	0	22	1	33	0	92	95	0	0	0	0	0	0	492
09:15	0	140	63	0	23	0	32	0	78	142	0	0	0	0	0	0	478
*** BREAK ***																	
Total	0	326	126	0	45	1	65	0	170	237	0	0	0	0	0	0	970
*** BREAK ***																	
10:30	0	176	58	0	21	0	12	0	89	133	0	0	0	0	0	1	490
10:45	0	138	79	0	14	0	26	0	69	164	0	0	0	0	0	0	490
Total	0	314	137	0	35	0	38	0	158	297	0	0	0	0	0	1	980
11:00	0	143	74	0	27	0	34	0	83	168	0	0	0	0	0	0	529
11:15	0	189	66	0	15	0	25	0	95	181	0	0	0	0	0	0	571
11:30	0	166	72	0	20	0	36	0	88	174	0	0	0	0	0	0	556
11:45	0	179	57	0	29	0	24	0	76	195	0	0	0	0	0	0	560
Total	0	677	269	0	91	0	119	0	342	718	0	0	0	0	0	0	2216
12:00	0	213	44	0	40	0	22	0	113	168	0	0	0	0	0	0	600
12:15	0	155	66	0	33	0	25	0	83	181	0	0	0	0	0	0	543
12:30	0	172	87	0	24	0	36	0	103	183	0	0	0	0	0	0	605
12:45	0	170	52	0	31	0	31	0	103	231	0	0	0	0	0	0	618
Total	0	710	249	0	128	0	114	0	402	763	0	0	0	0	0	0	2366
13:00	0	161	40	0	32	0	28	0	119	165	0	0	0	0	0	0	545
13:15	0	167	68	0	27	0	37	0	85	213	0	0	0	0	0	0	597
*** BREAK ***																	
Total	0	328	108	0	59	0	65	0	204	378	0	0	0	0	0	0	1142
*** BREAK ***																	
14:30	0	158	86	0	22	0	40	0	104	224	0	0	0	0	0	0	634
14:45	0	193	75	0	21	0	44	0	109	249	0	0	0	0	0	0	691
Total	0	351	161	0	43	0	84	0	213	473	0	0	0	0	0	0	1325
15:00	0	221	92	0	28	0	16	0	127	223	0	0	0	0	0	0	707
15:15	0	230	70	2	23	0	36	0	131	226	0	0	0	0	0	0	718
15:30	0	216	95	0	29	0	36	0	130	294	0	0	0	0	0	0	800
15:45	0	212	79	0	22	0	37	0	127	202	0	0	0	0	0	0	679
Total	0	879	336	2	102	0	125	0	515	945	0	0	0	0	0	0	2904



MINNESOTA DEPT OF TRANSPORTATION

TRAFFIC DATA COLLECTION - METRO

TH-61 at I-694 , North Ramps
 Ref.Pt.: 143.536
 Data by: Alliant Inc.
 TURN MOVEMENT COUNT

File Name : TH-61 at I-694 N ramps 2008
 Site Code : 00000107
 Start Date : 9/17/2008
 Page No : 3

Start Time	TH-61 Southbound					ramp from WB I-694 Westbound					TH-61 Northbound					ramp to WB I-694 Eastbound					Int. Total
	Left	Thru	Right	Peds	App. Total	Left	Thru	Right	Peds	App. Total	Left	Thru	Right	Peds	App. Total	Left	Thru	Right	Peds	App. Total	
Peak Hour Analysis From 06:00 to 09:15 - Peak 1 of 1																					
Peak Hour for Entire Intersection Begins at 07:00																					
07:00	0	323	98	1	422	38	0	43	0	81	90	81	0	0	171	0	0	0	0	0	674
07:15	0	402	82	0	484	36	0	34	0	70	93	130	0	0	223	0	0	0	0	0	777
07:30	0	387	78	0	465	41	0	44	0	85	97	127	0	0	224	0	0	0	0	0	774
07:45	0	381	54	0	435	46	0	66	0	112	102	82	0	0	184	0	0	0	0	0	731
Total Volume	0	1493	312	1	1806	161	0	187	0	348	382	420	0	0	802	0	0	0	0	0	2956
% App. Total	0	82.7	17.3	0.1		46.3	0	53.7	0		47.6	52.4	0	0		0	0	0	0		
PHF	.000	.928	.796	.250	.933	.875	.000	.708	.000	.777	.936	.808	.000	.000	.895	.000	.000	.000	.000	.000	.951

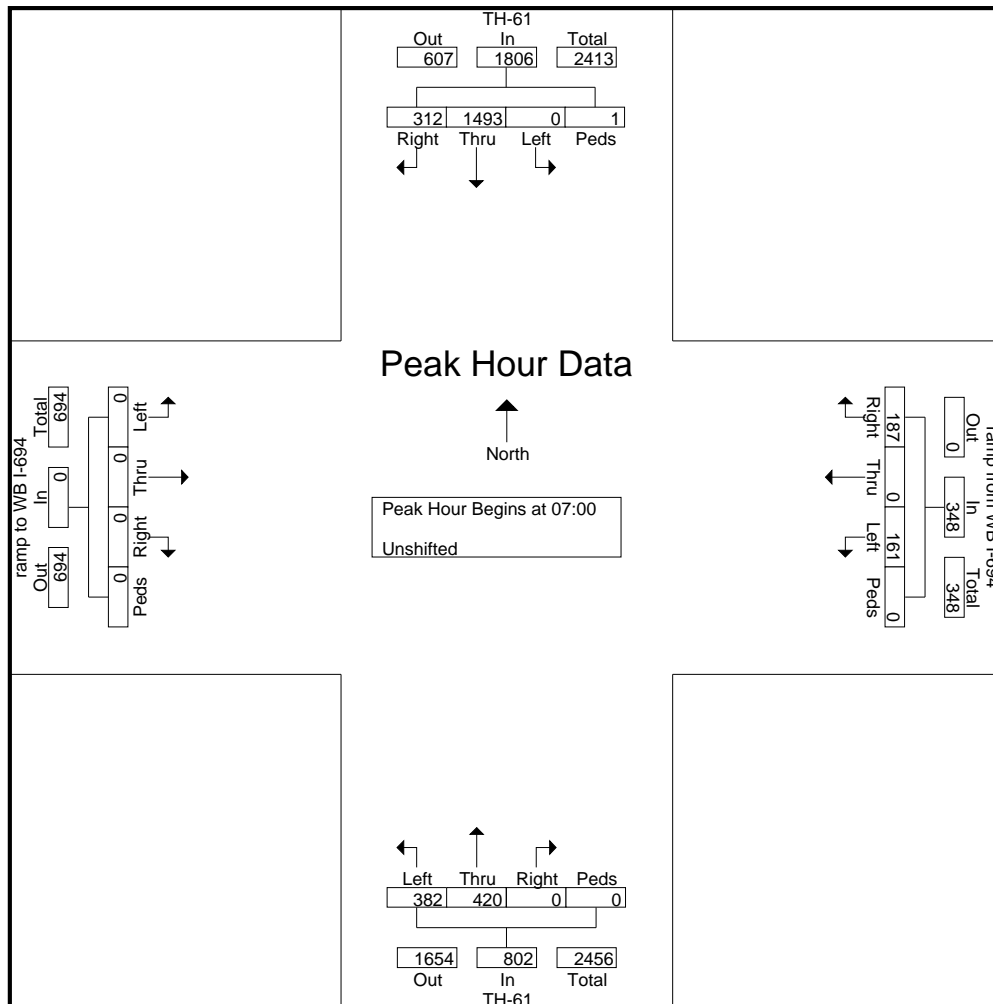



MINNESOTA DEPT OF TRANSPORTATION

TRAFFIC DATA COLLECTION - METRO

TH-61 at I-694 , North Ramps
 Ref.Pt.: 143.536
 Data by: Alliant Inc.
 TURN MOVEMENT COUNT

File Name : TH-61 at I-694 N ramps 2008
 Site Code : 00000107
 Start Date : 9/17/2008
 Page No : 4

Start Time	TH-61 Southbound					ramp from WB I-694 Westbound					TH-61 Northbound					ramp to WB I-694 Eastbound					Int. Total
	Left	Thru	Right	Peds	App. Total	Left	Thru	Right	Peds	App. Total	Left	Thru	Right	Peds	App. Total	Left	Thru	Right	Peds	App. Total	

Peak Hour Analysis From 14:30 to 17:45 - Peak 1 of 1

Peak Hour for Entire Intersection Begins at 16:30

16:30	0	279	75	0	354	27	0	38	0	65	115	317	0	0	432	0	0	0	0	0	851
16:45	0	239	69	0	308	24	0	47	0	71	111	351	0	0	462	0	0	0	0	0	841
17:00	0	228	92	0	320	26	0	51	0	77	119	322	0	0	441	0	0	0	0	0	838
17:15	0	225	65	1	291	33	0	71	0	104	107	372	0	0	479	0	0	0	0	0	874
Total Volume	0	971	301	1	1273	110	0	207	0	317	452	1362	0	0	1814	0	0	0	0	0	3404
% App. Total	0	76.3	23.6	0.1		34.7	0	65.3	0		24.9	75.1	0	0		0	0	0	0		
PHF	.000	.870	.818	.250	.899	.833	.000	.729	.000	.762	.950	.915	.000	.000	.947	.000	.000	.000	.000	.000	.974

