



MINNESOTA DEPT OF TRANSPORTATION

TRAFFIC DATA COLLECTION - METRO

TH-61 at Co.Rd. F (WBL)
 Ref.Pt.: 145.622
 Data by: Alliant Inc.
 TURN MOVEMENT COUNT

File Name : TH-61 at CoRd F 2008
 Site Code : 00000112
 Start Date : 9/11/2008
 Page No : 1

Groups Printed- Unshifted

Start Time	TH-61 Southbound				Co.Rd. F Westbound				TH-61 Northbound				Co.Rd. F Eastbound				Int. Total
	Left	Thru	Right	Peds	Left	Thru	Right	Peds	Left	Thru	Right	Peds	Left	Thru	Right	Peds	
06:00	7	99	0	1	15	13	1	0	7	29	2	0	0	7	4	0	185
06:15	8	203	0	2	16	13	5	0	12	31	9	0	0	12	5	0	316
06:30	7	253	2	1	26	20	6	0	9	42	5	0	0	20	9	0	400
06:45	22	282	4	0	23	35	16	0	6	62	9	0	0	29	15	0	503
Total	44	837	6	4	80	81	28	0	34	164	25	0	0	68	33	0	1404
07:00	25	323	0	0	36	22	13	0	7	67	12	0	0	48	16	0	569
07:15	35	393	2	0	28	29	15	0	2	71	14	0	2	50	25	0	666
07:30	21	305	4	0	27	18	14	0	4	60	10	0	0	32	17	0	512
07:45	19	261	1	0	14	42	12	0	11	69	13	0	0	27	16	0	485
Total	100	1282	7	0	105	111	54	0	24	267	49	0	2	157	74	0	2232
08:00	25	182	3	2	30	15	6	0	0	70	16	0	0	19	11	0	379
08:15	19	187	2	0	22	16	4	0	11	76	12	0	0	34	5	0	388
08:30	22	184	2	0	17	18	22	0	2	60	14	0	0	13	12	0	366
08:45	30	166	3	1	15	25	16	0	8	71	19	0	0	47	12	0	413
Total	96	719	10	3	84	74	48	0	21	277	61	0	0	113	40	0	1546
09:00	36	121	0	0	18	20	16	0	10	61	24	0	0	36	5	0	347
09:15	23	127	2	0	20	13	12	0	7	82	13	0	0	17	6	0	322
*** BREAK ***																	
Total	59	248	2	0	38	33	28	0	17	143	37	0	0	53	11	0	669
*** BREAK ***																	
10:30	17	124	0	0	17	12	5	0	9	105	11	0	1	13	4	0	318
10:45	15	137	1	0	12	14	11	0	10	98	17	0	0	16	9	0	340
Total	32	261	1	0	29	26	16	0	19	203	28	0	1	29	13	0	658
11:00	20	123	1	0	18	22	20	0	7	115	16	0	3	21	7	0	373
11:15	16	168	3	0	14	26	37	0	7	106	9	0	0	25	14	0	425
11:30	31	139	4	0	19	19	20	0	5	129	23	0	1	19	10	0	419
11:45	43	168	6	0	16	15	22	0	11	115	13	0	0	19	10	0	438
Total	110	598	14	0	67	82	99	0	30	465	61	0	4	84	41	0	1655
12:00	48	130	5	0	15	22	24	0	13	126	20	0	3	20	9	0	435
12:15	21	146	5	0	15	12	18	1	16	96	41	0	1	21	3	0	396
12:30	16	161	15	0	22	36	1	0	49	9	92	0	0	17	16	0	434
12:45	27	160	7	0	24	24	10	0	7	155	26	0	1	12	8	0	461
Total	112	597	32	0	76	94	53	1	85	386	179	0	5	70	36	0	1726
13:00	20	135	5	0	11	18	21	0	15	120	19	0	0	15	13	0	392
13:15	18	136	3	0	11	22	19	0	14	122	24	0	1	13	11	0	394
*** BREAK ***																	
Total	38	271	8	0	22	40	40	0	29	242	43	0	1	28	24	0	786
*** BREAK ***																	
14:30	27	135	6	1	19	19	18	0	19	165	25	1	0	14	9	0	458
14:45	22	113	2	0	21	36	32	0	19	206	41	0	0	36	7	0	535
Total	49	248	8	1	40	55	50	0	38	371	66	1	0	50	16	0	993
15:00	23	132	6	1	21	44	35	0	8	162	27	1	2	30	10	0	502
15:15	19	137	3	0	20	19	34	0	11	183	22	1	0	29	17	0	495
15:30	19	152	2	0	19	27	22	2	16	214	29	2	3	37	5	0	549
15:45	16	150	2	0	21	30	16	0	17	184	24	0	2	34	8	0	504
Total	77	571	13	1	81	120	107	2	52	743	102	4	7	130	40	0	2050



MINNESOTA DEPT OF TRANSPORTATION

TRAFFIC DATA COLLECTION - METRO

TH-61 at Co.Rd. F (WBL)
 Ref.Pt.: 145.622
 Data by: Alliant Inc.
 TURN MOVEMENT COUNT

File Name : TH-61 at CoRd F 2008
 Site Code : 00000112
 Start Date : 9/11/2008
 Page No : 2

Groups Printed- Unshifted

Start Time	TH-61 Southbound				Co.Rd. F Westbound				TH-61 Northbound				Co.Rd. F Eastbound				Int. Total
	Left	Thru	Right	Peds	Left	Thru	Right	Peds	Left	Thru	Right	Peds	Left	Thru	Right	Peds	
16:00	20	156	1	0	8	30	24	0	18	251	21	0	1	37	10	0	577
16:15	21	175	5	0	22	31	28	3	29	219	25	0	0	31	14	0	603
16:30	22	151	5	0	8	25	26	0	29	268	36	0	2	36	17	0	625
16:45	25	163	3	0	14	20	26	1	23	277	36	0	1	43	6	0	638
Total	88	645	14	0	52	106	104	4	99	1015	118	0	4	147	47	0	2443
17:00	22	163	4	0	15	41	22	0	24	281	30	0	2	36	22	0	662
17:15	20	157	1	0	5	41	37	0	27	258	42	0	4	35	13	0	640
17:30	14	130	4	0	6	31	27	0	17	219	27	4	1	43	5	0	528
17:45	20	133	3	1	13	43	21	0	18	183	34	0	1	42	9	0	521
Total	76	583	12	1	39	156	107	0	86	941	133	4	8	156	49	0	2351
Grand Total	881	6860	127	10	713	978	734	7	534	5217	902	9	32	1085	424	0	18513
Apprch %	11.2	87.1	1.6	0.1	29.3	40.2	30.2	0.3	8	78.3	13.5	0.1	2.1	70.4	27.5	0	
Total %	4.8	37.1	0.7	0.1	3.9	5.3	4	0	2.9	28.2	4.9	0	0.2	5.9	2.3	0	



MINNESOTA DEPT OF TRANSPORTATION

TRAFFIC DATA COLLECTION - METRO

TH-61 at Co.Rd. F (WBL)
 Ref.Pt.: 145.622
 Data by: Alliant Inc.
 TURN MOVEMENT COUNT

File Name : TH-61 at CoRd F 2008
 Site Code : 00000112
 Start Date : 9/11/2008
 Page No : 3

Start Time	TH-61 Southbound					Co.Rd. F Westbound					TH-61 Northbound					Co.Rd. F Eastbound					Int. Total
	Left	Thru	Right	Peds	App. Total	Left	Thru	Right	Peds	App. Total	Left	Thru	Right	Peds	App. Total	Left	Thru	Right	Peds	App. Total	
Peak Hour Analysis From 06:00 to 09:15 - Peak 1 of 1																					
Peak Hour for Entire Intersection Begins at 06:45																					
06:45	22	282	4	0	308	23	35	16	0	74	6	62	9	0	77	0	29	15	0	44	503
07:00	25	323	0	0	348	36	22	13	0	71	7	67	12	0	86	0	48	16	0	64	569
07:15	35	393	2	0	430	28	29	15	0	72	2	71	14	0	87	2	50	25	0	77	666
07:30	21	305	4	0	330	27	18	14	0	59	4	60	10	0	74	0	32	17	0	49	512
Total Volume	103	1303	10	0	1416	114	104	58	0	276	19	260	45	0	324	2	159	73	0	234	2250
% App. Total	7.3	92	0.7	0		41.3	37.7	21	0		5.9	80.2	13.9	0		0.9	67.9	31.2	0		
PHF	.736	.829	.625	.000	.823	.792	.743	.906	.000	.932	.679	.915	.804	.000	.931	.250	.795	.730	.000	.760	.845

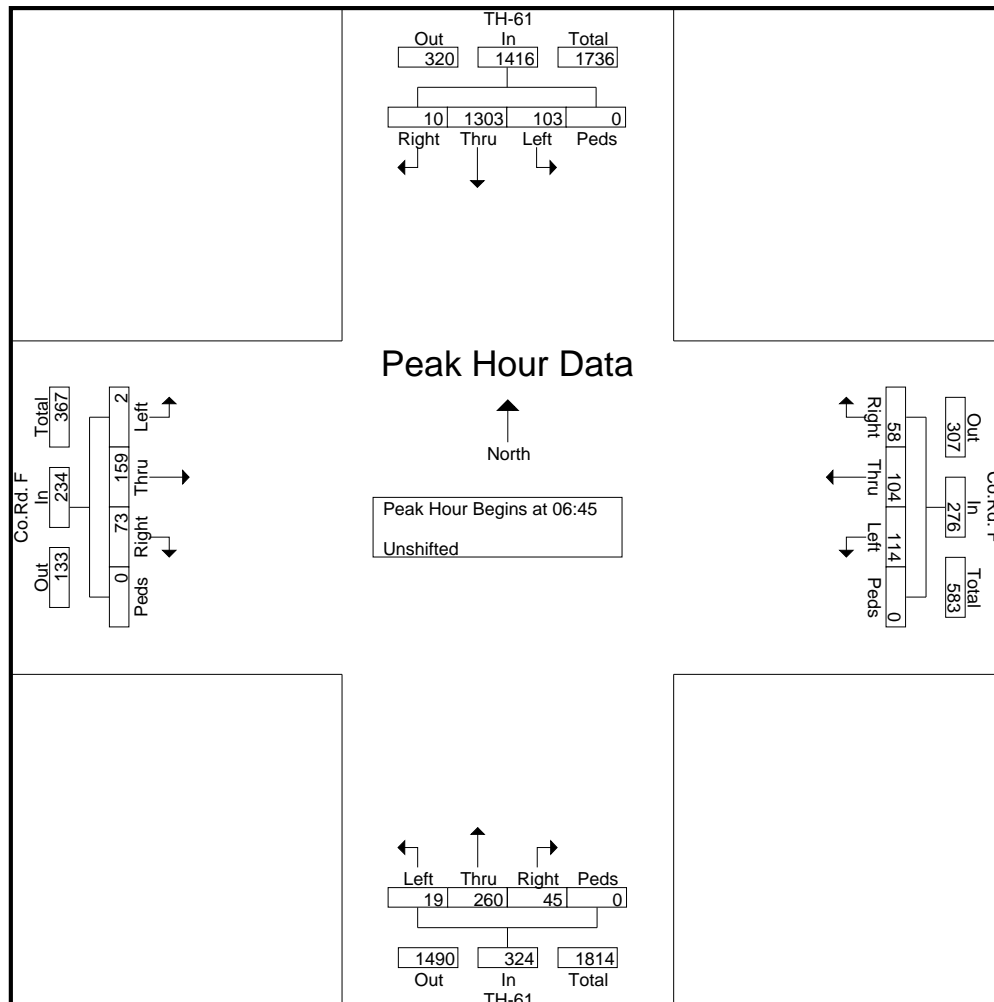



MINNESOTA DEPT OF TRANSPORTATION

TRAFFIC DATA COLLECTION - METRO

TH-61 at Co.Rd. F (WBL)
 Ref.Pt.: 145.622
 Data by: Alliant Inc.
 TURN MOVEMENT COUNT

File Name : TH-61 at CoRd F 2008
 Site Code : 00000112
 Start Date : 9/11/2008
 Page No : 4

Start Time	TH-61 Southbound					Co.Rd. F Westbound					TH-61 Northbound					Co.Rd. F Eastbound					Int. Total
	Left	Thru	Right	Peds	App. Total	Left	Thru	Right	Peds	App. Total	Left	Thru	Right	Peds	App. Total	Left	Thru	Right	Peds	App. Total	

Peak Hour Analysis From 14:30 to 17:45 - Peak 1 of 1
 Peak Hour for Entire Intersection Begins at 16:30

16:30	22	151	5	0	178	8	25	26	0	59	29	268	36	0	333	2	36	17	0	55	625
16:45	25	163	3	0	191	14	20	26	1	61	23	277	36	0	336	1	43	6	0	50	638
17:00	22	163	4	0	189	15	41	22	0	78	24	281	30	0	335	2	36	22	0	60	662
17:15	20	157	1	0	178	5	41	37	0	83	27	258	42	0	327	4	35	13	0	52	640
Total Volume	89	634	13	0	736	42	127	111	1	281	103	1084	144	0	1331	9	150	58	0	217	2565
% App. Total	12.1	86.1	1.8	0		14.9	45.2	39.5	0.4		7.7	81.4	10.8	0		4.1	69.1	26.7	0		
PHF	.890	.972	.650	.000	.963	.700	.774	.750	.250	.846	.888	.964	.857	.000	.990	.563	.872	.659	.000	.904	.969

